

HB工业齿轮箱 HB reducer

选型指南

001-009

选型参数表

010-031

外形安装尺寸

032-066 附件067-071

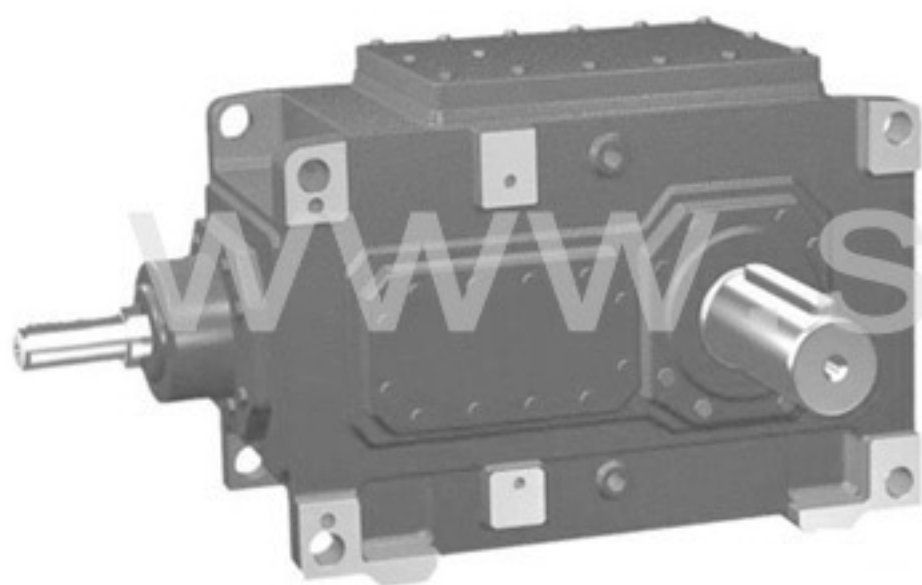

H、B 系列工业齿轮箱概述

- H、B 齿轮箱采用通用设计方案，可按客户需求变型为行业专用的齿轮箱。
- 实现平行轴、直交轴、立式、卧式通用箱体，零部件种类减少，规格型号增加。
- 采用吸音箱体结构、较大的箱体表面积和大风扇、圆柱齿轮和螺旋锥齿轮均采用先进的磨齿工艺，使整机的温升、噪声降低、动转的可靠性得到提高，传递功率增大。
- 输入方式：电机联接法兰、轴输入。
- 输出方式：带平键的实心轴、带平键的空心轴、胀紧盘联结的空心轴、花键联结的空心轴、花键联结的实心轴和法兰联结的实心轴。
- 安装方式：卧式、立式、摆动底座式、扭力臂式。
- H、B 系列产品有 3~26 型规格，减速传动级数有 1~4 级，速比 1.25~450，和 R、K 系列组合得到更大的速比。

H、B series gear units overview:

- H.B series gear units adopt currency layout and may transform into speeral reducer according to customer's requirement.
- The housing of one size can realize parallel shaft, right-angle shaft modes and horizontal, vertical mounting modes. Variety of components is reducible, the number of reducer's mode is augmentable.
- Sound-absorbable structure, lager surface, big fan reduce temperature and noise, advanced grinding process of cylindrical gear and bevel gear improve stability and transmit power more efficeintly.
- Input mode: motor connected flange, shaft input.
- Output mode: solid shaft with flat key, hollow shaft with flat key, hollow shaft with shrink disk, hollow or solid shaft with involute splines, solid shaft with flange.
- Mounting mode: Foot-mounted, flange-mounted, swing base-mounted, torque-arm-mounted.
- H.B series include sizes 3~26, number of stages is 1~4, ratio is 1.25~450, combining with R series and K series, ratio will be higher.

H、B 系列结构图:

H.B series reducer structure drawing:

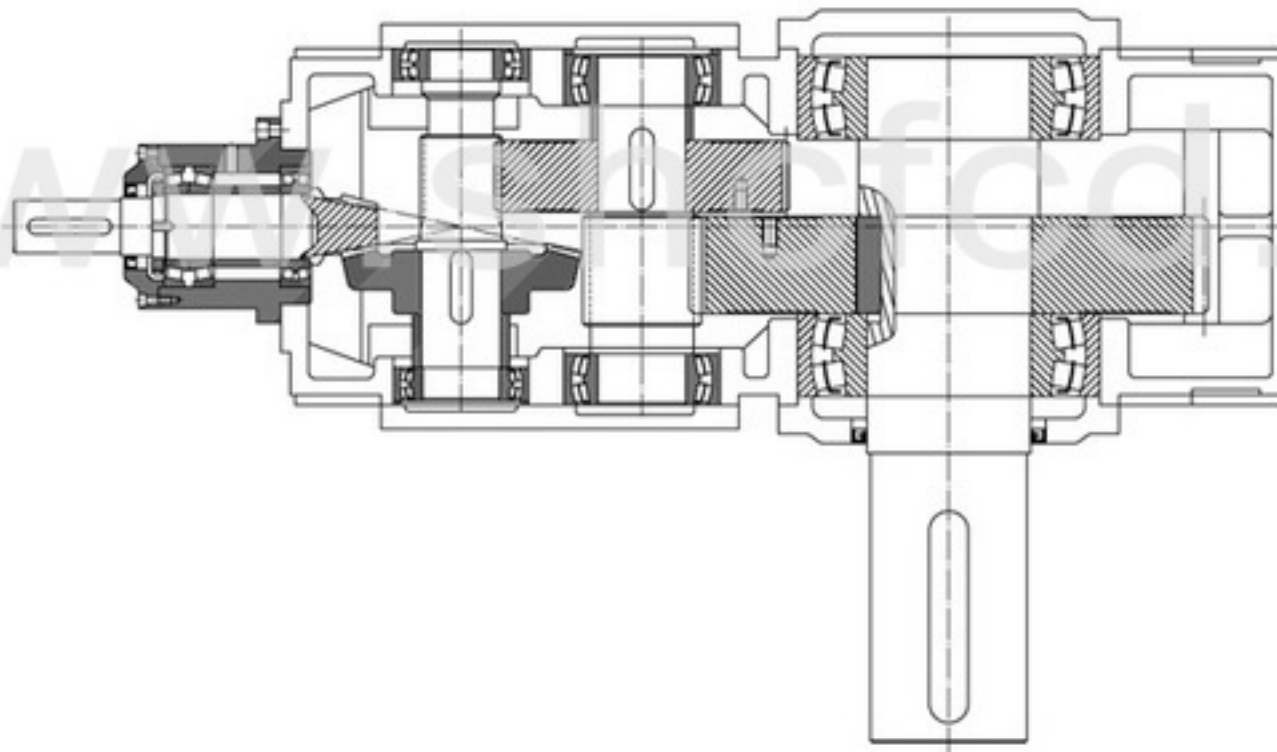

H、B 系列型号规格表示方法举例:

H.B series model expressing example:

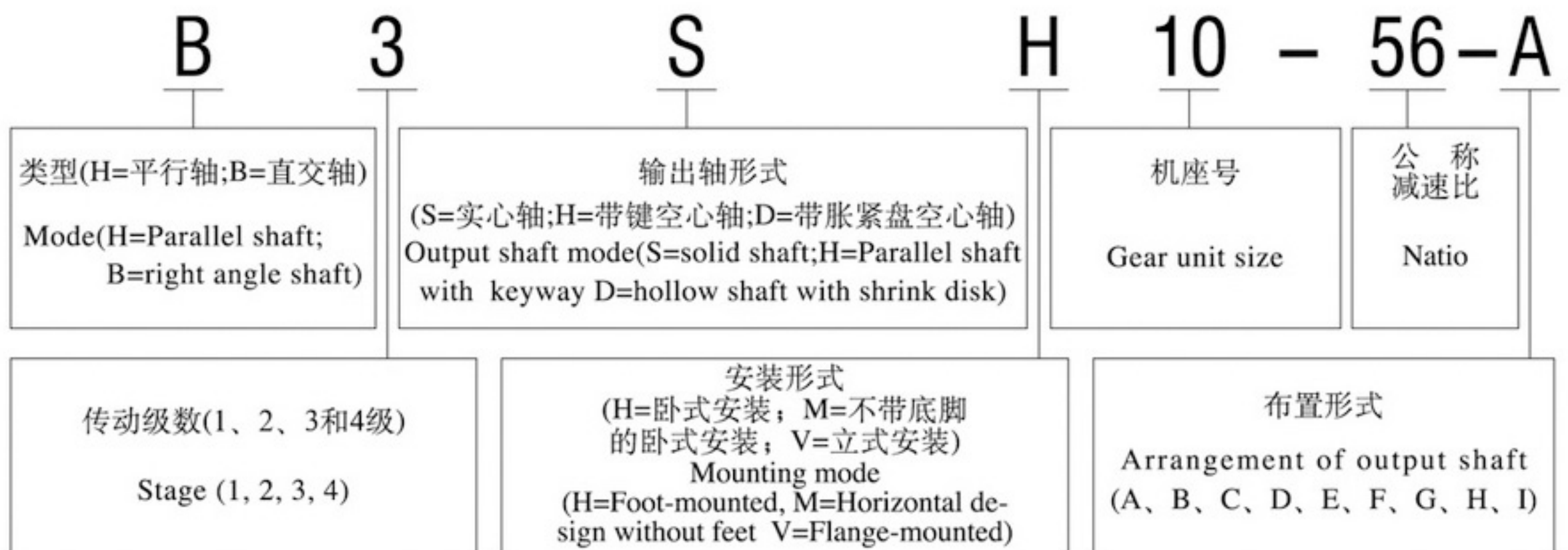

符号说明:

ED=每小时工作周期,以百分比表示,如ED=60%/h

f1=被驱动设备系数(表1)

f2=原动机系数

f3=峰值扭矩系数

f4、f5=环境温度系数(表2、3)

f6、f7=海拔高度系数(表4、5)

f8=齿轮箱供油系数(表6)

f9、f10、f11、f12=热容量系数(表7、8、9、10)

a1=型号系数(表11)

a2=速比系数(表12)

P1=输入功率

PG1=不带辅助冷却装置的齿轮箱热容量

PG2=带冷却风扇装置的齿轮箱热容量

PG3=带内置式冷却盘管的齿轮箱热容量

PG4=带内置式冷却盘管和风扇的齿轮箱热容量

Symbol description:

ED=operating cycle per hour, express as percent, for example ED=60%/h

f1=Factor for driven machine (table 1)

f2=Factor for prime mover

f3=Peak torque factor

f4,f5=Ambient temperature factor (table 2,3)

f6,f7=Altitude factor (table 4,5)

f8=Applying oil factor of gear box (table 6)

f9,f10,f11,f12=Thermal capacity factor (table 7,8,9,10)

a1=Size factor (table 11)

a2=Transmission ratio factor (table 12)

P1=Power rating of driven machine

PG1=Thermal capacity for gear units without auxiliary cooling,

PG2=Thermal capacity for gear units with fan cooling,

PG3=Thermal capacity for gear units with built-in cooling coil

PG4=Thermal capacity for gear units with built-in cooling coil and fan

HB系列选型及举例:

HB series type selection example:

序号 Steps	说明 Specification	代号 Symbol	参数计算 Calculate parameter						
1	被驱动设备系数 Driven machine factor	f1	查P212页f1表 See P212 f1 table						
2	原动机系数 Factor for prime mover	f2	原动机系数 Factor for prime mover		f ₂				
			电机、液压马达、汽轮机 Electric motors, hydraulic motors, turbines		1.0				
			4-6缸活塞发动机, 周期变化1: 100至1: 200 Piston engines 4 - 6 cylinders cyclic variation 1 : 100 to 1 : 200		1.25				
			1-3缸活塞发动机, 周期变化1: 100 Piston engines 1 - 3 cylinders cyclic variation up to 1 : 100		1.5				
3	齿轮箱许用输入转速 Permissible input speed	n1	≤ 1500						
4	输入与输出轴关系 Position of input and output	H、B	平行选H系列, 垂直选B系列 H:Parallel shaft, B: Right-angled shaft.						
5	确定减速比 Determine ration	i	i=n1/n2						
6	齿轮箱传动效率 Efficiency	η	单级single stage:98%, 二级2-stage:96%, 三级3-stage:94%, 四级4-stage:92%						
7	以被驱动设备所需的扭矩或功率, 确认齿轮箱输入功率 Determine input power	P1	P1=T2 · n1/(9550 · i · η) 或 P1=P2/η						
8	根据计算, 查传动能力表, 确定齿轮箱规格 By calculation, determine type in reference to transmission table	T2N、P1N	T2N ≥ T2 · f1 · f2 或 (or) P1N ≥ P1 · f1 · f2 如果不满足条件: 3.33 · P1 > P1N, 请向我们咨询。 If not meet: 3.33 · P1 > P1N please consult us.						
9	确认输出形式 Determine output mode		输出轴形式及安装方位 Output mode & mounting position						
10	峰值扭矩校核* Check for maximum torque	TA	P _{IN} ≥ TA · n1 · f3/9550	f3	每小时峰值负荷次数 Load peaks per hour				
						1-5	6-30	31-100	> 100
					单向载荷 Steady direction of load	0.5	0.65	0.7	0.85
交替载荷 Alternating direction of load	0.7	0.95	1.10	1.25					
11	选定连接安装和附件后、校核轴许用强度 Verify intensity of shaft	Fr、Fa	见第215页 See P215						
12	确认润滑方式、选择润滑油(见附录) Determine lubrication method and lubrication oil(see attachment)		卧式安装 Horizontal		立式安装 Vertical				
			所有需要润滑的零部件均浸在润滑油中, 或采用飞溅润滑方式, 也可按用户要求提供强制润滑方式。 Immersion, splash, forced lubrication.		可选润滑油供给方式: A. 浸油润滑 B. 通过法兰联接泵或电动泵进行强制润滑。 根据n1值确定 (P272) A: immersion B: Pump-forced lubrication				
13	确认冷却方式 Cooling method		1 如满足以下条件, 则齿轮箱不带辅助冷却装置 Adequate for gear units without auxiliary cooling, if: P1 ≤ PG1 × f4 × f6 × f8 × f9 2 如满足以下条件, 则齿轮箱带冷却风扇可满足要求, Adequate for gear units with fan cooling, if: P1 ≤ PG2 × f4 × f6 × f8 × f10 3 如满足以下条件, 则齿轮箱需带冷却盘管可满足要求, Adequate for gear units with fitted cooling coil, if: P1 ≤ PG3 × f5 × f7 × f8 × f11 4 如满足以下条件, 则齿轮箱需带冷却盘管和风扇可满足要求, Adequate for gear units with cooling coil and fan, if: P1 ≤ PG4 × f5 × f7 × f8 × f12 5 如需要较高的热容量, 则可按用户要求提供外部润滑油冷却装置进行冷却。 For higher thermal capacities, cooling by external oil cooler on request.: (f4、f5、f6、f7、f8、f9、f10、f11、f12 查refer to P213,214)						

* 峰值扭矩: 最大负载扭矩, 是指启动、制动或最大脉动载荷所引起的最大扭矩。(一般工况条件下峰值扭矩为启动或制动时的最大扭矩)
* Peak torque: Maximum torque is maximum starting torque, maximum braking torque.

选型举例
Selection example

已知条件:

原动机:

$P_m=75\text{KW}$
 $n_1=1500\text{rpm}$
 $T_A=720\text{N}\cdot\text{m}$

工作机(皮带输送机):

$P_2=66\text{KW}$
 $n_2=26\text{rpm}$
工作制为=12小时/天
每小时起动次数: 10次
每小时工作周期ED=100%
环境温度: 30℃
室外安装
海拔高度: 500m
直交齿轮箱
安装方式: 卧式
布置方式: C

选型步骤:

1. 计算速比:

$$i=n_1/n_2=1500/26=57.7 \quad i_N=56$$

2. 确定减速机的额定功率:

$$P_{1N} > P_1 \cdot f_1 \cdot f_2 = P_2 \cdot f_1 \cdot f_2 / \eta$$

$$= 66 \times 1.3 \times 1 / 0.94 = 91.3\text{kW}$$

根据传动能力表可选B3, 9型, P_{1N} 为96kW

校核: $3.33 \times P_1 > P_{1N}$

$$3.33 \times P_1 = 3.33 \times P_2 / \eta = 3.33 \times 66 / 0.94$$

$$= 233.8 \text{ kW} > P_{1N} \quad \text{满足要求。}$$

3. 校核峰值扭矩:

$$P_{1N} > T_A \cdot n_1 \cdot f_3 / 9550$$

$$= 720 \times 1500 \times 0.65 / 9550 = 73.5\text{kW}$$

$$P_{1N} = 96\text{kW} > 73.5\text{kW} \quad \text{符合条件}$$

4. 校核热容量:

$$P_{G1} \times f_4 \times f_6 \times f_8 \times f_9$$

$$= 70.7\text{kW} \times 0.88 \times 1 \times 1 \times (1.23 - 2.80 \times 0.085 \times 0.15)$$

$$= 74.3\text{kW}$$

$$P_1 = P_2 / \eta = 66\text{kW} / 0.94 = 70.2 < 74.3\text{kW}$$

所以齿轮箱不带辅助冷却装置。

型号表示为: B3SH9-56-C

Given condition:

Driving machine:

$P_m=75\text{KW}$
 $n_1=1500\text{rpm}$
 $T_A=720\text{N}\cdot\text{m}$

Driven machine(belt conveyor):

$P_2=66\text{KW}$
 $n_2=26\text{rpm}$
service duration: 12h/day
Start-up: 10times/hour
Working circle ED=100% per hour
Ambient temperature: 30℃
installed in open field
Altitude: 500m
Right-angled shaft
Mounting mode: Horizontal
Shaft amangement: C

Selecting steps:

1. Calculate ratio:

$$i=n_1/n_2=1500/26=57.7 \quad i_N=56$$

2. Determine nominal power:

$$P_{1N} > P_1 \cdot f_1 \cdot f_2 = P_2 \cdot f_1 \cdot f_2 / \eta$$

$$= 66 \times 1.3 \times 1 / 0.94 = 91.3\text{kW}$$

Choose B3, size: 9, P_{1N} : 96kW

Verify: $3.33 \times P_1 > P_{1N}$

$$3.33 \times P_1 = 3.33 \times P_2 / \eta = 3.33 \times 66 / 0.94$$

$$= 233.8 \text{ kW} > P_{1N}$$

3. Verify peak torque:

$$P_{1N} > T_A \cdot n_1 \cdot f_3 / 9550$$

$$= 720 \times 1500 \times 0.65 / 9550 = 73.5\text{kW}$$

$$P_{1N} = 96\text{kW} > 73.5\text{kW} \quad \text{Meet requirement.}$$

4. Verify thermal capacity:

$$P_{G1} \times f_4 \times f_6 \times f_8 \times f_9$$

$$= 70.7\text{kW} \times 0.88 \times 1 \times 1 \times (1.23 - 2.80 \times 0.085 \times 0.15)$$

$$= 74.3\text{kW}$$

$$P_1 = P_2 / \eta = 66\text{kW} / 0.94 = 70.2 < 74.3\text{kW}$$

So auxiliary cooling devece is unnecessary.

TYPE: B3SH9-56-C

服务系数

Service Factors

表1 Table 1		工作机系数 Factor for driven machine					f1		
工作机 Driven machines		日带载运行时间 (小时) Effective daily operating period under load in hours			工作机 Driven machines		日带载运行时间 (小时) Effective daily operating period under load in hours		
		0.5	>0.5-10	>10			0.5	>0.5-10	>10
污水处理 Waste water treatment					输送机械 Conveyors				
浓缩器 (中心传动) Thickeners (central drive)		-	-	1.2	斗式输送机 Bucket conveyors	-	1.4	1.5	
压滤器 Filter presses		1.0	1.3	1.5	绞车 Hauling winches	1.4	1.6	1.6	
絮凝器 Flocculation apparata		0.8	1.0	1.3	卷扬机 Hoists	-	1.5	1.8	
曝气机 Aerators		-	1.8	2.0	皮带输送机 ≤150kW Belt conveyors 150 kW	1.0	1.2	1.3	
接集设备 Raking equipment		1.0	1.2	1.3	皮带输送机 >150kW Belt conveyors 150 kW	1.1	1.3	1.4	
纵向、回转组 Combined longitudinal and rotary rakes		1.0	1.3	1.5	货用电梯 * Goods lifts	-	1.2	1.5	
合式接集装置 Pre-thickeners		-	1.1	1.3	客用电梯 * Passenger lifts	-	1.5	1.8	
浓缩器 Screw pumps		-	1.3	1.5	刮板式输送机 Apron conveyors	-	1.2	1.5	
螺杆泵 Screw pumps		-	1.3	1.5	自动扶梯 Escalators	1.0	1.2	1.4	
水轮机 Water turbines		-	-	2.0	轨道行走机构 Rail travelling gears	-	1.5	-	
泵 Pumps					变频装置 Frequency converters	-	1.8	2.0	
离心泵 Centrifugal pumps		1.0	1.2	1.3	往复式压缩机 Reciprocating compressors	-	1.8	2.0	
容积式泵 Positive-displacement pumps					起重机械 ** Cranes				
1个活塞 1 piston		1.3	1.4	1.8	回转机构 * Slewing gears	1.0	1.4	1.8	
>1个活塞 > 1piston		1.2	1.4	1.5	俯仰机构 Luffing gears	1.0	1.1	1.4	
挖泥机 Dredgers					行走机构 Travelling gears	1.1	1.6	2.0	
斗式输送机 Bucket conveyors		-	1.6	1.6	提升机构 Hoisting gears	1.0	1.1	1.4	
倾卸装置 Dumping devices		-	1.3	1.5	转臂式起重机 Derricking jib cranes	1.0	1.2	1.6	
Carterpillar行走机构 Carterpillar travelling gears		1.2	1.6	1.8	冷却塔 Cooling towers				
斗式挖掘机 Bucket wheel excavators					冷却塔风扇 Cooling tower fans	-	-	2.0	
用于捡拾 as pick-up		-	1.7	1.7	风机 (轴流和离心式) Blowers (axial and radial)	-	1.4	1.5	
用于粗料 for primitive material		-	2.2	2.2	食品工业 Food industry				
切碎机 Cutter heads		-	2.2	2.2	蔗糖生产 Cane sugar production				
行走机构 * Traversing gears		-	1.4	1.8	甘蔗切碎机 * Cane knives	-	-	1.7	
弯板机 Plate bending machines		-	1.0	1.0	甘蔗碾磨机 Cane mills	-	-	1.7	
化学工业 Chemical industry					甜菜糖生产 Beet sugar production				
挤压机 Extruders		-	-	1.6	甜菜绞碎机 Beet cossettes macerators,	-	-	1.2	
调浆机 Dough mills		-	1.8	1.8	榨取机, 机械致 Extraction plants, Mechanical	-	-	1.4	
橡胶研光机 Rubber calenders		-	1.5	1.5	冷机、蒸煮机 Refrigerators, Juice boilers,	-	-	1.4	
冷却圆筒 Cooling drums		-	1.3	1.4	甜菜清洗机 Sugar beet washing machines,	-	-	1.5	
混料机, 用于 Mixers for					甜菜切碎机 Sugar beet cutters	-	-	1.5	
均匀介质 uniform media		1.0	1.3	1.4	造纸机械 Paper machines				
非均匀介质 non-uniform media		1.4	1.6	1.7	各种类型 *** of all-kind	-	1.8	2.0	
搅拌机, 用于 Agitators for media with					碎浆机驱动装置 Pulper drives	根据客户要求供货 On request			
密度均匀介质 uniform density		1.0	1.3	1.5	离心式压缩机 Centrifugal compressors	-	1.4	1.5	
不均匀介质 non-uniform density		1.2	1.4	1.6	索道缆车 Cableways				
不均匀气体吸收 non-uniform gas absorption		1.4	1.6	1.8	运货索道 Material ropeways	-	1.3	1.4	
烘炉 Toasters		1.0	1.3	1.5	往返系统空中索道 To- and fro system aerial ropeways	-	1.6	1.8	
离心机 Centrifuges		1.0	1.2	1.3	T型杆升降机 T-bar lifts	-	1.3	1.4	
金属加工设备 Metal working mills					连续索道 Continuous ropeways	-	1.4	1.6	
翻板机 Plate tilters		1.0	1.0	1.2	水泥工业 Cement industry				
推钢机 Ingot pushers		1.0	1.2	1.2	混凝土搅拌机 Concrete mixers	-	1.5	1.5	
绕线机 Winding machines		-	1.6	1.6	破碎机 * Breakers	-	1.2	1.4	
冷床横移架 Cooling bed transfer frames		-	1.5	1.5	回转窑 Rotary kilns	-	-	2.0	
辊式矫直机 Roller straighteners		-	1.6	1.6	管式磨机 Tube mills	-	-	2.0	
辊道 Roller tables					选粉机 Separators	-	1.6	1.6	
连续式 continuous		-	1.5	1.5	辊压机 Roll crushers	-	-	2.0	
间歇式 intermittent		-	2.0	2.0					
可逆式轧管机 Reversing tube mills		-	1.8	1.8					
剪切机 Shears									
连续式 * continuous		-	1.5	1.5					
曲柄式 * crank type		1.0	1.0	1.0					
连铸机驱动装置 Continuous casting drivers		-	1.4	1.4					
轧机 Rolls									
可逆式开坯机 Reversing blooming mills		-	2.5	2.5					
可逆式板坯轧机 Reversing slabbing mills		-	2.5	2.5					
可逆式线材轧机 Reversing wire mills		-	1.8	1.8					
可逆式薄板轧机 Reversing sheet mills		-	2.0	2.0					
可逆式中厚板轧机 Reversing plate mills		-	1.8	1.8					
辊缝调节驱动装置 Roll adjustment drives		0.9	1.0	-					

1. 工作机额定功率P2的确定:

- * 按最大的扭矩确定额定功率。
- ** 可交载荷准确地分类。
- *** 检验热容量是绝对必要的。

2. 所列各项系数均为经验值。使用这些系数的前提条件是, 所述机械设备应符合通常的设计规范和载荷条件。如遇特殊情况, 请及时与我们联系。

3. 对于那些未列入此表的工作机械, 请与我们联系。

1. Design for power rating of driven machine P2

- *) Designed power corresponding to max. torque
- ***) Load can be exactly classified, for Instance.
- ***) A check for thermal capacity is absolutely essential

2. The listed factors are empirical values. Prerequisite for their application is that the machinery and equipment mentioned correspond to generally accepted design and load specifications. In case of deviations from standard conditions, please refer to us

3. For driven machines which are not listed in this table, please refer to us.

不带辅助冷却装置或仅带冷却风扇 Without auxiliary cooling or with fan cooling					
环境温度 Ambient temperature	每小时工作周期 (ED) 百分比% Operating cycle per hour (ED) in %				
	100	80	60	40	20
10 °C	1.11	1.31	1.60	2.14	3.64
20 °C	1.00	1.18	1.44	1.93	3.28
30 °C	0.88	1.04	1.27	1.70	2.89
40 °C	0.75	0.89	1.08	1.45	2.46
50 °C	0.63	0.74	0.91	1.22	2.07

带冷却盘管或带冷却盘管和风扇 For cooling with cooling coil, or with fan and cooling coil					
环境温度 Ambient temperature	每小时工作周期 (ED) 百分比% Operating cycle per hour (ED) in %				
	100	80	60	40	20
10 °C	1.05	1.23	1.50	2.03	3.41
20 °C	1.00	1.17	1.43	1.93	3.25
30 °C	0.93	1.09	1.33	1.79	3.02
40 °C	0.87	1.02	1.24	1.68	2.83
50 °C	0.81	0.95	1.16	1.56	2.63

不带辅助冷却装置或仅带冷却风扇 Without auxiliary cooling or with fan cooling					
系数 Factor	海拔高度 (m, 高于海平面) Altitude (metres above MSL)				
	up to 1000	up to 2000	up to 3000	up to 4000	up to 5000
f6	1.0	0.95	0.90	0.85	0.80

带冷却盘管或带冷却盘管和风扇 For cooling with cooling coil, or with fan and cooling coil					
系数 Factor	海拔高度 (m, 高于海平面) Altitude (metres above MSL)				
	up to 1000	up to 2000	up to 3000	up to 4000	up to 5000
f7	1.0	0.98	0.96	0.94	0.92

齿轮箱类型 Gear unit type	供油方式 Oil supply	Sizes 4 ... 12				Sizes 13 ... 18			
		不带辅助冷却装置 Without auxiliary cooling	带冷却风扇 With fan	带冷却盘管 With cooling coil	带风扇和冷却盘管 With fan and cooling coil	不带辅助冷却装置 Without auxiliary cooling	带冷却风扇 With fan	带冷却盘管 With cooling coil	带风扇和冷却盘管 With fan and cooling coil
H2.V, H3.V H4.V	浸油润滑 Dip lubrication	0.95	*	0.95	*	*	*	*	*
	强制润滑 Forced lubrication	1.15	*	1.05	*	1.15	*	1.05	*
B2.V, B3.V B4.V	浸油润滑 Dip lubrication	0.95	0.95	0.95	0.95	*	*	*	*
	强制润滑 Forced lubrication	1.15	1.10	1.10	1.10	1.15	1.10	1.10	1.10

类型 Gear unit type	n 1/min	安装空间 Place of installation		
		狭小空间安装 风速 > 0.5 m/s Small confined spaces Wind velocity > 0.5 m/s	大厅或大车间安装 风速 > 1.4 m/s Large halls, workshops Wind velocity > 1.4 m/s	室外安装 风速 > 4.0 m/s In the open Wind velocity > 4.0 m/s
H1	750	0.68 - 0.26 x a1 x a2	0.79 - 0.27 x a1 x a2	1.00
	1000	0.70 - 0.79 x a1 x a2	0.84 - 0.85 x a1 x a2	1.14 - 0.81 x a1 x a2
	1500	0.72 - 2.50 x a1 x a2	0.89 - 2.60 x a1 x a2	1.25 - 2.60 x a1 x a2
H2	750	0.70 - 0.08 x a1 x a2	0.79 - 0.21 x a1 x a2	1.00
	1000	0.76 - 1.00 x a1 x a2	0.87 - 1.40 x a1 x a2	1.12 - 1.30 x a1 x a2
	1500	0.83 - 4.10 x a1 x a2	0.96 - 4.60 x a1 x a2	1.25 - 4.20 x a1 x a2
H3	750	0.76	0.81 - 0.06 x a1 x a2	1.00
	1000	0.83 - 1.20 x a1 x a2	0.90 - 1.36 x a1 x a2	1.11 - 1.30 x a1 x a2
	1500	0.93 - 4.70 x a1 x a2	1.00 - 4.80 x a1 x a2	1.27 - 5.10 x a1 x a2
H4	750	0.78	0.83	1.00
	1000	0.85	0.91 - 1.60 x a1 x a2	1.10 - 2.40 x a1 x a2
	1500	0.97 - 10.0 x a1 x a2	1.03 - 12.5 x a1 x a2	1.27 - 14.0 x a1 x a2
B2	750	0.66 - 0.09 x a1 x a2	0.77 - 0.14 x a1 x a2	1.00
	1000	0.69 - 0.70 x a1 x a2	0.81 - 0.77 x a1 x a2	1.08 - 0.64 x a1 x a2
	1500	0.74 - 3.20 x a1 x a2	0.88 - 3.30 x a1 x a2	1.20 - 2.90 x a1 x a2
B3	750	0.73	0.80 - 0.05 x a1 x a2	1.00
	1000	0.79 - 0.63 x a1 x a2	0.87 - 0.81 x a1 x a2	1.10 - 0.73 x a1 x a2
	1500	0.86 - 2.40 x a1 x a2	0.95 - 2.60 x a1 x a2	1.23 - 2.80 x a1 x a2
B4	750	0.77	0.82	1.00
	1000	0.83	0.88	1.09 - 0.29 x a1 x a2
	1500	0.92 - 1.70 x a1 x a2	0.99 - 2.20 x a1 x a2	1.24 - 2.60 x a1 x a2

类型 Gear unit type	n 1/min	安装空间 Place of installation		
		狭小空间安装 风速 > 0.5 m/s Small confined spaces Wind velocity > 0.5 m/s	大厅或大车间安装 风速 > 1.4 m/s Large halls, workshops Wind velocity > 1.4 m/s	室外安装 风速 > 4.0 m/s In the open Wind velocity > 4.0 m/s
H1	750	0.97 - 0.05 x a1 x a2	0.97 - 0.04 x a1 x a2	1.00
	1000	1.18 - 0.33 x a1 x a2	1.20 - 0.33 x a1 x a2	1.23 - 0.32 x a1 x a2
	1500	1.53 - 1.00 x a1 x a2	1.53 - 0.95 x a1 x a2	1.56 - 0.94 x a1 x a2
H2	750	0.95 - 0.07 x a1 x a2	0.96 - 0.06 x a1 x a2	1.00
	1000	1.16 - 0.65 x a1 x a2	1.17 - 0.63 x a1 x a2	1.21 - 0.55 x a1 x a2
	1500	1.54 - 2.40 x a1 x a2	1.55 - 2.40 x a1 x a2	1.58 - 2.20 x a1 x a2
H3	750	0.89 - 0.29 x a1 x a2	0.91 - 0.25 x a1 x a2	1.00
	1000	1.06 - 1.30 x a1 x a2	1.08 - 1.20 x a1 x a2	1.17 - 0.93 x a1 x a2
	1500	1.38 - 4.20 x a1 x a2	1.40 - 4.10 x a1 x a2	1.48 - 3.70 x a1 x a2
B2	750	0.95	0.96	1.00
	1000	1.13 - 0.15 x a1 x a2	1.14 - 0.16 x a1 x a2	1.19 - 0.19 x a1 x a2
	1500	1.47 - 0.95 x a1 x a2	1.48 - 0.92 x a1 x a2	1.52 - 0.95 x a1 x a2
B3	750	0.94	0.96	1.00
	1000	1.13 - 0.17 x a1 x a2	1.14 - 0.18 x a1 x a2	1.18 - 0.25 x a1 x a2
	1500	1.48 - 1.40 x a1 x a2	1.49 - 1.40 x a1 x a2	1.52 - 1.40 x a1 x a2

当 f10 小于 0.5 时, 请咨询。 For factor f10 < 0.5, please refer to us!

注: “*” 按客户要求供货 On request.

当 f9 小于 0.5 时, 请咨询。 For factor f9 < 0.5, please refer to us!

表9 带冷却盘管齿轮箱的热容量系数 f₁₁
Table 9 Thermal capacity factor for gear units with cooling coil

类型 Gear unit type	n 1/min	安装空间 Place of installation		
		狭小空间安装 风速 ≥ 0.5 m/s Small confined spaces Wind velocity ≥ 0.5m/s	大厅或大车间安装 风速 ≥ 1.4 m/s Large halls,workshops Wind velocity ≥ 1.4 m/s	室外安装 风速 ≥ 4.0 m/s In the open Wind velocity ≥ 4.0 m/s
H1	750	0.87	0.91	1.00
	1000	0.97 - 0.02 x a ₁ x a ₂	1.03 - 0.05 x a ₁ x a ₂	1.16 - 0.10 x a ₁ x a ₂
	1500	1.15 - 0.19 x a ₁ x a ₂	1.22 - 0.23 x a ₁ x a ₂	1.39 - 0.33 x a ₁ x a ₂
H2	750	0.88	0.91	1.00
	1000	1.01	1.06 - 0.08 x a ₁ x a ₂	1.17 - 0.24 x a ₁ x a ₂
	1500	1.27 - 0.79 x a ₁ x a ₂	1.33 - 0.88 x a ₁ x a ₂	1.47 - 1.10 x a ₁ x a ₂
H3	750	0.89	0.91	1.00
	1000	1.04	1.07	1.18 - 0.38 x a ₁ x a ₂
	1500	1.38 - 0.78 x a ₁ x a ₂	1.34 - 1.10 x a ₁ x a ₂	1.47 - 1.60 x a ₁ x a ₂
B2	750	0.86	0.90	1.00
	1000	0.98	1.02	1.15 - 0.09 x a ₁ x a ₂
	1500	1.14	1.19 - 0.05 x a ₁ x a ₂	1.38 - 0.37 x a ₁ x a ₂
B3	750	0.88	0.91	1.00
	1000	1.03	1.06	1.17 - 0.18 x a ₁ x a ₂
	1500	1.28 - 0.35 x a ₁ x a ₂	1.32 - 0.48 x a ₁ x a ₂	1.46 - 0.84 x a ₁ x a ₂

表10 带冷却风扇和冷却盘管的齿轮箱的热容量 f₁₂
Table 10 Thermal capacity factor for gear units with fan and cooling coil

类型 Gear unit type	n 1/min	安装空间 Place of installation		
		狭小空间安装 风速 ≥ 0.5 m/s Small confined spaces Wind velocity ≥ 0.5m/s	大厅或大车间安装 风速 ≥ 1.4 m/s Large halls,workshops Wind velocity ≥ 1.4 m/s	室外安装 风速 ≥ 4.0 m/s In the open Wind velocity ≥ 4.0 m/s
H1	750	0.98	0.98	1.00
	1000	1.19 - 0.09 x a ₁ x a ₂	1.20 - 0.09 x a ₁ x a ₂	1.22 - 0.09 x a ₁ x a ₂
	1500	1.56 - 0.31 x a ₁ x a ₂	1.56 - 0.30 x a ₁ x a ₂	1.57 - 0.29 x a ₁ x a ₂
H2	750	0.97	0.98	1.00
	1000	1.19 - 0.25 x a ₁ x a ₂	1.20 - 0.25 x a ₁ x a ₂	1.22 - 0.25 x a ₁ x a ₂
	1500	1.59 - 1.06 x a ₁ x a ₂	1.59 - 1.00 x a ₁ x a ₂	1.61 - 1.00 x a ₁ x a ₂
H3	750	0.94	0.95	1.00
	1000	1.14 - 0.46 x a ₁ x a ₂	1.15 - 0.47 x a ₁ x a ₂	1.20 - 0.48 x a ₁ x a ₂
	1500	1.51 - 2.10 x a ₁ x a ₂	1.52 - 2.00 x a ₁ x a ₂	1.57 - 2.00 x a ₁ x a ₂
B2	750	0.97	0.98	1.00
	1000	1.17 - 0.08 x a ₁ x a ₂	1.18 - 0.08 x a ₁ x a ₂	1.21 - 0.12 x a ₁ x a ₂
	1500	1.55 - 0.47 x a ₁ x a ₂	1.55 - 0.47 x a ₁ x a ₂	1.58 - 0.52 x a ₁ x a ₂
B3	750	0.97	0.97	1.00
	1000	1.17 - 0.08 x a ₁ x a ₂	1.18 - 0.10 x a ₁ x a ₂	1.21 - 0.19 x a ₁ x a ₂
	1500	1.56 - 0.84 x a ₁ x a ₂	1.57 - 0.85 x a ₁ x a ₂	1.60 - 0.92 x a ₁ x a ₂

当f₁₁小于0.5时, 请咨询。

For factor f₁₁<0.5, please refer to us!

当f₁₂小于0.5时, 请咨询。

For factor f₁₂<0.5, please refer to us!

表11 型号系数 a₁
Table 11 Size factor

Size	3	4	5	6	7	8	9	10	11	12	13	14
a ₁	0.024	0.030	0.050	0.055	0.065	0.075	0.085	0.095	0.135	0.160	0.190	0.200
Size	15	16	17	18	19	20	21	22	23	24	25	26
a ₁	0.270	0.290	0.320	0.345	0.370	0.390	0.530	0.610	请来电咨询 Please refer to us.			

表12 速比系数 a₂
Table 12 Transmission ratio factor

i	H1SH	i	H2SH	i	H3SH	i	H4SH	i	B2SH	i	B3SH	i	B4SH
1.25	13.000	6.3	1.800	22.4	0.320	100	0.020	5	3.500	12.5	0.950	80	0.110
1.4	12.000	7.1	1.600	25	0.310	112	0.015	5.6	2.800	14	0.850	90	0.100
1.6	10.000	8	1.400	28	0.270	125	0.012	6.3	2.400	16	0.800	100	0.090
1.8	8.500	9	1.100	31.5	0.230	140	0.009	7.1	1.900	18	0.750	112	0.080
2	8.000	10	0.890	35.5	0.190	160	0.007	8	1.600	20	0.700	125	0.070
2.24	7.000	11.2	0.740	40	0.170	180	0.004	9	1.350	22.4	0.650	140	0.060
2.5	6.500	12.5	0.630	45	0.160	200	0.002	10	1.200	25	0.550	160	0.050
2.8	6.000	14	0.530	50	0.110	224	0	11.2	1.100	28	0.450	180	0.040
3.15	3.500	16	0.450	56	0.080	250	0	12.5	0.950	31.5	0.380	200	0.030
3.55	3.300	18	0.370	63	0.050	280	0	14	0.850	35.5	0.330	224	0.020
4	2.900	20	0.330	71	0.045	315	0	16	0.800	40	0.300	250	0.010
4.5	2.100	22.4	0.320	80	0.040	355	0	18	0.750	45	0.270	280	0
5	1.600	25	0.310	90	0.035	400	0			50	0.200	315	0
5.6	1.600	28	0.270	100	0.020	450	0			56	0.150	355	0
				112	0.015					63	0.130	400	0
										71	0.120		
										80	0.110		
										90	0.100		

注: 减速机在户外安装时, 应该避免阳光的直接照射, 应该按需采取防护措施, 如加盖等, 应避免热力集中。

Note: Gear units installed in open field will avoid direct sunshine by equipping a shelter.

输出轴允许的附加径向力:

Permissible Additional Radial Forces on Output Shaft:

输出轴d2上允许的附加径向力:

Permissible Additional Radial Forces on Output Shaft d2

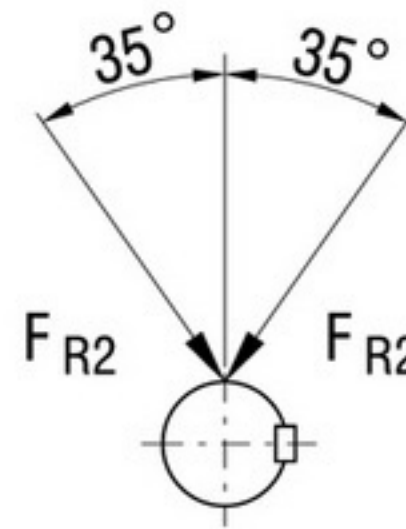
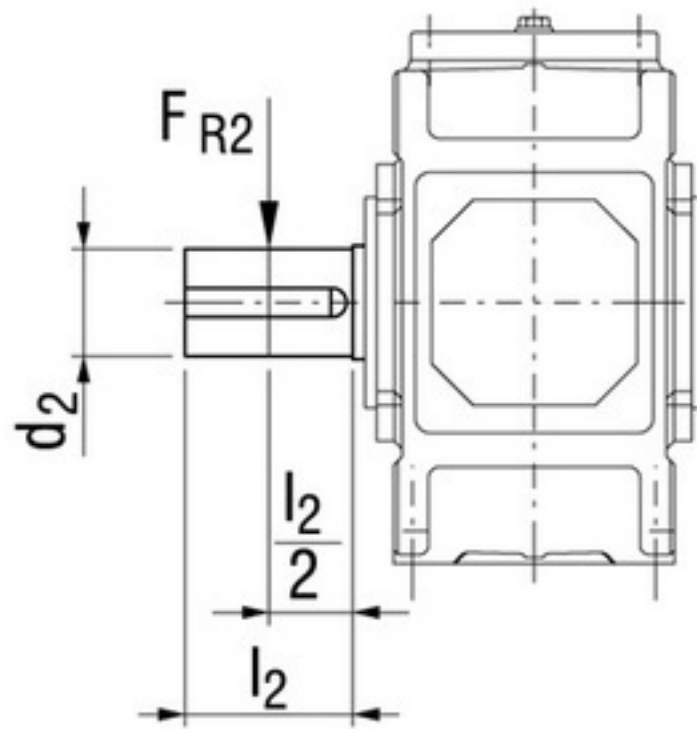

允许的作用力方向
Permissible direction of force

允许的附加径向力Fr2 (kN), 作用于输出轴端中部**
Permissible additional radial forces Fr2 in kN with application of force on centre of shaft end

型号 Type	布置形式 Design	3	4	5	6	7	8	9	10	11	12	13	14	15	16	17	18
H1SH	A/B	*	—	*	—	*	—	*	—	*	—	*	—	*	—	*	—
H2S.	A/B/G/H	—	10	22	22	30	30	30	45	64	64	150	150	140	205	205	205
	C/D	—	10	13	13	18	18	10	28	35	35	112	112	85	135	135	135
H3S.	A/B/G/H	—	—	29	29	40	40	40	60	85	85	190	190	185	265	265	265
	C/D	—	—	18	18	26	26	18	40	50	50	150	150	120	185	185	190
H4S.	A/B	—	—	—	—	26	26	18	40	50	50	150	150	120	185	185	190
	C/D	—	—	—	—	40	40	40	60	85	85	190	190	185	265	265	265
B2S.	A/C	—	13	27	27	37	37	38	55	78	78	160	160	150	210	210	210
	B/D	—	12	15	15	17	17	10	30	35	38	110	110	75	145	100	100
B3S.	A/C	—	14	29	29	40	40	40	60	85	85	190	190	185	265	265	265
	B/D	—	9	18	18	26	26	18	40	50	50	150	150	120	185	185	190
B4S.	A/C	—	—	29	29	40	40	40	60	85	85	190	190	185	265	265	265
	B/D	—	—	18	18	26	26	18	40	50	50	150	150	120	185	185	190

注: 1) 表中数据为最小值。如果给定了力的作用角和回转方向, 通常情况下, 可允许承受较大的附加力。请与我们联系。
2) *按客户要求供货。
3) **当作用力不在轴端中部时, 请参见216页。
4) 基础螺栓的最低性能等级为8.8级。基础必须干燥, 不得有油脂。如用户要求, 允许输入轴d1上附加径向力。

Note: 1) Values in tables are minimum values. If the angle of application of force and the direction of rotation are given, significantly higher additional forces can mostly be allowed. Please consult us.
2) * On request.
3) **For application of force outside the centre of the shaft end, see P216.
4) Use foundation bolts of min. property class 8.8. Foundation must be dry and grease-free. Permissible additional radial forces on input shaft d1 on request.

输出轴d2上允许的附加径向力:

Permissible Additional Radial Forces on Output Shaft d2

作用力不在轴端中部
Application of force outside the centre of the shaft end

$$F_{RZ2} = F_{R2} \times k$$

F_{RZ2} 允许的轴端外部径向力
Permissible external radial force

F_{R2} 允许的附加径向力
根据上一頁的表确定。
Permissible additional radial force
acc. to table

k 作用力系数根据下表确定
Factor of application of force acc. to
table

作用力系数k Factor of application of force k															
机座号 Size	距离 Distance z (mm)														
	- 200	- 150	- 100	- 75	- 50	- 25	0	25	50	75	100	150	200	250	300
3					1.21	1.09	1.00	0.85	0.74	0.65	0.58	0.48			
4					1.17	1.08	1.00	0.86	0.76	0.68	0.62	0.52	0.44		
5、6				1.22	1.14	1.06	1.00	0.88	0.79	0.72	0.66	0.56	0.49	0.43	
7、8				1.19	1.12	1.06	1.00	0.89	0.81	0.74	0.68	0.58	0.51	0.46	0.41
9、10			1.22	1.15	1.10	1.05	1.00	0.90	0.82	0.76	0.70	0.61	0.54	0.48	0.44
11、12			1.18	1.13	1.08	1.04	1.00	0.91	0.84	0.78	0.73	0.64	0.57	0.51	0.47
13、14		1.24	1.15	1.11	1.07	1.03	1.00	0.92	0.86	0.80	0.75	0.67	0.60	0.55	0.50
15、16		1.20	1.12	1.09	1.06	1.03	1.00	0.93	0.87	0.82	0.77	0.69	0.63	0.58	0.53
17、18	1.25	1.17	1.11	1.08	1.05	1.03	1.00	0.94	0.88	0.84	0.79	0.72	0.66	0.60	0.56

1系列传动能力表(i=1.25-5.6):

H1 series transmission capacity table(i=1.25-5.6):

i1	n _{2N} (r/min)	i _N	H1-3			H1-5			H1-7			H1-9			H1-11			H1-13			H1-15			H1-17			H1-19			
			T _{2N} (kN·m)	i _{ex}	P _{1N} (kW)	T _{2N} (kN·m)	i _{ex}	P _{1N} (kW)	T _{2N} (kN·m)	i _{ex}	P _{1N} (kW)	T _{2N} (kN·m)	i _{ex}	P _{1N} (kW)	T _{2N} (kN·m)	i _{ex}	P _{1N} (kW)	T _{2N} (kN·m)	i _{ex}	P _{1N} (kW)	T _{2N} (kN·m)	i _{ex}	P _{1N} (kW)	T _{2N} (kN·m)	i _{ex}	P _{1N} (kW)	T _{2N} (kN·m)	i _{ex}	P _{1N} (kW)	
100	1200	1.25	2.6	1.243	327	7	1.256	880	13.3	1.263	1671	21.5	1.270	2702																
	218				586			1114			1801																			
	163				440			836			1351																			
100	1071	1.4	2.7	1.371	303	7.2	1.378	807	13.9	1.389	1559	22.3	1.400	2501																
	202				538			1039			1667																			
	152				404			780			1252																			
100	938	1.6	2.9	1.594	285	7.5	1.588	737	14.2	1.606	1395	23.6	1.625	2318	40	1.636	2618	63	1.588	3929										
	190				491			929			1545																			
	142				368			697			1159																			
100	833	1.8	2.4	1.829	209	7.7	1.839	672	15.2	1.774	1326	24.4	1.800	2128	41.4	1.806	2410	66.3	1.839	3611										
	140				448			885			1421																			
	105				336			664			1065																			
100	750	2.0	2.5	2.000	196	8.2	2.034	644	15.5	1.966	1217	25	2.000	1963	42.7	2.000	2236	68.2	2.034	3353	121	2.000								
	131				429			812			1309																			
	98				322			609			982																			
100	670	2.24	2.5	2.194	175	8.4	2.259	589	15.5	2.308	1087	25	2.231	1754	44	2.222	2055	70.3	2.259	3087	122	2.231								
	117				392			724			1168																			
	88				295			544			877																			
100	600	2.5	2.6	2.536	163	8.4	2.520	528	15.5	2.583	974	25	2.500	1571	44	2.480	1843	72	2.520	2764	110	2.481	4607							
	109				352			649			1047																			
	82				264			487			785																			
100	536	2.8	2.7	2.808	152	8.4	2.826	471	14.9	2.800	836	23.7	2.741	1330	44	2.783	1645	72	2.826	2470	113	2.760	4224	171	2.760					
	101				314			557			886																			
	76				236			418			665																			
100	476	3.15	2.7	3.125	135	8.4	3.190	419	15.2	3.130	758	24.5	3.208	1221	41.9	3.080	1391	68.4	3.208	2088	116	3.087	3850	173	3.087					
	90				279			505			813																			
	67				209			379			611																			
100	423	3.55	2.8	3.500	124	8.3	3.591	368	15.5	3.524	687	24.9	3.591	1103	43.7	3.478	1290	69.6	3.591	1936	118	3.476	3484	173	3.476					
	83				245			458			735																			
	62				183			342			550																			
100	375	4.0	2.8	3.950	110	8.4	4.050	330	15.5	4.000	609	25	4.050	982	44	3.905	1152	70.8	4.050	1728	122	3.947	3194	173	3.947	4529	245	3.994		
	73				220			406			654																			
	55				165			305			492																			
100	333	4.5	2.2	4.435	77	6.7	4.619	234	13.8	4.400	481	21.4	4.381	746	40	4.421	930	57.6	4.619	1395	102	4.579	2371	146	4.526	3394	216	4.400		
	51				156			321			497																			
	38				117			241			374																			
100	300	5.0	2.1	4.952	66	6.3	4.900	198	12	4.905	377	20.5	4.947	644	33.7	5.150	706	54.5	4.900	1059	88.8	5.100	1860	124	4.900	2597	174	4.950	3644	
	44				132			251			429																			
	33				99			188			322																			
100	268	5.6	2	5.579	56	6	5.556	168	11.4	5.526	320	17.5	5.684	491	31.8	5.474	596	51.8	5.556	1454	84.5	5.778	1584	118	5.556	2212	150	5.700	2812	
	37				112			214			328																			
	28				84			160			246																			

: 卧式安装齿轮箱要求采用强制润滑。

Note: Forced lubrication required on horizontal gear units.

H系列传动能力表(i=6.3-35.5):

H series transmission capacity table(i=6.3-35.5):

n ₁ (r/min)	n _{2N} (r/min)	i _N	H-4			H-5			H-6			H-7			H-8			H-9			
			T _{2N} (kN·m)	i _{ex}	P _{1N} (kW)	T _{2N} (kN·m)	i _{ex}	P _{1N} (kW)	T _{2N} (kN·m)	i _{ex}	P _{1N} (kW)	T _{2N} (kN·m)	i _{ex}	P _{1N} (kW)	T _{2N} (kN·m)	i _{ex}	P _{1N} (kW)	T _{2N} (kN·m)	i _{ex}	P _{1N} (kW)	
1500	238	6.3	6.3	6.319	157	10.5	6.286					19	6.088	474				31.5	6.260	785	
1000	159				105									175						316	524
750	119				79									131						237	393
1500	211	7.1	6.3	6.857	139	10.5	7.213					19	7.048	420				31.5	7.247	696	
1000	141				93									155						281	465
750	106				70									117						211	350
1500	188	8.0	6.3	7.778	124	10.5	7.889	13.5	7.792	266	19	7.799	24	374	7.676	472	31.5	8.018	620		
1000	125				82					137				249		412					
750	94				62					103				187		310					
1500	167	9	6.3	8.485	110	10.5	8.652	13.5	8.940	236	19	8.660	24	332	8.887	420	31.5	8.904	551		
1000	111				73					122				221		366					
750	83				55					91				165		274					
1500	150	10	6.3	9.722	99	10.5	10.002	13.5	9.778	212	19	9.660	24	298	9.833	377	31.5	9.932	495		
1000	100				66					110				199		330					
750	75				49					82				149		247					
1500	134	11.2	6.3	10.694	88	10.5	11.075	13.5	10.724	189	19	10.648	24	267	10.920	337	31.5	11.138	442		
1000	89				59					98				177		294					
750	67				44					74				133		221					
1500	120	12.5	6.3	12.444	79	10.5	12.326	13.5	12.397	170	19	11.807	24	239	12.180	302	31.5	12.574	396		
1000	80				53					88				159		264					
750	60				40					66				119		198					
1500	107	14	6.3	13.865	71	10.5	13.806	13.5	13.726	151	19	13.939	24	213	13.426	269	31.5	14.152	353		
1000	71				47					78				141		234					
750	54				36					59				107		178					
1500	94	16	6.3	15.556	62	10.5	15.581	13.5	15.278	133	19	15.717	24	187	14.887	236	31.5	15.962	310		
1000	63				42					69				125		208					
750	47				31					52				94		155					
1500	83	18	6.3	17.602	55	10.5	17.493	13.5	17.111	117	19	17.598	24	165	17.576	209	31.5	18.204	274		
1000	56				37					62				111		185					
750	42				28					46				84		139					
1500	75	20	6.3	19.444	49	10.5	19.534	13.5	19.311	106	19	19.742	24	149	19.817	188	31.5	19.312	247		
1000	50				33					55				99		165					
750	38				25					42				76		125					
1500	67	22.4	6.2	22.037	43	10.2	22.006	13.5	21.681	95	18.6	20.982	24	130	22.189	168	31	21.895	217		
1000	45				29					48				88		146					
750	33				21					35				64		107					
1500	60	25				11	25.011	13.5	24.212	85	20.5	25.540	24	129	24.892	151	34	25.439	214		
1000	40									46				57		86			142		
750	30									35				42		64			107		
1500	54	28				11	28.490	13	27.275	74	20.5	27.711	23.5	116	26.456	133	34	29.187	192		
1000	36									41				49		77			128		
750	27									31				37		58			96		
1500	48	31.5				11	31.161	14.5	30.999	73	20.5	31.433	25.5	103	32.202	128	34	31.924	171		
1000	32									37				49		69			114		
750	24									28				36		52			85		
1500	42	35.5				11	34.177	14.5	35.312	64	20.5	34.291	25.5	90	34.940	112	34	35.013	150		
1000	28									32				43		60			100		
750	21									24				32		45			75		

H-10			H-11			H-12			H-13			H-14			H-15			i _N	n _{2N} (r/min)	n ₁ (r/min)
T _{2N} (kN·m)	i _{ex}	P _{1N} (kW)	T _{2N} (kN·m)	i _{ex}	P _{1N} (kW)	T _{2N} (kN·m)	i _{ex}	P _{1N} (kW)	T _{2N} (kN·m)	i _{ex}	P _{1N} (kW)	T _{2N} (kN·m)	i _{ex}	P _{1N} (kW)	T _{2N} (kN·m)	i _{ex}	P _{1N} (kW)			
					1383						2143						3564		238	1500
			55.5	6.246	924				86	6.410	1432				143	6.449	2381	6.3	159	1000
					692						1072						1782		119	750
			55.5	6.900	1226				86	7.100	1900				143	7.120	3159	7.1	211	1500
					819						1270						2111		141	1000
					616						955						1587		106	750
39.5	7.848	778			1093			1358			1693			2106			2815		188	1500
		517	55.5	7.644	726	69	7.941	903	86	7.889	1126	107	7.944	1401	143	7.882	1872	8.0	125	1000
		389			546			679			846			1053			1408		94	750
39.5	9.085	691			971			1207			1504			1871			2501		167	1500
		459	55.5	8.974	645	69	8.772	802	86	8.799	1000	107	8.800	1244	143	8.758	1662	9	111	1000
		343			482			600			747			930			1243		83	750
39.5	10.053	620			872			1084			1351			1681			2246		150	1500
		414	55.5	10.046	581	69	9.718	723	86	9.861	901	107	9.778	1120	143	9.774	1497	10	100	1000
		310			436			542			675			840			1123		75	750
39.5	11.163	554			779			968			1207			1501			2006		134	1500
		368	55.5	10.889	517	69	11.410	643	86	10.811	801	107	10.906	997	143	10.967	1333	11.2	89	1000
		277			389			484			603			751			1003		67	750
39.5	12.452	496			697			867			1081			1345			1797		120	1500
		331	55.5	12.174	465	69	12.773	578	86	12.655	720	107	12.222	896	143	12.139	1198	12.5	80	1000
		248			349			434			540			672			898		60	750
39.5	13.964	443			622			773			964			1199			1602		107	1500
		294	55.5	13.704	413	69	13.844	513	86	14.164	639	107	13.399	795	143	13.708	1063	14	71	1000
		223			314			390			486			605			809		54	750
39.5	15.765	389			546			679			846			1053			1408		94	1500
		261	55.5	15.556	366	69	15.478	455	86	15.975	567	107	15.685	706	143	15.389	943	16	63	1000
		194			273			340			423			527			704		47	750
39.5	17.743	343			482			600			747			930			1243		83	1500
		232	55.5	17.111	325	69	17.423	405	86	17.280	504	107	17.556	627	143	17.424	839	18	56	1000
		174			244			303			378			471			629		42	750
39.5	20.012	310			436			542			675			840			1123		75	1500
		207	55.5	19.074	291	69	19.778	361	86	19.515	450	107	19.800	560	143	20.297	749	20	50	1000
		157			221			275			342			426			569		38	750
39.5	22.824	277			382			484			617			751			1073		67	1500
		186	54.5	21.491	257	69	21.756	325	88	22.020	415	107	21.418	504	153	21.374	721	22.4	45	1000
		136			188			238			304			370			529		33	750
39.5	24.212	248			377			434			553			672			961		60	1500
		165	60	24.706	251	69	24.251	289	88	25.372	369	107	24.187	448	153	24.716	641	25	40	1000
		124			188			217			276			336			481		30	750
38.9	27.451	220			339			383			498			616			865		54	1500
		147	60	28.602	226	67.8	27.325	256	88	29.373	332	109	27.292	411	153	27.304	577	28	36	1000
		110			170			192			249			308			433		27	750
43	31.894	216			302			377			442			548			769		48	1500
		144	60	31.648	201	75	31.412	251	88	32.501	295	109	31.447	365	153	30.248	513	31.5	32	1000
		108			151			188			221			274			385		24	750
43	36.593	189			264			330			387			479			673		42	1500
		126	60	35.144	176	75	36.366	220	88	36.092	258	109	36.406	320	153	35.514	449	35.5	28	1000
		95			132			165			194			240			336		21	750

注：□ 卧式安装齿轮箱要求采用强制润滑。

Note: □ Forced lubrication required on horizontal gear units.

H系列传动能力表(i=6.3-35.5):

(续前页)

H series transmission capacity table(i=6.3-35.5):

n ₁ (r/min)	n _{2N} (r/min)	i _N	H-16			H-17			H-18			H-19			H-20			H-21			
			T _{2N} (kN·m)	i _{ex}	P _{1N} (kW)	T _{2N} (kN·m)	i _{ex}	P _{1N} (kW)	T _{2N} (kN·m)	i _{ex}	P _{1N} (kW)	T _{2N} (kN·m)	i _{ex}	P _{1N} (kW)	T _{2N} (kN·m)	i _{ex}	P _{1N} (kW)	T _{2N} (kN·m)	i _{ex}	P _{1N} (kW)	
1500	238	6.3						4860													
1000	159					195	6.154	3247				292	6.410	4862						6.500	
750	119							2430						3639							
1500	211	7.1			3535			4308													
1000	141		160	7.316	2362	195	7.125	2879	230	7.147	3396	292	7.100	4311	335	7.312	4946	410	7.200		
750	106				1776			2164			2553			3241			3718			4551	
1500	188	8.0			3150			3839													
1000	125		160	8.076	2094	195	7.884	2552	230	8.274	3010	292	7.889	3822	335	8.100	4385	410	8.000	5366	
750	94				1575			1919			2264			2874			3297			4036	
1500	167	9			2798			3410													
1000	111		160	8.941	1860	195	8.755	2266	230	9.155	2673	292	8.799	3394	335	9.000	3894	410	8.923	4765	
750	83				1391			1695			1999			2538			2912			3563	
1500	150	10			2513			3063													
1000	100		160	9.935	1675	195	9.765	2042	230	10.167	2408	292	9.788	3058	335	10.038	3508	410	9.926	4293	
750	75				1257			1531			1806			2293			2631			3220	
1500	134	11.2			2245			2736													
1000	89		160	11.087	1491	195	10.951	1817	230	11.340	2143	292	10.887	2721	335	11.167	3122	410	11.040	3821	
750	67				123			1368			1614			2049			2350			2876	
1500	120	12.5			2010			2450													
1000	80		160	12.440	1340	195	12.432	1634	230	12.717	1927	292	12.176	2446	335	12.420	2806	410	12.348	3435	
750	60				1005			1225			1445			1835			2105			2576	
1500	107	14			1793			2185													
1000	71		160	13.769	190	195	13.914	1450	230	14.438	1710	292	13.712	2171	335	13.891	2491	410	13.905	3048	
750	54				905			1103			1301			1651			1894			2318	
1500	94	16			1575			1919													
1000	63		160	15.550	1055	195	15.694	1286	230	16.159	1517	292	15.570	1926	335	15.643	2210	410	15.789	2705	
750	47				787			960			132			1437			1649			2018	
1500	83	18			1391			1695													
1000	56		160	17.457	938	195	17.899	1143	230	18.225	1349	292	18.061	1712	335	17.763	1964	410	18.316	2404	
750	42				704			858			1012			1284			1473			1803	
1500	75	20			1257			1531													
1000	50		160	19.765	838	195	18.988	1021	230	20.786	1204	292	20.117	1529	335	20.605	1754	410	20.400	2147	
750	38				637			776			915			1162			1333			1631	
1500	67	22.4			123			1403													
1000	45		160	23.024	754	200	20.930	942	230	22.050	1084	300	21.782	1414	335	22.950	1579	420	22.368	1979	
750	33				553			691			795			1037			158			1451	
1500	60	25			1087			1257													
1000	40		173	24.245	725	200	24.202	838	240	24.306	1005	300	25.283	1257	345	24.850	1445	420	25.837	1759	
750	30				543			628			754			942			1084			1319	
1500	54	28			978			1131													
1000	36		173	28.036	652	200	26.736	754	240	28.106	905	300	28.006	1131	345	28.844	1301	420	28.523	1583	
750	27				489			565			679			848			975			1187	
1500	48	31.5			870			1005													
1000	32		173	30.971	580	200	29.619	670	240	31.048	804	300	31.117	1005	345	31.950	156	420	31.579	1407	
750	24				435			503			603			754			867			1055	
1500	42	35.5			761			880													
1000	28		173	34.311	507	200	34.776	586	240	34.397	704	300	34.708	880	345	35.500	1012	420	35.088	1231	
750	21				308			440			528			660			759			924	

注: 卧式安装齿轮箱要求采用强制润滑。

Note: Forced lubrication required on horizontal gear units.

H-22			H-23			H-24			H-25			H-26			i _N	n _{2N} (r/min)	n ₁ (r/min)
T _{2N} (kN·m)	i _{ex}	P _{1N} (kW)	T _{2N} (kN·m)	i _{ex}	P _{1N} (kW)	T _{2N} (kN·m)	i _{ex}	P _{1N} (kW)	T _{2N} (kN·m)	i _{ex}	P _{1N} (kW)	T _{2N} (kN·m)	i _{ex}	P _{1N} (kW)			
				6.306						6.280					6.3	238	1500
																159	1000
																119	750
	7.265			7.038			7.059			6.915			7.232		7.1	211	1500
																141	1000
																106	750
458	8.047			7.882			7.878			7.635			7.963		8.0	188	1500
		4508														125	1000
																94	750
458	8.941	5323	540	8.868			8.824			8.915			8.792		9	167	1500
		3981														111	1000
																83	750
458	9.973	4796	540	9.780		620	9.926			9.939			10.266		10	150	1500
		3597														100	1000
																75	750
458	11.094	4268	540	10.878	5032	620	10.948		780	11.141			11.445		11.2	134	1500
		3213			3788											89	1000
																67	750
458	12.339	3837	540	12.166	4524	620	12.176		780	12.571		880	12.829		12.5	120	1500
		2877			3393											80	1000
																60	750
458	13.801	3405	540	13.700	4015	620	13.619	4609	780	13.394		880	14.476		14	107	1500
		2590			3053			3506					4976			71	1000
																54	750
458	15.541	3021	540	15.557	3562	620	15.336	4090	780	15.314	5146	880	15.424		16	94	1500
		2254			2658			3051			3839		4331			63	1000
																47	750
458	17.647	2686	540	17.839	3166	620	17.415	3636	780	17.082	4574	880	17.634	5160	18	83	1500
		2014			2375			2727			3430		3870			56	1000
																42	750
458	20.471	2398	540	19.312	2827	620	19.969	3246	780	19.218	4084	880	19.671	4607	20	75	1500
		1822			2149			2467			3104		3502			50	1000
																38	750
458	22.800	2158	560	22.039	3929	620	21.618	2921	800	21.108	3770	880	22.129	4147	22.4	67	1500
		1583			2639			2142			2764		3041			45	1000
					1935											33	750
470	25.000	2953	560	25.457	3518	640	24.671	4021	800	24.322	5026	900	24.306	3770	25	60	1500
		1969			2346			2681			3351			2827		40	1000
		1476			1759			2010			2513					30	750
470	28.877	2658	560	28.103	3166	640	28.497	3619	800	28.157	4524	900	28.007	5089	28	54	1500
		1772			2111			2413			3016			3393		36	1000
		1329			1583			1809			2262			2545		27	750
470	31.879	2362	560	31.115	2815	640	31.459	3217	800	31.156	4021	900	32.424	4524	31.5	48	1500
		1575			1876			2145			2681			3016		32	1000
		181			1407			1608			2010			2262		24	750
470	35.294	2067	560	34.572	2463	640	34.830	2815	800	34.598	3518	900	35.876	3958	35.5	42	1500
		1378			1642			1876			2346			2639		28	1000
		1034			1231			1407			1759			1979		21	750

注：□ 卧式安装齿轮箱要求采用强制润滑。

Note: □ Forced lubrication required on horizontal gear units.

H系列传动能力表(i=40-450):

H series transmission capacity table(i=40-450):

n ₁ (r/min)	n _{2N} (r/min)	i _N	H-5			H-6			H-7			H-8			H-9					
			T _{2N} (kN·m)	i _{ex}	P _{1N} (kW)	T _{2N} (kN·m)	i _{ex}	P _{1N} (kW)	T _{2N} (kN·m)	i _{ex}	P _{1N} (kW)	T _{2N} (kN·m)	i _{ex}	P _{1N} (kW)	T _{2N} (kN·m)	i _{ex}	P _{1N} (kW)			
1500	38	40	11	39.508	44	14.5	38.622	58	20.5	39.292	82	25.5	39.633	101	34	40.474	135			
1000	25				29									38			54	67	89	
750	18.8				22									29			40	50	67	
1500	33	45	11	43.745	38	14.5	42.360	50	20.5	43.221	71	25.5	43.236	88	34	44.816	117			
1000	22				25			33			47			59			78			
750	16.7				19			25			36			45			59			
1500	30	50	11	48.689	35	14.5	48.967	46	20.5	50.293	64	25.5	49.542	80	34	49.881	107			
1000	20				23			30			43			53			71			
750	15				17			23			32			40			53			
1500	27	56	11	54.532	31	14.5	54.220	41	20.5	56.033	58	25.5	54.496	72	34	55.866	96			
1000	17.9				21			27			38			48			64			
750	13.4				15			20			29			36			48			
1500	24	63	11	61.543	28	14.5	60.347	36	20.5	62.867	52	25.5	63.413	64	34	63.049	85			
1000	15.9				18			24			34			42			57			
750	11.9				14			18			26			32			42			
1500	21	71	11	69.742	24	14.5	67.589	32	20.5	71.139	45	25.5	70.651	56	34	70.787	75			
1000	14.1				16			21			30			38			50			
750	10.6				12			16			23			28			38			
1500	18.8	80	11	78.723	22	14.5	76.279	29	20.5	78.583	40	25.5	79.267	50	34	79.049	67			
1000	12.5				14			19			27			33			45			
750	9.4				11			14			20			25			33			
1500	16.7	90	11	86.806	19	14.5	86.440	25	20	89.061	35	25.5	89.696	45	33.5	89.050	59			
1000	11.1				13			17			23			30			39			
750	8.3				10			13			17			22			29			
1500	15	100				14.5	97.572	23	20.5	101.554	32	25.5	99.083	40	34	101.210	53			
1000	10										15			21			27	34	36	
750	7.5										11			16			20	27	27	
1500	13.4	112				14.1	107.590	20	20.5	115.256	29	25.2	112.294	35	34	115.290	48			
1000	8.9										13			19			23	34	32	
750	6.7										10			14			18	23	24	
1500	12	125							20.5	125.733	26	25.5	128.046	32	34	126.098	43			
1000	8										17			21			28			
750	6										13			16			21			
1500	10.7	140							20.5	143.985	23	25.5	145.322	29	34	138.301	38			
1000	7.1										15			19			25			
750	5.4										12			14			19			
1500	9.4	160							20.5	158.251	20	25.5	158.533	25	34	159.874	33			
1000	6.3										14			17			22			
750	4.7										10			13			17			
1500	8.3	180							20.5	174.630	18	25.5	181.546	22	34	177.022	30			
1000	5.6										12			15			20			
750	4.2										9.0			11			15			
1500	7.5	200							20.5	193.629	16	25.5	199.533	20	34	197.028	27			
1000	5										11			13			18			
750	3.8										8.2			10			14			
1500	6.7	224							20.5	228.606	14	25.5	220.185	18	34	220.671	24			
1000	4.5										10			12			16			
750	3.3										7.1			8.8			12			
1500	6	250							20.5	257.753	13	25.5	244.141	16	34	249.043	21			
1000	4										8.6			11			14			
750	3										6.4			8.0			11			
1500	5.4	280							20.5	288.615	12	25.5	288.242	14	34	282.219	19			
1000	3.6										7.7			9.6			13			
750	2.7										5.8			7.2			10			
1500	4.8	315							20.5	305.352	10.3	25.5	324.993	13	34	318.563	17			
1000	3.2										7			8.5			11			
750	2.4										5.2			6.4			8.5			
1500	4.2	355							19.6	344.112	8.6	25.5	363.906	11	33	351.273	15			
1000	2.8										5.7			7.5			9.7			
750	2.1										4.3			5.6			7.3			
1500	3.8	400										25.5	385.010	10.1						
1000	2.5																	6.7		
750	1.9																	5.1		
1500	3.3	450										24.8	433.881	8.6						
1000	2.2																	5.7		
750	1.7																	4.4		

H-10			H-11			H-12			H-13			H-14			H-15			i _N	n _{2N} (r/min)	n ₁ (r/min)
T _{2N} (kN·m)	i _{ex}	P _{1N} (kW)	T _{2N} (kN·m)	i _{ex}	P _{1N} (kW)	T _{2N} (kN·m)	i _{ex}	P _{1N} (kW)	T _{2N} (kN·m)	i _{ex}	P _{1N} (kW)	T _{2N} (kN·m)	i _{ex}	P _{1N} (kW)	T _{2N} (kN·m)	i _{ex}	P _{1N} (kW)			
43	40.024	171	60	39.200	239	75	40.238	298	88	40.257	350	109	40.283	434	153	39.756	609	40	38	1500
		113			157			196			230			285			401		25	1000
		85			118			148			173			215			301		18.8	750
43	43.897	149	60	43.210	207	75	44.683	259	88	45.147	304	109	44.733	377	153	43.090	529	45	33	1500
		99			138			173			203			251			352		22	1000
		75			105			131			154			191			268		16.7	750
43	50.744	135	60	47.911	188	75	49.840	236	88	50.968	276	109	49.896	342	153	48.175	481	50	30	1500
		90			126			157			184			228			320		20	1000
		68			94			118			138			171			240		15	750
43	56.187	122	60	56.566	170	75	54.938	212	88	57.365	249	109	55.957	308	153	54.229	433	56	27	1500
		81			112			141			165			204			287		17.9	1000
		60			84			105			123			153			215		13.4	750
43	62.537	108	60	63.778	151	75	60.916	188	88	64.699	221	109	63.171	274	153	61.557	385	63	24	1500
		72			100			125			147			181			255		15.9	1000
		54			75			93			110			136			191		11.9	750
43	70.041	95	60	71.414	132	75	71.919	165	88	73.789	194	109	71.100	240	153	67.713	336	71	21	1500
		63			89			111			130			161			226		14.1	1000
		48			67			83			98			121			170		10.6	750
43	79.046	85	60	80.111	118	75	81.089	148	88	78.278	173	109	80.190	215	153	75.481	301	80	18.8	1500
		56			79			98			115			143			200		12.5	1000
		42			59			74			87			107			151		9.4	750
43	88.748	75	60	85.146	105	75	90.798	131	88	88.750	154	109	91.457	191	153	85.046	268	90	16.7	1500
		50			70			87			102			127			178		11.1	1000
		37			52			65			76			95			133		8.3	750
43	99.106	68	60	103.639	94	75	101.856	118	88	103.114	138	109	97.020	171	153	97.768	240	100	15	1500
		45			63			79			92			114			160		10	1000
		34			47			59			69			86			120		7.5	750
42	111.645	59	60	112.450	84	75	108.257	105	88	118.306	123	109	110.000	153	153	113.186	215	112	13.4	1500
		39			56			70			82			102			143		8.9	1000
		29			42			53			62			76			107		6.7	750
43	126.890	54	60	127.556	75	75	131.769	94	88	129.398	111	109	127.803	137	153	125.238	192	125	12	1500
		36			50			63			74			91			128		8	1000
		27			38			47			55			68			96		6	750
43	144.542	48	60	139.152	67	75	142.973	84	88	141.920	99	109	146.633	122	153	139.074	171	140	10.7	1500
		32			45			56			65			81			114		7.1	1000
		24			34			42			50			62			87		5.4	750
43	158.093	42	60	159.444	59	75	162.178	74	88	164.058	87	109	160.380	107	153	155.125	151	160	9.4	1500
		28			40			49			58			72			101		6.3	1000
		21			30			37			43			54			75		4.7	750
43	173.392	37	60	175.389	52	75	176.921	65	88	181.654	76	109	175.901	95	153	170.993	133	180	8.3	1500
		25			35			44			52			64			90		5.6	1000
		19			26			33			39			48			67		4.2	750
43	200.439	34	60	204.089	47	75	202.722	59	88	202.184	69	109	203.339	86	153	189.597	120	200	7.5	1500
		23			31			39			46			57			80		5	1000
		17			24			30			35			43			61		3.8	750
43	221.938	30	60	227.382	42	75	222.994	53	88	226.446	62	109	225.149	76	153	223.845	107	224	6.7	1500
		20			28			35			41			51			72		4.5	1000
		15			21			26			30			38			53		3.3	750
43	247.020	27	60	255.111	38	75	259.484	47	88	255.560	55	109	250.594	68	153	252.385	96	250	6	1500
		18			25			31			37			46			64		4	1000
		14			19			24			28			34			48		3	750
43	276.663	24	60	288.678	34	75	289.100	42	88	286.925	50	109	280.665	62	153	282.605	87	280	5.4	1500
		16			23			28			33			41			58		3.6	1000
		12			17			21			25			31			43		2.7	750
43	312.234	22	60	318.889	30	75	324.356	38	88	320.413	44	109	316.751	55	153	317.021	77	315	4.8	1500
		14			20			25			29			37			51		3.2	1000
		11			15			19			22			27			38		2.4	750
43	353.827	19	59	361.407	26	75	367.034	33	88	360.951	39	109	355.625	48	140	336.946	62	355	4.2	1500
		13			17			22			26			32			41		2.8	1000
		9.5			13			16			19			24			31		2.1	750
43	399.393	17			30	75	405.444	30			43	109	397.131	43				400	3.8	1500
		11			20			20			29								2.5	1000
		8.6			15			15			22								1.9	750
41.6	440.402	14			26	74	459.504	26			38	109	447.376	38				450	3.3	1500
		9.6			17			17			25								2.2	1000
		7.4			13			13			19								1.7	750

H系列传动能力表(i=40-450): (续前页)

H series transmission capacity table(i=40-450):

n ₁ (r/min)	n _{2N} (r/min)	i _N	H-16			H-17			H-18			H-19			H-20													
			T _{2N} (kN·m)	i _{ex}	P _{1N} (kW)	T _{2N} (kN·m)	i _{ex}	P _{1N} (kW)	T _{2N} (kN·m)	i _{ex}	P _{1N} (kW)	T _{2N} (kN·m)	i _{ex}	P _{1N} (kW)	T _{2N} (kN·m)	i _{ex}	P _{1N} (kW)											
1500	38	40	173	40.284	688	200	38.929	796	240	40.385	628	300	38.897	1194	345	39.596	1373											
1000	25				453												524	472	785	903								
750	18.8				341												394	429	591	679								
1500	33	45	173	45.096	598	200	42.194	691	240	45.208	829	300	42.642	1037	345	44.375	1192											
1000	22				399												461	553	691	795								
750	16.7				303												350	420	525	603								
1500	30	50	173	48.878	543	200	47.174	628	240	49.000	754	300	49.917	942	345	48.648	1084											
1000	20				362												419	503	628	723								
750	15				272												314	377	471	542								
1500	27	56	173	54.647	489	200	53.102	565	240	54.783	679	300	55.870	848	345	56.948	975											
1000	17.9				324												375	450	562	647								
750	13.4				243												281	337	421	484								
1500	24	63	173	61.514	435	200	60.278	503	240	61.667	603	300	63.013	754	345	63.739	867											
1000	15.9				288												333	400	499	574								
750	11.9				216												249	299	374	430								
1500	21	71	173	69.826	380	200	66.306	440	240	70.000	528	300	68.162	660	345	71.888	759											
1000	14.1				255												295	354	443	509								
750	10.6				192												222	266	333	383								
1500	18.8	80	173	76.809	341	200	73.912	394	240	77.000	472	300	76.974	591	345	77.762	679											
1000	12.5				226												262	314	393	452								
750	9.4				170												197	236	295	340								
1500	16.7	90	173	85.620	303	200	83.279	350	240	85.833	420	290	88.439	507	345	87.816	603											
1000	11.1				201												232	279	337	401								
750	8.3				150												174	209	252	300								
1500	15	100	173	96.471	272	200	95.735	314	226	96.711	355	300	100.079	471	335	100.895	526											
1000	10				181												209	237	314	351								
750	7.5				136												157	177	236	263								
1500	13.4	112	173	110.901	243	200	110.833	281	240	111.176	337	300	115.862	421	345	114.174	484											
1000	8.9				161												186	224	280	322								
750	6.7				121												140	168	210	242								
1500	12	125	173	128.390	217	200	122.634	251	240	128.710	302	300	128.198	377	345	132.180	434											
1000	8				145												168	201	251	289								
750	6				109												126	151	188	217								
1500	10.7	140	173	142.060	194	200	136.183	224	240	142.414	269	300	142.362	336	345	146.254	387											
1000	7.1				129												149	178	223	256								
750	5.4				98												113	136	170	195								
1500	9.4	160	173	157.756	170	200	151.900	197	240	158.148	236	300	158.792	295	345	162.413	340											
1000	6.3				114												132	158	198	228								
750	4.7				85												98	118	148	170								
1500	8.3	180	173	175.962	150	200	167.438	174	240	176.400	209	300	178.079	261	345	181.156	300											
1000	5.6				101												117	141	176	202								
750	4.2				76												88	106	132	152								
1500	7.5	200	173	193.962	136	200	185.656	157	240	194.444	188	300	201.040	236	345	203.160	271											
1000	5				91												105	126	157	181								
750	3.8				69												80	95	119	137								
1500	6.7	224	173	215.065	121	200	219.192	140	240	215.600	168	300	226.272	210	345	229.355	242											
1000	4.5				82												94	113	141	163								
750	3.3				60												69	83	104	119								
1500	6	250	173	253.914	109	200	247.139	126	240	254.545	151	300	255.201	188	345	258.141	217											
1000	4				72												84	101	126	145								
750	3				54												63	75	94	108								
1500	5.4	280	173	286.288	98	200	276.730	113	240	287.000	136	300	291.058	170	345	291.144	195											
1000	3.6				65												75	90	113	130								
750	2.7				49												57	68	85	98								
1500	4.8	315	173	320.566	87	200	310.431	101	240	321.364	121	300	308.761	151	345	332.052	173											
1000	3.2				58												67	80	101	116								
750	2.4				43												50	60	75	87								
1500	4.2	355	173	359.606	76	192	329.942	84	240	360.500	106	290	350.069	128	345	352.249	152											
1000	2.8				51												56	70	85	101								
750	2.1				38												42	53	64	76								
1500	3.8	400	158	382.207	63			89	223	383.158	89				335	399.375	133											
1000	2.5				41													58		88								
750	1.9				31													44		67								
1500	3.3	450																										
1000	2.2																											
750	1.7																											

H-21			H-22			H-23			H-24			H-25			H-26			i _N	n _{2N} (r/min)	n ₁ (r/min)		
T _{2N} (kN·m)	i _{ex}	P _{1N} (kW)	T _{2N} (kN·m)	i _{ex}	P _{1N} (kW)	T _{2N} (kN·m)	i _{ex}	P _{1N} (kW)	T _{2N} (kN·m)	i _{ex}	P _{1N} (kW)	T _{2N} (kN·m)	i _{ex}	P _{1N} (kW)	T _{2N} (kN·m)	i _{ex}	P _{1N} (kW)					
420	39.158	1671	470	39.216	1870	560	38.582	2228	640	38.700	2547	800	38.591	3183	900	39.840	3581	40	38	1500		
		1099			1230			1466			1675			2094			2356		25	1000		
		827			925			1102			1260			1575			1772		18.8	750		
420	43.936	1451	470	43.765	1624	560	43.290	1935	640	43.189	2212	800	43.278	2764	900	44.438	3110	45	33	1500		
		968			1083			1290			1474			1843			2073		22	1000		
		734			822			979			1119			1399			1574		16.7	750		
420	48.632	1319	470	49.105	1476	560	47.916	1759	640	48.459	2010	800	49.132	2513	900	49.835	2827	50	30	1500		
		880			984			1173			1340			1675			1885		20	1000		
		660			738			880			1005			1257			1414		15	750		
420	54.920	1187	470	54.353	1329	560	54.112	1583	640	53.638	1809	800	54.990	2262	900	56.576	2545	56	27	1500		
		787			881			1050			1200			1499			1687		17.9	1000		
		589			659			786			898			1123			1263		13.4	750		
420	61.654	1055	470	61.381	1181	560	60.747	1407	640	60.573	1608	800	62.021	2010	900	63.322	2262	63	24	1500		
		699			783			932			1066			1332			1498		15.9	1000		
		523			586			698			797			997			1121		11.9	750		
420	69.806	924	470	68.908	1034	560	68.780	1231	640	68.001	1407	800	70.735	1759	900	71.418	1979	71	21	1500		
		620			694			827			945			1181			1329		14.1	1000		
		466			522			622			710			888			999		10.6	750		
420	81.316	827	470	78.019	925	560	80.120	1102	640	76.992	1260	800	75.037	1575	900	81.452	1772	80	18.8	1500		
		550			615			733			838			1047			1178		12.5	1000		
		413			463			551			630			787			886		9.4	750		
410	86.427	717	470	90.882	822	560	85.156	979	640	89.687	1119	800	85.076	1399	900	86.407	1574	90	16.7	1500		
		477			546			651			744			930			1046		11.1	1000		
		356			408			487			556			695			782		8.3	750		
420	99.020	660	465	96.594	730	560	97.564	880	640	95.323	1005	800	100.783	1257	900	97.967	1414	100	15	1500		
		440			487			586			670			838			942		10	1000		
		330			365			440			503			628			707		7.5	750		
420	109.386	589	470	110.670	659	560	107.778	786	640	109.214	898	800	111.637	1123	900	116.054	1263	112	13.4	1500		
		391			438			522			596			746			839		8.9	1000		
		295			330			393			449			561			631		6.7	750		
420	121.182	528	470	122.255	591	560	119.400	704	640	120.647	804	800	124.041	1005	900	128.552	1131	125	12	1500		
		352			394			469			536			670			754		8	1000		
		264			295			352			402			503			565		6	750		
420	142.279	471	470	135.439	527	560	140.186	627	640	133.657	717	800	138.354	896	900	142.835	1008	140	10.7	1500		
		312			349			416			476			595			669		7.1	1000		
		237			266			317			362			452			509		5.4	750		
420	159.273	413	470	159.017	463	560	156.931	551	640	156.925	630	800	155.051	787	900	159.316	886	160	9.4	1500		
		277			310			369			422			528			594		6.3	1000		
		207			231			276			315			394			443		4.7	750		
420	172.632	365	470	178.011	408	560	170.093	487	640	175.669	556	800	169.982	695	900	178.544	782	180	8.3	1500		
		246			276			328			375			469			528		5.6	1000		
		185			207			264			281			352			396		4.2	750		
420	193.004	330	470	192.941	369	560	190.166	440	640	190.402	503	800	198.983	628	900	195.737	707	200	7.5	1500		
		220			246			293			335			419			471		5	1000		
		167			187			223			255			318			358		3.8	750		
420	217.257	295	470	215.711	330	560	214.062	393	640	212.872	449	800	222.710	561	900	229.132	631	224	6.7	1500		
		198			221			264			302			377			424		4.5	1000		
		145			162			194			221			276			311		3.3	750		
420	246.617	264	470	242.817	295	560	242.990	352	640	239.622	402	800	251.183	503	900	256.454	565	250	6	1500		
		176			197			235			268			355			377		4	1000		
		132			148			176			201			251			283		3	750		
420	271.278	237	470	275.630	266	560	267.289	317	640	272.004	362	800	271.709	452	900	289.241	509	280	5.4	1500		
		158			177			211			241			302			339		3.6	1000		
		119			133			158			181			226			254		2.7	750		
420	302.399	211	470	303.193	236	560	297.952	281	640	299.204	322	800	306.839	402	900	312.877	452	315	4.8	1500		
		141			157			188			214			268			302		3.2	1000		
		106			118			141			161			201			226		2.4	750		
410	340.720	180	470	337.975	207	560	335.710	246	640	333.528	281	800	352.538	352	900	353.329	396	355	4.2	1500		
		120			138			164			188			235			264		2.8	1000		
		90			103			123			141			176			198		2.1	750		
			465	380.805	185				640	375.794	255				900	405.953	358	400	3.8	1500		
					122						168						236		2.5	1000		
					93						127						179		1.9	750		
																		450	3.3	1500		
																					2.2	1000
																					1.7	750

B系列传动能力表(i=5-28):

B series transmission capacity table(i=5-28):

n ₁ (r/min)	n _{2N} (r/min)	i _N	B-4			B-5			B-6			B-7			B-8			B-9							
			T _{2N} (kN·m)	i _{ex}	P _{1N} (kW)	T _{2N} (kN·m)	i _{ex}	P _{1N} (kW)	T _{2N} (kN·m)	i _{ex}	P _{1N} (kW)	T _{2N} (kN·m)	i _{ex}	P _{1N} (kW)	T _{2N} (kN·m)	i _{ex}	P _{1N} (kW)	T _{2N} (kN·m)	i _{ex}	P _{1N} (kW)					
1500	300	5	5.8	4.936	182	9.4	5.006														28	5.002	880		
1000	200				121																		197	586	
750	150				91																		148	440	
1500	268	5.6	5.8	5.480	163	9.4	5.488															28	5.483	786	
1000	179				109																			176	525
750	134				81																			132	393
1500	238	6.3	5.8	6.296	145	9.4	6.386	12	6.205	200	17.8	6.206	299	444	22.3	6.135	371	556	28	6.381	28	6.381	698		
1000	159				97																		157	466	
750	119				72																		117	349	
1500	211	7.1	5.8	6.959	128	9.4	7.058	12	6.802	177	17.8	6.860	265	393	22.3	6.725	329	493	28	7.053	28	7.053	619		
1000	141				86																		139	413	
750	106				64																		104	311	
1500	188	8	5.8	7.549	114	9.4	7.657	12	7.915	157	17.8	7.880	236	350	22.3	7.825	292	439	28	8.101	28	8.101	551		
1000	125				76																		123	366	
750	94				57																		93	276	
1500	167	9	5.8	8.693	101	9.4	8.817	12	8.749	139	17.8	8.569	210	311	22.3	8.649	259	390	28	8.810	28	8.810	490		
1000	111				67																		109	325	
750	83				50																		82	243	
1500	150	10	5.8	9.872	91	9.4	10.108	12	9.490	126	17.8	9.823	188	280	22.3	9.935	234	350	28	10.099	28	10.099	440		
1000	100				61																		98	293	
750	75				46																		74	220	
1500	134	11.2	5.8	10.769	81	9.4	10.923	12	10.928	112	17.8	10.615	168	250	22.3	10.804	208	313	28	10.914	28	10.914	393		
1000	89				54																		88	261	
750	67				41																		66	196	
1500	120	12.5	5.5	12.034	69	9.4	12.703	12	12.528	101	17.0	12.433	151	214	22.3	12.385	187	280	28	12.554	28	12.554	352		
1000	80				46																		79	235	
750	60				35																		59	176	
1500	107	14	6	13.484	67	9.8	13.964	12	13.538	89	18.2	13.515	134	204	22.3	13.385	166	250	29.5	14.137	29.5	14.137	331		
1000	71				45																		73	219	
750	54				34																		55	167	
1500	94	16	6.2	15.601	61	10.2	15.835	12	15.826	79	19.1	16.275	118	188	21.5	15.773	142	212	31	15.952	31	15.952	305		
1000	63				41																		67	205	
750	47				31																		50	153	
1500	83	18	6.4	17.482	56	10.6	17.407	12.6	17.307	74	19.8	17.692	110	172	23.1	17.041	135	201	32.5	17.963	32.5	17.963	282		
1000	56				38																		62	191	
750	42				28																		47	143	
1500	75	20	6.6	19.614	52	11	19.645	13.2	19.729	69	20.5	19.948	104	161	23.9	20.648	125	188	34	20.259	34	20.259	267		
1000	50				35																		58	178	
750	38				26																		44	135	
1500	67	22.4	6.6	21.919	46	11	21.954	13.8	21.575	65	20.5	22.146	97	144	24.8	22.308	117	174	34	22.208	34	22.208	239		
1000	45				31																		52	160	
750	33				23																		38	117	
1500	60	25	6.6	25.380	41	11	25.421	14.5	24.349	61	20.5	25.446	91	129	25.5	25.152	107	160	34	25.843	34	25.843	214		
1000	40				28																		46	142	
750	30				21																		35	107	
1500	54	28	6.6	27.836	37	11	27.881	14.5	27.211	55	20.5	28.125	82	116	25.5	27.923	96	144	34	28.563	34	28.563	192		
1000	36				25																		41	128	
750	27				19																		31	96	

B-10			B-11			B-12			B-13			B-14			B-15			i_N	n_{2N} (r/min)	n_1 (r/min)
T_{2N} (kN·m)	i_{ex}	P_{1N} (kW)	T_{2N} (kN·m)	i_{ex}	P_{1N} (kW)	T_{2N} (kN·m)	i_{ex}	P_{1N} (kW)	T_{2N} (kN·m)	i_{ex}	P_{1N} (kW)	T_{2N} (kN·m)	i_{ex}	P_{1N} (kW)	T_{2N} (kN·m)	i_{ex}	P_{1N} (kW)			
					1351						2073							5	300	1500
			43	4.897	901				66	4.967	1382				122	4.963	2555	5	200	1000
					675						1037						1916	5	150	750
					1263						1880							5.6	268	1500
			45	5.534	843				67	5.613	1256				122	5.609	2287	5.6	179	1000
					631						940						1712	5.6	134	750
					1171						1769							6.3	238	1500
35.6	6.271	887			783	55	6.226	916	71	6.386	1182	82	6.156	2044				6.3	159	1000
		593	47	6.296	586			685			885			1022	130	6.340	1620	6.3	119	750
		444			1371						1769							6.3	238	1500
					783						1182							6.3	159	1000
					586						885							6.3	119	750
					1083						1613							7.1	211	1500
35.6	6.875	787			723	57	7.036	842	73	7.138	1078	84	6.957	1856				7.1	141	1000
		526	49	7.037	544			633			810			1240	132	7.132	1465	7.1	106	750
		395			994						1516			1732				8	188	1500
					661	59	8.005	772	77	8.108	1008	88	7.915	1152	132	8.101	1728	8	125	1000
					497						758			866				8	94	750
					883						1364							9	167	1500
35.6	8.842	623			587	61	8.947	709	78	8.817	907	91	8.847	1591				9	111	1000
		414	50.5	8.693	439			530			678			1058	132	8.810	1534	9	83	750
		309			793						1225			1492				10	150	1500
					529	62	10.164	649	78	10.108	817	95	10.049	995	132	10.099	1382	10	100	1000
					397			487			613			746				10	75	750
					709						1094							11.2	134	1500
35.6	11.045	500			471	62	11.052	578	78	10.923	727	97.5	10.928	1368				11.2	89	1000
		332	50.5	10.769	354			435			547			909	132	10.914	1230	11.2	67	750
		250			635						980			1225				12.5	120	1500
					423	62	12.670	519	78	12.482	653	97.5	12.528	817	132	12.172	1106	12.5	80	1000
					317			390			490			613				12.5	60	750
					594						896			1092				14	107	1500
35.6	13.683	399			394	62	13.692	461	80	13.721	595	97.5	13.538	725	137	13.810	1019	14	71	1000
		265	53	13.821	300			351			452			551				14	54	750
		201			551						817			960				16	94	1500
35.6	15.693	350			369	62	15.888	409	83	16.354	548	97.5	15.552	643	142	15.215	937	16	63	1000
		235	56	15.522	276			305			408			480				16	47	750
		175			504						739			869				18	83	1500
					340	65	17.572	381	85	17.978	498	100	17.007	586	148	17.262	868	18	56	1000
					255			286			374			440				18	42	750
					471						691			809				20	75	1500
					314	68	19.995	356	88	20.276	461	103	20.376	539	153	19.379	801	20	50	1000
					239			271			350			410				20	38	750
					421						617			744				22.4	67	1500
41	22.520	309			283	72	22.114	339	88	22.226	415	106	22.282	499	153	21.900	721	22.4	45	1000
		206	60	19.744	207			249			304			366				22.4	33	750
		156			471						553			685				25	60	1500
					251	75	25.103	314	88	25.864	369	109	25.131	457	153	24.916	641	25	40	1000
					188			236			276			342				25	30	750
					339						498			616				28	54	1500
43	25.400	270			226	75	27.517	283	88	28.587	332	109	27.548	411	153	27.847	577	28	36	1000
		180	60	25.185	170			212			249			308				28	27	750
		135			424						498			616				28	36	1000
					226	75	27.517	283	88	28.587	332	109	27.548	411	153	27.847	577	28	36	1000
					170			212			249			308				28	27	750

注: 卧式安装齿轮箱要求采用强制润滑。

Note: Forced lubrication required on horizontal gear units.

B系列传动能力表(i=5-28):

(续前页)

B series transmission capacity table(i=5-28):

n ₁ (r/min)	n _{2N} (r/min)	i _N	B-16			B-17			B-18			B-19			B-20			B-21			
			T _{2N} (kN·m)	i _{ex}	P _{1N} (kW)	T _{2N} (kN·m)	i _{ex}	P _{1N} (kW)	T _{2N} (kN·m)	i _{ex}	P _{1N} (kW)	T _{2N} (kN·m)	i _{ex}	P _{1N} (kW)	T _{2N} (kN·m)	i _{ex}	P _{1N} (kW)	T _{2N} (kN·m)	i _{ex}	P _{1N} (kW)	
1500	300	5																			
1000	200																				
750	150																				
1500	268	5.6																			
1000	179		135	5.630		195	5.514														
750	134				1894			2736													
1500	238	6.3																			
1000	159		141	6.362	2348	195	6.234														
750	119				1757			2430													
1500	211	7.1																			
1000	141		145	7.192	2141	195	7.012	2879	230	7.239											
750	106				1609			2164			2553										
1500	188	8																			
1000	125		148	8.090	1937	195	7.965	2552	230	8.143											
750	94				1457			1919			2264										
1500	167	9			2588																
1000	111		148	9.190	1720	195	8.662	2266	230	9.250	2673										
750	83				1286			1695			1999										
1500	150	10			2325																
1000	100		148	9.993	1550	195	9.930	2042	230	10.059	2408										
750	75				1162			1531			1806										
1500	134	11.2			2077																
1000	89		148	11.456	1379	195	10.731	1817	230	11.531	2143										
750	67				1038			1368			1614										
1500	120	12.5			1860			2450													
1000	80		148	12.380	1240	195	12.770	1634	230	12.462	1927	250	12.062	2094				340	12.256	2848	
750	60				930			1225			1445			1571						2136	
1500	107	14			1658			2185													
1000	71		148	13.832	1100	195	13.790	1450	230	14.654	1710	262	13.709	1948	295	13.698	2193	360	13.902	2676	
750	54				837			1103			1301			1481			1668			2036	
1500	94	16			1516			1969													
1000	63		154	15.665	1016	200	16.226	1319	230	16.014	1517	275	15.192	1814	308	15.640	2032	380	15.436	2507	
750	47				758			984			132			1353			1516			1870	
1500	83	18			1391			1738													
1000	56		160	17.290	938	200	17.522	1173	240	18.620	1407	288	17.267	1689	320	17.252	1876	400	17.510	2346	
750	42				704			880			1055			1267			1407			1759	
1500	75	20			1312			1571													
1000	50		167	19.581	874	200	19.762	1047	240	20.348	1257	300	19.607	1571	332	19.698	1738	420	19.883	2199	
750	38				665			796			955			1194			1321			1671	
1500	67	22.4			1214			1403													
1000	45		173	21.982	815	200	22.333	942	240	22.950	1311	300	22.158	1414	345	22.368	1626	420	22.470	1979	
750	33				598			691			829			1037			1192			1451	
1500	60	25			1087			1257													
1000	40		173	24.842	725	200	25.409	838	240	25.936	1005	300	25.048	1257	345	25.278	1445	420	25.400	1759	
750	30				543			628			754			942			1084			1319	
1500	54	28			978			1131													
1000	36		173	28.263	652	200	28.398	754	240	29.507	905	300	28.175	1131	345	28.576	1301	420	28.571	1583	
750	27				489			565			679			848			975			1187	

注: 卧式安装齿轮箱要求采用强制润滑。

Note: Forced lubrication required on horizontal gear units.

B-22			B-23			B-24			B-25			B-26			i _N	n _{2N} (r/min)	n ₁ (r/min)
T _{2N} (kN·m)	i _{ex}	P _{1N} (kW)	T _{2N} (kN·m)	i _{ex}	P _{1N} (kW)	T _{2N} (kN·m)	i _{ex}	P _{1N} (kW)	T _{2N} (kN·m)	i _{ex}	P _{1N} (kW)	T _{2N} (kN·m)	i _{ex}	P _{1N} (kW)			
															5	300	1500
																200	1000
																150	750
															5.6	268	1500
																179	1000
																134	750
															6.3	238	1500
																159	1000
																119	750
															7.1	211	1500
																141	1000
																106	750
															8	188	1500
																125	1000
																94	750
															9	167	1500
																111	1000
																83	750
															10	150	1500
																100	1000
																75	750
															11.2	134	1500
																89	1000
																67	750
															12.5	120	1500
																80	1000
																60	750
405	13.719														14	107	1500
		2299														71	1000
																54	750
422	15.538														16	94	1500
		2784														63	1000
		2077														47	750
438	17.279														18	83	1500
		2568														56	1000
		1926														42	750
455	19.570		560	19.591											20	75	1500
		2382			2932											50	1000
		1810			2228											38	750
470	22.222		560	22.139		640	21.930	3015	800	21.793				22.4	67	1500	
		2215			2639			2212								45	1000
		1624			1935						2764					33	750
470	25.113		560	25.027		640	24.783	2681	800	24.635		900	25.095	25	60	1500	
		1969			2346			2010								40	1000
		1476			1759						2513		2827			30	750
470	28.389		560	28.151		640	28.015	2413	800	27.711		900	28.368	28	54	1500	
		1772			2111			1809								36	1000
		1329			1583						3016		2545			27	750
											2262						

注：□ 卧式安装齿轮箱要求采用强制润滑。

Note: □ Forced lubrication required on horizontal gear units.

B系列传动能力表(i=31.5-400):

B series transmission capacity table(i=31.5-400):

n ₁ (r/min)	n _{2N} (r/min)	i _N	B-4			B-5			B-6			B-7			B-8			B-9												
			T _{2N} (kN·m)	i _{ex}	P _{1N} (kW)	T _{2N} (kN·m)	i _{ex}	P _{1N} (kW)	T _{2N} (kN·m)	i _{ex}	P _{1N} (kW)	T _{2N} (kN·m)	i _{ex}	P _{1N} (kW)	T _{2N} (kN·m)	i _{ex}	P _{1N} (kW)	T _{2N} (kN·m)	i _{ex}	P _{1N} (kW)										
1500	48	31.5	6.6	30.196	33	11	30.245	14.5	31.508	73	20.5	30.509	103	25.5	32.084	128	34	30.985	171											
1000	32				22					37			49			69			85	114										
750	24				17					28			36			52			64	85										
1500	42	35.5	6.6	34.771	29	11	34.827	14.5	34.557	64	20.5	35.131	90	25.5	35.461	112	34	35.679	150											
1000	28				19					32			43			60			75	100										
750	21				15					24			32			45			56	75										
1500	38	40	6.6	39.487	26	11	39.551	14.5	37.486	58	20.5	39.896	82	25.5	38.468	101	34	40.902	135											
1000	25				17					29			38			54			67	89										
750	18.8				13					22			29			40			50	67										
1500	33	45	6.6	43.077	23	11	43.146	14.5	43.166	50	20.5	43.523	71	25.5	44.296	88	34	44.202	117											
1000	22				15					25			33			47			59	78										
750	16.7				12					19			25			36			45	59										
1500	30	50	6.6	49.060	21	11	49.139	14.5	49.021	46	20.5	49.568	64	25.5	50.304	80	34	50.341	107											
1000	20				14					23			30			43			53	71										
750	15				10.4					17			23			32			40	53										
1500	27	56	6.6	55.152	19	11	55.240	14.5	53.477	41	20.5	55.723	58	25.5	54.877	72	34	56.592	96											
1000	17.9				12					21			27			38			48	64										
750	13.4				9.3					15			20			29			36	48										
1500	24	63	6.6	60.808	17	11	60.906	14.5	60.904	36	20	61.438	50	25.5	62.499	64	34	62.396	85											
1000	15.9				11					18			24			33			42	57										
750	11.9				8.2					14			18			25			32	42										
1500	21	71	6.6	69.293	14.5	11	69.404	14.5	68.467	32	20	70.011	44	25.5	70.259	56	34	71.102	75											
1000	14.1				9.7					16			21			30			38	50										
750	10.6				7.3					12			16			22			28	38										
1500	18.8	80				11	77.598	14	75.489	22	20.5	79.267	40	25.2	77.465	50	34	79.497	67											
1000	12.5																													45
750	9.4																													33
1500	16.7	90				11	86.720	14	86.022	19	20.5	88.585	24	25.2	88.274	36	34	88.842	59											
1000	11.1																													40
750	8.3																													30
1500	15	100				11	100.413	14.5	96.178	17.3	20.5	102.572	32	25.5	99.945	40	34	102.869	53											
1000	10																													36
750	7.5																													27
1500	13.4	112				11	110.130	14.5	107.484	15	20.5	112.498	20	25.5	111.694	36	34	112.824	48											
1000	8.9																													32
750	6.7																													24
1500	12	125				11	119.446	14.5	124.455	14	20.5	122.035	18	25.5	129.330	32	34	122.389	43											
1000	8																													28
750	6																													21
1500	10.7	140				11	137.567	14.5	136.499	12	20.5	140.525	23	25.5	141.846	32	34	140.933	38											
1000	7.1																													25
750	5.4																													19
1500	9.4	160				11	156.225	14.5	148.071	11	20.5	159.585	20	25.5	153.871	32	34	160.047	33											
1000	6.3																													22
750	4.7																													17
1500	8.3	180				11	170.427	14.5	170.506	9.6	20.5	174.092	13	25.5	177.184	32	34	174.597	30											
1000	5.6																													20
750	4.2																													15
1500	7.5	200				11	194.098	14.5	193.631	8.6	20.5	198.272	11.4	25.5	201.215	20	34	198.847	27											
1000	5																													18
750	3.8																													14
1500	6.7	224				11	218.199	14.5	211.234	7.7	20.5	222.891	10	25.5	219.508	14.4	34	223.537	24											
1000	4.5																													16
750	3.3																													12
1500	6	250				11	240.578	14.5	240.572	6.9	20.5	245.752	9.1	25.5	249.995	16	34	246.464	21											
1000	4																													14
750	3																													11
1500	5.4	280				11	274.147	14.5	270.443	6.2	20.5	280.042	12	25.5	281.036	14.4	34	280.855	19											
1000	3.6																													13
750	2.7																													10
1500	4.8	315				11	302.121	14.5	298.181	5.5	20.5	308.618	7.3	25.5	309.861	10.3	34	309.513	17											
1000	3.2																													11
750	2.4																													8.5
1500	4.2	355				11	339.788	14.5	339.788	6.4	20.5	339.788	10.3	25.5	353.097	11.2	34	353.097	17											
1000	2.8																													11
750	2.1																													8.5
1500	3.8	400				11	374.460	14.5	374.460	5.8	20.5	374.460	10	25.5	389.127	10	34	389.127	17											
1000	2.5																													11
750	1.5																													8.5

B-10			B-11			B-12			B-13			B-14			B-15			i _N	n _{2N} (r/min)	n ₁ (r/min)
T _{2N} (kN·m)	i _{ex}	P _{1N} (kW)	T _{2N} (kN·m)	i _{ex}	P _{1N} (kW)	T _{2N} (kN·m)	i _{ex}	P _{1N} (kW)	T _{2N} (kN·m)	i _{ex}	P _{1N} (kW)	T _{2N} (kN·m)	i _{ex}	P _{1N} (kW)	T _{2N} (kN·m)	i _{ex}	P _{1N} (kW)			
43	32.400	216	60	31.975	302	75	32.021	377	88	32.838	442	109	32.057	548	153	31.634	769	31.5	48	1500
		144			201			251			295			365			513		32	1000
		108			151			188			221			274			385		24	750
43	35.811	189	60	34.771	264	75	35.392	330	88	35.709	387	109	35.432	479	153	34.400	673	35.5	42	1500
		126			176			220			258			320			449		28	1000
		95			132			165			194			240			336		21	750
43	38.846	171	60	39.861	239	75	40.654	298	88	40.936	350	109	40.700	434	153	39.435	609	40	38	1500
		113			157			196			230			285			401		25	1000
		85			118			148			173			215			301		18.8	750
43	44.732	149	60	43.077	207	75	44.209	259	88	44.238	304	109	44.259	377	153	42.617	529	45	33	1500
		99			138			173			203			251			352		22	1000
		75			105			131			154			191			268		16.7	750
43	51.280	135	60	49.060	188	75	50.681	236	88	50.383	276	109	50.737	342	153	48.536	481	50	30	1500
		90			126			157			184			228			320		20	1000
		68			94			118			138			171			240		15	750
43	55.417	122	60	55.152	170	75	54.769	212	88	56.639	249	109	54.831	308	153	54.562	433	56	27	1500
		81			112			141			165			204			287		17.9	1000
		60			84			105			123			153			215		13.4	750
43	63.114	108	60	60.808	151	75	62.376	188	88	62.448	221	109	62.446	274	153	60.158	385	63	24	1500
		72			100			125			147			181			255		15.9	1000
		54			75			93			110			136			191		11.9	750
43	70.951	95	60	69.293	132	75	70.121	165	88	71.161	194	109	70.200	240	153	68.553	336	71	21	1500
		63			89			111			130			161			226		14.1	1000
		48			67			83			98			121			170		10.6	750
43	78.228	85	60	80.949	118	75	77.313	148	88	82.118	173	109	77.400	215	153	78.131	301	80	18.8	1500
		56			79			98			115			143			200		12.5	1000
		42			59			74			87			107			151		9.4	750
43	89.143	75	60	89.869	105	75	88.101	131	88	90.016	154	109	88.200	191	153	85.645	268	90	16.7	1500
		50			70			87			102			127			178		11.1	1000
		37			52			65			76			95			133		8.3	750
43	99.667	68	60	103.259	94	75	102.921	118	88	104.750	138	109	101.780	171	153	99.664	240	100	15	1500
		45			63			79			92			114			160		10	1000
		34			47			59			69			86			120		7.5	750
43	111.384	60	60	114.129	84	75	114.262	105	88	115.777	123	109	111.569	153	153	110.155	215	112	13.4	1500
		40			56			70			82			102			143		8.9	1000
		30			42			53			62			76			107		6.7	750
43	128.971	54	60	123.804	75	75	131.287	94	88	125.592	111	109	129.831	137	153	126.535	192	125	12	1500
		36			50			63			74			91			128		8	1000
		27			38			47			55			68			96		6	750
43	141.452	48	60	142.562	67	75	145.106	84	88	144.621	99	109	143.498	122	153	137.599	171	140	10.7	1500
		32			45			56			65			81			114		7.1	1000
		24			34			42			50			62			87		5.4	750
43	153.443	42	60	161.897	59	75	157.408	74	88	165.791	87	109	155.663	107	153	157.741	151	160	9.4	1500
		28			40			49			58			72			101		6.3	1000
		21			30			37			43			54			75		4.7	750
43	176.692	37	60	176.615	52	75	181.258	65	88	179.166	76	109	179.248	95	153	170.467	133	180	8.3	1500
		25			35			44			52			64			90		5.6	1000
		19			26			33			39			48			67		4.2	750
43	200.656	34	60	201.145	47	75	205.841	59	88	204.050	69	109	205.487	86	153	194.143	120	200	7.5	1500
		23			31			39			46			57			80		5	1000
		17			24			30			35			43			61		3.8	750
43	218.898	30	60	226.121	42	75	224.554	53	88	229.386	62	109	222.065	76	153	218.249	107	224	6.7	1500
		20			28			35			41			51			72		4.5	1000
		15			21			26			30			38			53		3.3	750
43	249.300	27	60	249.313	38	75	255.742	47	88	252.913	55	109	252.907	68	153	240.634	96	250	6	1500
		18			25			31			37			46			64		4	1000
		14			19			24			28			34			48		3	750
43	280.256	24	60	284.101	34	75	287.497	42	88	288.204	50	109	284.310	62	153	274.210	87	280	5.4	1500
		16			23			28			33			41			58		3.6	1000
		12			17			21			25			31			43		2.7	750
43	309.000	22	60	313.091	30	75	316.984	38	88	317.612	44	109	313.470	55	153	302.191	77	315	4.8	1500
		14			20			25			29			37			51		3.2	1000
		11			15.1			19			22			27			38		2.4	750
43	352.116	19	60	361.214	33	75	361.214	44	88	361.214	55	109	357.210	77	153	352.116	96	355	4.2	1500
		13			22			28			32			40			58		2.8	1000
		9.5			16			20			24			30			38		2.1	750
43	388.046	17	60	398.073	30	75	398.073	44	88	398.073	55	109	393.660	77	153	388.046	96	400	3.8	1500
		11.3			20			25			29			37			51		2.5	1000
		8.6			15			19			22			27			38		1.5	750

B系列传动能力表(i=31.5-400):

(续前页)

B series transmission capacity table(i=31.5-400):

n ₁ (r/min)	n _{2N} (r/min)	i _N	B-16			B-17			B-18			B-19			B-20			B-21														
			T _{2N} (kN·m)	i _{ex}	P _{1N} (kW)	T _{2N} (kN·m)	i _{ex}	P _{1N} (kW)	T _{2N} (kN·m)	i _{ex}	P _{1N} (kW)	T _{2N} (kN·m)	i _{ex}	P _{1N} (kW)	T _{2N} (kN·m)	i _{ex}	P _{1N} (kW)	T _{2N} (kN·m)	i _{ex}	P _{1N} (kW)												
1500	48	31.5	173	31.588	870	200	32.259	240	32.979	1206	300	32.005	1508	345	32.143	1734	420	32.456	2111													
1000	32				580					670			804			1005			1156	1407												
750	24				435					503			603			754			867	1055												
1500	42	35.5	173	35.883	761	200	35.080	240	37.463	1055	300	34.804	1319	345	36.513	1517	420	35.294	1847													
1000	28				507					586			704			880			1012	1231												
750	21				380					440			528			660			759	924												
1500	38	40	173	39.021	688	200	40.215	240	40.738	955	300	39.899	1194	345	39.706	1373	420	40.461	1671													
1000	25				453					524			628			785			903	1099												
750	18.8				341					394			472			591			679	827												
1500	33	45	173	44.732	598	200	43.460	240	46.702	829	300	43.117	1037	345	45.518	1192	420	43.725	1451													
1000	22				399					461			553			691			795	968												
750	16.7				303					350			420			525			603	734												
1500	30	50	173	48.341	543	200	49.496	240	50.469	754	300	49.106	942	345	49.190	1083	420	49.798	1319													
1000	20				362					419			503			628			723	880												
750	15				272					314			377			471			542	660												
1500	27	56	173	55.055	489	200	55.641	240	57.479	679	300	55.203	848	345	56.022	975	420	55.981	1187													
1000	17.9				324					375			450			562			647	787												
750	13.4				243					281			337			421			484	589												
1500	24	63	173	61.892	435	200	61.348	240	64.616	603	300	60.865	754	345	62.978	867	420	61.722	1055													
1000	15.9				288					333			400			499			574	699												
750	11.9				216					249			299			374			430	523												
1500	21	71	173	68.239	380	200	69.909	240	71.243	528	300	69.358	660	345	69.438	759	420	70.335	924													
1000	14.1				255					295			354			443			509	620												
750	10.6				192					222			266			333			383	466												
1500	18.8	80	173	77.761	341	200	76.506	240	81.184	472	300	79.977	591	345	79.127	679	420	77.639	827													
1000	12.5				226					262			314			393			452	550												
750	9.4				170					197			236			295			340	413												
1500	16.7	90	173	88.626	303	200	83.865	240	88.846	420	300	87.670	525	345	91.242	603	420	87.739	734													
1000	11.1				201					232			279			349			401	488												
750	8.3				150					174			209			261			300	365												
1500	15	100	173	97.150	272	200	97.593	240	97.391	377	300	102.020	471	345	100.017	542	420	99.821	660													
1000	10				181					209			251			314			361	440												
750	7.5				136					157			188			236			271	330												
1500	13.4	112	173	113.052	243	200	107.865	240	13.333	337	300	112.759	421	345	116.389	484	420	111.565	589													
1000	8.9				161					186			224			280			322	391												
750	6.7				121					140			168			210			242	295												
1500	12	125	173	124.952	217	200	123.904	240	125.263	302	300	129.526	377	345	128.641	434	420	126.733	528													
1000	8				145					168			201			251			289	352												
750	6				109					126			151			188			217	264												
1500	10.7	140	173	143.532	194	200	134.739	240	143.889	269	300	140.851	336	345	147.769	387	420	137.815	471													
1000	7.1				129					149			178			223			256	312												
750	5.4				98					113			136			170			195	237												
1500	9.4	160	173	156.082	170	200	154.462	240	156.471	236	300	161.470	295	345	160.690	340	420	157.989	413													
1000	6.3				114					132			158			198			228	277												
750	4.7				85					98			118			148			170	207												
1500	8.3	180	173	178.930	150	200	166.923	240	179.375	209	300	174.496	261	345	184.212	300	420	170.735	365													
1000	5.6				101					117			141			176			202	246												
750	4.2				76					88			106			132			152	185												
1500	7.5	200	173	193.365	136	200	190.107	240	193.846	188	300	198.732	236	345	199.073	271	420	194.448	330													
1000	5				91					105			126			157			181	220												
750	3.8				69					80			95			119			137	167												
1500	6.7	224	173	220.222	121	200	213.712	240	220.769	168	300	223.408	210	345	226.722	242	420	218.592	295													
1000	4.5				82					94			113			141			163	198												
750	3.3				60					69			83			104			119	145												
1500	6	250	173	247.566	109	200	235.631	240	248.182	151	300	246.322	188	345	254.874	217	420	241.012	264													
1000	4				72					84			101			126			145	176												
750	3				54					63			75			94			108	132												
1500	5.4	280	173	272.957	98	200	268.510	240	273.636	136	300	280.692	170	345	281.015	195	420	274.641	237													
1000	3.6				65					75			90			113			130	158												
750	2.7				49					57			68			85			98	119												
1500	4.8	315	173	311.045	87	200	295.909	240	311.818	121	300	309.334	151	345	320.226	173	420	302.666	211													
1000	3.2				58					67			80			101			116	141												
750	2.4				43					50			60			75			87	106												
1500	4.2	355	173	342.784	76	200	343.636	240	343.636	106	300	343.636	152	345	352.902	173	420	343.636	211													
1000	2.8				51					70			85			101			116	141												
750	2.1				38					53			63			76			87	106												
1500	3.8	400																														
1000	2.5																															
750	1.5																															

注: 卧式安装齿轮箱要求采用强制润滑。

Note: Forced lubrication required on horizontal gear units.

B-22			B-23			B-24			B-25			B-26			i _N	n _{2N} (r/min)	n ₁ (r/min)	
T _{2N} (kN·m)	i _{ex}	P _{1N} (kW)	T _{2N} (kN·m)	i _{ex}	P _{1N} (kW)	T _{2N} (kN·m)	i _{ex}	P _{1N} (kW)	T _{2N} (kN·m)	i _{ex}	P _{1N} (kW)	T _{2N} (kN·m)	i _{ex}	P _{1N} (kW)				
470	31.933	1575	560	31.979	1876	640	31.513	2145	800	31.478	2681	900	31.909	3016	31.5	48	1500	
		181			1407			1608			2010			2262	32	1000		
		2067			2463			2815							24	750		
470	36.275	1378	560	34.775	1642	640	35.797	1876	800	34.231	2346	900	36.248	2639	35.5	42	1500	
		1034			1231			1407			1759			1979	28	1000		
		1870			2228			2597							21	750		
470	39.446	1230	560	39.866	1466	640	38.927	1675	800	39.241	2094	900	39.417	2356	40	38	1500	
		925			1102			1260			1575			1772	25	1000		
		1624			1935			2212			2764				18.8	750		
470	45.221	1083	560	43.082	1290	640	44.626	1474	800	42.407	1843	900	45.187	2073	45	33	1500	
		822			979			1119			1399			1574	22	1000		
		1476			1759			2010			2513			2827	16.7	750		
470	48.869	984	560	49.065	1173	640	48.226	1340	800	48.297	1675	900	48.833	1885	50	30	1500	
		738			880			1005			1257			1414	20	1000		
		1329			1583			1809			2262			2545	15	750		
470	55.656	881	560	55.158	1050	640	54.924	1200	800	54.294	1499	900	55.615	1687	56	27	1500	
		659			786			898			1123			1263	17.9	1000		
		1181			1407			1608			2010			2262	13.4	750		
470	62.567	783	560	60.815	932	640	61.744	1066	800	59.863	1332	900	62.520	1498	63	24	1500	
		586			698			797			997			1121	15.9	1000		
		1034			1231			1407			1759			1979	11.9	750		
470	68.984	694	560	69.301	827	640	68.076	945	800	68.216	1181	900	68.933	1329	71	21	1500	
		522			622			710			888			999	14.1	1000		
		925			1102			1260			1575			1772	10.6	750		
470	78.610	615	560	76.497	733	640	77.575	838	800	78.100	1047	900	78.551	1178	80	18.8	1500	
		463			551			630			787			886	12.5	1000		
		822			979			1119			1399			1574	9.4	750		
470	86.772	546	560	86.448	651	640	85.631	744	800	88.260	930	900	89.933	1046	90	16.7	1500	
		408			487			556			695			782	11.1	1000		
		738			880			1005			1257			1414	8.3	750		
470	98.061	492	560	98.353	586	640	96.770	670	800	100.414	838	900	101.633	942	100	15	1500	
		369			440			503			628			707	10	1000		
		659			786			898			1123			1263	7.5	750		
470	111.565	438	560	109.924	522	640	110.097	596	800	112.228	746	900	115.629	839	112	13.4	1500	
		330			393			449			561			631	8.9	1000		
		591			704			804			1005			1131	6.7	750		
470	124.690	394	560	124.870	469	640	123.049	536	800	127.487	670	900	129.232	754	125	12	1500	
		295			352			402			503			565	8	1000		
		527			627			717			896			1008	6	750		
470	141.643	349	560	135.788	416	640	139.780	476	800	138.634	595	900	146.803	669	140	10.7	1500	
		266			317			362			452			509	7.1	1000		
		463			551			630			787			886	5.4	750		
470	154.029	310	560	155.665	369	640	152.002	422	800	158.928	528	900	159.639	594	160	9.4	1500	
		231			276			315			394			443	6.3	1000		
		408			487			556			695			782	4.7	750		
470	176.576	276	560	168.224	328	640	174.252	375	800	171.749	469	900	183.008	528	180	8.3	1500	
		207			246			281			352			396	5.6	1000		
		369			440			503			628			707	4.2	750		
470	190.821	246	560	191.588	293	640	188.310	335	800	195.603	419	900	197.772	471	200	7.5	1500	
		187			223			255			318			358	5	1000		
		330			393			449			561			631	3.8	750		
470	217.324	221	560	215.377	264	640	214.464	302	800	219.891	377	900	225.240	424	224	6.7	1500	
		162			194			221			276			311	4.5	1000		
		295			352			402			503			565	3.3	750		
470	244.309	197	560	237.467	235	640	241.094	268	800	242.444	335	900	253.208	377	250	6	1500	
		148			176			201			251			283	4	1000		
		266			317			362			452			509	3	750		
470	269.366	177	560	270.602	211	640	265.822	241	800	276.274	302	900	279.178	339	280	5.4	1500	
		133			158			181			226			254	3.6	1000		
		236			281			322			402			452	2.7	750		
470	306.952	157	560	298.215	188	640	302.913	214	800	304.465	268	900	318.133	302	315	4.8	1500	
		118			141			161			201			226	3.2	1000		
		207			281			322			402			452	2.4	750		
470	338.273	138	560	333.823	188	640	333.823	214	800	304.465	268	900	318.133	302	355	4.2	1500	
		103			141			161			201			226	2.8	1000		
		207			281			322			402			452	2.1	750		
															400	3.8	1500	
																	2.5	1000
																	1.5	750

注: 卧式安装齿轮箱要求采用强制润滑。

Note: Forced lubrication required on horizontal gear units.

H系列额定热容量(kW):

H series rated thermal capacities(kW):

iN		H1-3	H1-5	H1-7	H1-9	H1-11	H1-13	H1-15	H1-17	H1-19
1.25	PG1	110	207	230	190					
	PG2	171	408	562	642					
	PG3	268	641	923	1322					
	PG4	322	819	1177	1621					
1.4	PG1	110	214	250	247					
	PG2	169	409	567	670					
	PG3	260	629	901	1305					
	PG4	312	800	1149	1589					
1.6	PG1	108	215	261	303	234				
	PG2	164	399	548	686	967	891			
	PG3	244	593	836	1246	2138	2631			
	PG4	295	754	1064	1519	2632	3220			
1.8	PG1	120	214	274	323	330				
	PG2	181	387	552	682	1000	1011			
	PG3	264	557	818	1195	2082	2547			
	PG4	319	712	1040	1454	2555	3095			
2	PG1	116	209	273	334	393	302			
	PG2	174	372	534	668	1010	1085	794		
	PG3	251	526	775	1135	2004	2483	2249		
	PG4	303	670	985	1382	2449	3001	3099		
2.24	PG1	112	202	263	335	433	416			
	PG2	166	353	496	643	999	1119	908		
	PG3	236	490	699	1063	1897	2377	2190		
	PG4	286	628	888	1296	2322	2874	2984		
2.5	PG1	103	192	252	328	452	486			
	PG2	153	332	466	611	971	1121	1001		
	PG3	212	453	644	984	1778	2246	2140		
	PG4	257	580	818	1201	2174	2714	2876		
2.8	PG1	97.0	180	263	347	456	525			
	PG2	143	309	477	630	928	1095	1063	884	
	PG3	195	413	649	990	1643	2091	2063	2359	
	PG4	237	529	824	1205	2010	2525	2744	3138	
3.15	PG1	95.1	185	293	371	520	620	464		
	PG2	138	305	535	664	976	1151	1291	1253	
	PG3	189	408	755	1075	1672	2082	2218	2585	
	PG4	227	517	967	1320	2030	2495	2847	3297	
3.55	PG1	87.5	182	272	349	493	607	527	420	
	PG2	126	297	490	616	902	1086	1259	1288	
	PG3	170	390	676	973	1508	1899	2057	2443	
	PG4	205	494	870	1198	1835	2277	2628	3088	
4	PG1	79.4	166	247	301	465	580	550	514	
	PG2	114	269	438	523	833	1006	1194	1267	1221
	PG3	151	346	592	806	1358	1171	1869	2249	
	PG4	182	439	763	998	1655	2055	2384	2829	
4.5	PG1	87.5	172	254	347	446	608	657	649	563
	PG2	122	272	437	585	789	1037	1273	1337	1351
	PG3	161	346	586	890	1290	1766	1905	2236	
	PG4	193	438	749	1093	1580	2126	2403	2782	
5	PG1	79.2	163	245	316	443	586	676	776	788
	PG2	111	257	419	527	770	989	1246	1495	1578
	PG3	143	325	551	783	1220	1662	1805	2414	
	PG4	172	411	707	964	1500	2003	2276	2988	
5.6	PG1	70.9	145	221	304	423	535	630	745	904
	PG2	98.3	227	374	503	730	890	1131	1374	1658
	PG3	125	281	483	729	1143	1457	1595	2148	
	PG4	150	357	621	902	1409	1761	2014	2660	

H系列额定热容量(kW):

H series rated thermal capacities(kW):

iN		4	5	6	7	8	9	10	11	12	13	14	15	16	17	18	19	20	21	22	23	24	25	26	
6.3	PG1	68.2	89.4		128		177		253		333		325		230		291								
	PG2	93.5	129		202		273		443		607		652		775										
	PG3	114	181		291		454		669		1164		1405		1713										
	PG4	137	218		357		539		835		1394		1653		2122										
7.1	PG1	69.9	91.1		124		173		256		340		351	342	315	260	375	321	372						
	PG2	95.7	131		194		264		440		601		659	672	807	802									
	PG3	115	180		273		427		650		1123		1358	1416	1658	1710									
	PG4	139	217		336		506		813		1344		1599	1670	2040	2129									
8	PG1	67.1	88.5	97.8	120	137	169	176	252	291	341	372	368	368	365	340	431	402	458	398					
	PG2	91.4	127	140	187	213	255	267	428	495	590	661	658	679	826	831									
	PG3	109	173	187	259	297	405	450	619	849	1069	1218	1310	1370	1611	1658									
	PG4	131	208	226	320	365	481	530	777	1023	1284	1468	1535	1614	1980	2042									
9	PG1	64.9	85.7	99.5	116	133	163	172	243	293	338	378	375	383	399	388	469	457	516	479	1037				
	PG2	88.2	123	141	180	204	245	257	406	491	573	652	647	676	829	848									
	PG3	104	165	187	246	280	383	421	572	824	1012	1175	1247	1321	1562	1615									
	PG4	126	198	225	302	344	456	496	717	994	1216	1407	1461	1550	1907	1983									
10	PG1	61.4	81.0	96.6	112	129	157	167	235	289	331	378	375	390	418	419	508	492	572	535	1076	1119			
	PG2	83.0	115	137	171	197	234	249	388	478	552	637	629	664	820	850									
	PG3	96.9	152	179	231	266	359	401	537	783	955	1116	1177	1254	1493	1556									
	PG4	117	183	215	285	327	428	472	672	950	1146	1343	1379	1475	1819	1908									
11.2	PG1	58.8	77.6	93.5	113	125	149	162	238	277	337	373	370	390	426	437	530	530	607	589	1118	1163			
	PG2	79.4	110	132	172	189	221	240	389	452	556	618	606	647	799	840									
	PG3	91.7	143	171	229	251	335	378	533	720	941	1062	1100	1187	1411	1494									
	PG4	111	173	206	283	310	400	447	668	872	1133	1275	1292	1391	1717	1822									
12.5	PG1	56.7	76.3	88.1	111	119	146	156	238	267	323	364	372	384	444	443	555	550	641	621	1118	1163	1337		
	PG2	75.7	107	124	167	180	215	229	381	430	523	595	600	622	799	817									
	PG3	88.5	141	157	224	237	324	356	522	675	863	997	1078	1114	1370	1410									
	PG4	106	169	190	275	292	384	421	650	818	1036	1199	1261	1305	1665	1716									
14	PG1	53.7	72.1	84.2	102	120	142	149	226	270	310	369	359	385	434	459	551	574	643	653	1110	1194	1327	1393	
	PG2	71.5	101	118	153	181	207	217	359	433	495	598	569	615	766	816									
	PG3	82.7	131	148	200	235	305	331	483	670	799	987	1001	1087	1280	1369									
	PG4	99.1	156	179	247	290	364	392	602	813	963	1187	1173	1276	1557	1665									
16	PG1	49.2	67.6	82.6	95.3	118	133	145	212	269	283	354	361	371	420	448	536	568	627	653	1084	1127	1296	1361	
	PG2	65.2	93.7	114	142	175	193	210	334	424	449	563	565	583	725	781									
	PG3	74.5	120	146	184	229	280	321	440	653	707	900	978	1009	1188	1281									
	PG4	89.6	144	175	226	282	334	378	549	789	855	1084	1147	1183	1444	1559									
18	PG1	47.0	64.5	78.1	91.1	108	125	140	196	255	285	338	340	373	415	433	534	551	617	637	1050	1092	1256	1318	
	PG2	62.0	89.4	108	136	160	181	202	310	398	450	533	527	579	702	739									
	PG3	70.0	113	135	175	206	261	302	410	602	709	836	901	987	1132	1185									
	PG4	84.2	136	163	216	253	312	357	513	729	854	1007	1059	1159	1373	1446									
20	PG1	46.0	60.4	73.1	84.9	102	121	132	189	238	267	308	326	351	406	429	517	548	598	634	1015	1056	1214	1274	
	PG2	60.4	83.5	100	126	149	174	189	297	369	419	482	498	540	681	717									
	PG3	67.7	105	124	160	189	250	278	387	547	646	740	828	910	1085	1124									
	PG4	81.4	126	150	198	232	298	329	484	663	780	893	970	1069	1318	1368									
22.4	PG1	42.5	56.1	69.8	81.8	97	111	124	176	220	240	310	330	336	355	420	440	531	524	607	775	1005	928	1210	
	PG2	55.8	77.1	95.8	121	143	161	177	275	343	301	482	443	510	460	695									
	PG3	61.7	95.4	118	153	180	225	259	352	512	525	740	844	834	844	1078									
	PG4	74.3	115	142	188	221	269	307	441	620	580	893	941	980	934	1311									
25	PG1		56.8	65.4	84.3	90.6	115	120	173	213	234	290	322	341	344	367	435	453	537	535	760	790	908	945	
	PG2		69.2	89.3	105	132	145	171	224	329	292	448	429	456	445	474									
	PG3		98.7	108	158	165	231	248	392	480	499	676	795	854	796	847									
	PG4		110	131	177	203	258	294	436	583	550	815	888	953	881	940									
28	PG1		54.5	60.7	84.7	87.1	114	111	167	198	225	259	318	333	339	355	427	447	540	548	778	809	930	967	
	PG2		66.5	82.6	106	127	143	158	215	304	281	323	421	441	436	456									
	PG3		93.2	98.8	157	157	224	224	367	435	468	548	767	804	766	799									
	PG4		104	119	176	193	250	267	410	530	518	605	858	898	850	887									
31.5	PG1		52.9	61.2	81.2	90.3	111	115	161	194	219	252	310	328	329	349	417	439	537	549	773	804	925	962	
	PG2		64.3	73.9	101	112	139	144	207	247	272	312	409	433	422	447									
	PG3		89.4	102	148	162	215	268	350	403	449	520													

H系列额定热容量(kW):

H series rated thermal capacities(kW):

iN		5	6	7	8	9	10	11	12	13	14	15	16	17	18	19	20	21	22	23	24	25	26
40	PG1	48.1	56.6	74.6	86.8	101	110	149	180	204	236	284	304	300	322	390	416	517	537	754	784	902	938
	PG2	58.3	68.6	92.8	107	127	137	190	228	251	291	371	398	382	409								
	PG3	79.3	92.4	132	151	191	248	312	359	403	467	639	686	641	683								
	PG4	88.6	103	149	170	214	272	349	402	446	517	717	770	711	760								
45	PG1	46.0	54.9	71.8	84.1	97.2	107	148	173	195	227	282	293	297	309	386	401	501	524	745	775	891	927
	PG2	55.7	66.2	89	104	121	133	189	219	240	280	368	381	377	392								
	PG3	74.9	88.3	126	145	181	238	305	341	379	444	626	648	627	644								
	PG4	83.8	98.7	142	163	203	261	342	382	419	491	702	725	695	716								
50	PG1	44.4	51.7	67.6	79.8	94.9	101	145	166	191	219	281	291	292	306	379	395	500	508	736	765	880	915
	PG2	53.6	62.2	83.7	98.0	118	125	184	210	233	269	362	378	368	386								
	PG3	72.3	82.0	118	136	177	221	299	322	369	419	619	634	613	628								
	PG4	80.9	91.7	133	152	197	242	334	360	408	465	691	710	681	701								
56	PG1	42.1	49.6	64.4	76.7	90.3	97.0	134	165	184	209	267	289	278	300	362	388	477	506	720	749	861	895
	PG2	50.7	59.5	79.4	94.1	112	120	170	208	225	256	343	371	350	377								
	PG3	67.9	77.6	111	129	165	209	271	315	349	394	577	626	574	617								
	PG4	75.6	86.9	125	145	185	229	302	353	386	437	645	698	636	684								
63	PG1	39.6	47.7	60.0	72.4	85.3	94.7	127	161	174	204	252	275	262	286	338	371	456	482	697	724	834	867
	PG2	47.6	57.1	73.8	88.5	105	116	160	202	212	249	323	353	329	357								
	PG3	62.9	74.9	102	121	153	204	251	309	325	384	533	582	530	576								
	PG4	70.2	83.8	114	136	172	224	280	345	359	425	596	653	589	640								
71	PG1	39.2	45.2	58.2	68.9	83.4	90.1	124	150	169	197	245	260	252	270	333	346	431	461	669	696	800	832
	PG2	47.0	54.0	71.3	84.1	103	111	155	187	205	239	313	332	315	337								
	PG3	62.2	70.2	97.9	113	150	191	242	279	310	364	513	540	507	534								
	PG4	69.4	78.3	110	127	167	209	270	312	343	403	573	604	564	592								
80	PG1	37.2	42.6	56.8	64.3	78.9	85.1	117	141	164	186	236	252	242	259	315	341	411	435	655	681	783	814
	PG2	44.5	50.6	69.6	78.2	96.8	104	146	176	199	226	300	321	302	323								
	PG3	57.8	65.2	94.2	104	139	177	223	259	299	338	484	519	479	511								
	PG4	64.6	72.8	106	117	156	194	250	290	330	375	542	580	532	567								
90	PG1	36.7	42.2	53.7	62.2	74.9	83.0	113	138	153	180	222	243	228	248	299	322	399	415	627	652	750	780
	PG2	43.9	50.2	65.7	75.4	91.8	101	141	171	186	218	282	308	284	309								
	PG3	56.2	64.6	87.1	100	129	173	214	250	274	323	448	490	443	483								
	PG4	63.0	72.1	98.3	113	145	189	240	280	304	357	501	549	493	537								
100	PG1		40.0	48.1	60.9	67.1	78.8	99.5	130	133	175	179	228	201	234	282	306	388	403	509	632	611	756
	PG2		47.5		73.8		95.9		161		212		289		290								
	PG3		60.0		96.7		161		231		311		453		447								
	PG4		67.2		109		176		259		344		507		497								
112	PG1		39.5	46.3	57.6	64.2	74.9	98.7	126	130	164	171	184	192	206	270	289	379	392	498	518	596	620
	PG2		47.0		69.8		91.2		156		198												
	PG3		58.5		89.6		149		222		286												
	PG4		65.5		101		164		249		317												
125	PG1			44.9	51.6	62.1	67.3	94.6	110	126	142	165	177	185	197	261	276	367	383	488	508	584	607
140	PG1			42.6	49.5	60.1	64.4	91.5	109	122	138	159	170	178	190	251	267	347	371	475	494	568	591
160	PG1			41.0	48.0	56.8	62.4	87.0	105	115	134	153	164	171	183	241	257	333	351	455	473	544	566
180	PG1			39.4	45.6	54.4	60.4	83.9	101	111	130	150	157	167	175	230	247	328	336	439	457	525	546
220	PG1			37.9	43.9	52.6	57.0	79.2	96.4	108	123	146	154	161	172	222	236	309	331	432	449	516	537
224	PG1			35.7	42.0	50.5	54.6	75.9	92.8	103	118	136	150	150	166	213	227	295	312	428	445	512	532
250	PG1			34.1	40.7	48.2	53.0	72.1	87.6	98.0	115	129	139	143	155	202	218	279	297	409	425	489	509
280	PG1			33.1	38.2	46.8	50.8	69.4	84.3	94.9	109	125	132	139	147	194	207	268	281	388	404	467	486
315	PG1			32.4	38.6	44.6	48.5	67.7	79.9	91.0	105	119	128	133	143	190	199	257	270	374	389	447	465
355	PG1			30.9	35.5	43.8	47.1	64.4	76.9	86.8	101	117	123	130	137	181	195	245	260	363	378	435	452
400	PG1			34.8		44.9		75.1		97.1		120		134		185		248		359		429	
450	PG1			33.1		44.1		71.4		92.6													

B系列额定热容量(kW):

B series rated thermal capacities(kW):

iN		4	5	6	7	8	9	10	11	12	13	14	15	16	17	18	19	20	21	22	23	24	25	26	
5	PG1	66.3	86.9		122		150		233		286		330												
	PG2	101	140		223		272		458		662		797												
	PG3	135	202		313		391		664		1318		1786												
	PG4	166	250		403		500		862		1632		2158												
5.6	PG1	64.1	85.2		117		144		233		295		349		328										
	PG2	96.9	137		209		256		446		653		789		862										
	PG3	130	196		288		360		631		1264		1729		2015										
	PG4	160	242		371		461		821		1573		2084		2427										
6.3	PG1	62.4	81.9	96.5	110	134	137	155	218	277	282	337	351	374	353										
	PG2	93.8	130	152	194	235	240	272	406	516	597	726	752	815	836										
	PG3	124	182	259	261	381	327	451	555	957	1110	1384	1596	1748	1872										
	PG4	153	225	307	337	471	421	554	723	1166	1377	1712	1922	2105	2262										
7.1	PG1	58.8	77.7	94.7	104	127	130	148	217	275	284	341	346	372	364	388									
	PG2	87.6	122	148	182	221	225	256	397	501	589	712	715	775	804	867									
	PG3	114	168	252	240	350	300	414	535	913	1076	1326	1479	1613	1752	1882									
	PG4	140	208	298	310	433	387	510	697	1106	1339	1649	1781	1941	2109	2269									
8	PG1	55.4	73.3	90.6	98.9	120	124	141	201	254	268	322	330	365	356	393									
	PG2	82.1	114	140	171	205	212	240	362	454	539	648	659	736	750	832									
	PG3	105	154	233	222	317	278	376	473	801	959	1162	1330	1501	1590	1758									
	PG4	130	192	277	287	393	359	464	619	974	1190	1441	1598	1802	1909	2115									
9	PG1	52.7	69.6	85.8	94.6	113	119	134	193	252	260	322	321	347	351	381									
	PG2	77.5	108	132	162	192	202	225	345	444	515	638	633	678	723	773									
	PG3	96.9	142	214	208	292	262	346	446	776	897	1130	1258	1342	1512	1593									
	PG4	120	176	255	270	362	339	428	583	941	1118	1403	1513	1614	1815	1915									
10	PG1	44.3	64.6	80.6	88.6	107	112	127	183	232	249	301	307	337	342	374									
	PG2	64.2	98.9	123	150	180	189	212	323	403	485	583	591	650	684	745									
	PG3	77.4	127	197	189	269	240	319	409	687	830	999	1148	1271	1403	1516									
	PG4	95.9	158	235	246	335	310	395	537	835	1033	1244	1383	1528	1684	1818									
11.2	PG1	42.8	57.9	76.6	79.3	102	101	122	164	223	224	290	280	322	315	363									
	PG2	61.9	88.0	116	133	171	167	202	285	384	431	555	532	608	618	705									
	PG3	73.9	111	180	165	252	208	301	354	647	720	934	1010	1159	1243	1411									
	PG4	91.7	138	215	215	314	270	374	465	788	900	1167	1221	1400	1494	1688									
12.5	PG1	45.0	61.1	70.9	97.2	95.7	129	115	183	210	238	277	334	293	377	334									
	PG2	58.5	83.0	106	133	159	182	189	288	359	379	522	533	546	684	636									
	PG3	72.5	117	160	206	230	305	275	431	593	674	865	1054	1019	1264	1251									
	PG4	85.2	137	192	239	287	353	342	526	724	795	1078	1222	1235	1518	1500									
14	PG1	43.7	59.2	63.4	93.9	85.8	125	103	180	187	240	248	322	349	363	411									
	PG2	56.8	80.3	94.4	128	141	176	168	282	316	382	462	512	552	657	734									
	PG3	70.3	113	140	199	201	296	239	422	512	679	749	1006	1066	1214	1331									
	PG4	82.6	132	167	230	250	341	297	514	627	801	937	1166	1241	1455	1598									
16	PG1	41.5	57.2	66.4	89.5	105	122	137	171	203	221	259	318	334	365	379									
	PG2	54.0	77.3	88.6	122	140	172	190	268	311	349	404	503	528	652	672									
	PG3	66.8	109	121	189	211	287	324	401	526	617	699	984	1018	1194	1219									
	PG4	78.3	127	141	219	243	331	371	487	621	727	824	1142	1181	1433	1460									
18	PG1	40.3	55.4	64.3	86.4	101	118	126	168	203	222	261	306	332	351	399									
	PG2	52.4	74.9	85.8	118	136	166	175	262	311	352	407	482	521	626	698									
	PG3	64.7	105	116	182	205	277	298	393	527	621	703	945	1003	1142	1257									
	PG4	76.0	123	136	211	236	320	341	477	622	732	829	1091	1161	1371	1506									
20	PG1	38.0	53.1	61.9	82.8	96	113	129	160	189	209	239	296	317	340	366	411		475		795				
	PG2	49.4	71.8	82.6	113	129	159	180	250	289	329	371	464	497	602	639	745		838		993				
	PG3	61.2	101	112	174	193	265	305	374	487	581	639	907	953	1099	1146									
	PG4	71.6	118	131	201	223	307	350	454	575	684	753	1047	1104	1316	1375									
22.4	PG1	37.1	52.2	60.0	80.0	93.2	110	119	153	189	201	242	289	306	337	354	409	431	473	492	814	847	974		
	PG2	48.1	70.6	80.1	109	125	155	165	237	289	313	374	450	478	586	614	725	762	818	849	993	1033	1188		
	PG3	59.5	99.8	109	168	187	257	279	347	486	542	645	859	912	1051	1099									
	PG4	69.8	117	127	193	216	297	320	423	574	639	759	994	1057	1261	1318									
25	PG1	35.2	49.4	57.5	77.3	89.3	105	114	145	181	190	226	273	300	322	350	399	427	461	487	783	814	936	983	
	PG2	45.5	66.6	76.6	105	119	147	158	222	275	294	349	419	462	548	598	692	741	778	828	955	993	1142	1199	
	PG3	56.1	93.8	104	160	179	239	268	318	462	498	602	777	867	956	1053									
	PG4	65.7	109	121	185	207	276	306	388	547	588	708	899	1004	1147	1264									
28	PG1	33.8	47.7	56.5	73.4	86.3	100	111	138	173	181	217	266	283	318	334	388	415	446	473	762	793	912	958	
	PG2	43.5	64.0	75.3	98.8	115	139	154	211	262	278	332	406	430	535	559	659	706	740	786	952	991	1140	1197	
	PG3	52.9	88.7	103	148	173	222	259	286	431	462	560	745	785	925	958									
	PG4	62.1	103	120	171	199	257	297	362	509	547	660	863	909	1109	1148									

B系列额定热容量(kW):

B series rated thermal capacities(kW):

iN		4	5	6	7	8	9	10	11	12	13	14	15	16	17	18	19	20	21	22	23	24	25	26
31.5	PG1	32.0	45.2	53.4	69.7	83.1	95.6	106	131	163	172	205	250	276	301	328	370	403	423	458	742	772	888	932
	PG2	41.2	60.5	71.0	93.6	111	132	146	199	245	263	311	378	418	499	545	618	673	688	748	927	965	1110	1165
	PG3	49.6	82.7	96.7	138	165	208	240	275	394	428	513	675	752	846	927								
	PG4	58.2	96.5	113	160	189	240	276	337	467	508	606	784	873	1014	1111								
35.5	PG1	30.1	42.6	51.5	66.2	78.9	90.8	101	126	155	166	195	241	259	291	311	361	383	409	433	726	755	868	911
	PG2	38.5	56.6	68.2	88.4	105	125	138	190	232	252	295	363	388	480	509	596	630	660	695	885	921	1059	1111
	PG3	45.6	75.7	91.4	128	153	190	224	261	367	407	478	642	684	805	847								
	PG4	53.6	88.7	107	148	176	221	257	318	434	483	565	746	794	966	1017								
40	PG1	26.3	37.0	48.9	57.9	75.3	84.9	96.4	119	147	156	186	228	250	278	301	343	373	388	419	703	731	841	883
	PG2	33.5	48.8	64.5	76.7	99.4	116	132	178	218	237	279	341	373	453	489	560	607	618	667	844	877	1009	1060
	PG3	38.4	63.0	85.3	106	143	172	210	239	340	375	445	592	649	749	805								
	PG4	45.2	73.9	99.8	126	164	200	241	293	403	446	526	690	755	900	968								
45	PG1	25.7	36.0	45.9	56.2	71.4	78.0	91.5	109	141	144	178	211	236	258	287	321	355	359	396	665	692	796	836
	PG2	32.7	47.5	60.3	74.0	93.8	106	124	163	209	216	267	313	351	418	463	519	570	569	624	778	810	931	978
	PG3	37.3	60.7	78.3	102	132	155	192	215	321	336	421	533	599	679	753								
	PG4	44.0	71.3	91.6	118	152	180	221	265	382	398	499	621	698	816	903								
50	PG1	25.9	35.8	40.0	55.4	62.5	76.6	85.6	109	133	146	169	216	218	268	266	317	331	386	367	611	635	730	767
	PG2	32.9	46.9	52.2	72.6	81.4	103	116	160	195	216	250	315	322	424	427	498	529	596	574	670	724	832	874
	PG3	37.3	59.1	65.3	98.6	110	148	174	210	295	333	389	535	539	686	684								
	PG4	43.8	69.5	76.6	114	127	173	201	256	350	397	462	620	629	820	821								
56	PG1	23.9	33.0	39.0	51.4	60.6	70.7	78.9	99.1	122	134	155	198	223	247	276	305	326	365	393	599	623	717	753
	PG2	30.2	43.3	50.8	67.4	78.8	95.3	106	145	179	197	228	287	323	388	432	478	506	560	601	683	710	817	858
	PG3	33.6	53.3	63.0	89.4	105	133	157	186	264	298	346	479	541	617	688								
	PG4	39.7	62.9	74.0	104	122	155	181	228	315	354	413	555	628	738	823								
63	PG1	23.0	31.7	38.7	49.7	59.8	68.2	77.4	95.5	121	129	157	189	204	237	254	295	314	353	371	567	590	679	713
	PG2	29.1	41.6	50.2	65.1	77.4	91.9	103	139	175	189	229	273	294	370	395	460	486	540	563	635	661	760	798
	PG3	31.8	50.3	61.4	84.8	102	125	150	175	256	280	345	449	482	581	620								
	PG4	37.6	59.5	72.2	99.0	119	147	173	215	304	334	409	521	561	698	740								
71	PG1	21.3	30.2	35.7	47.3	55.5	63.9	71.7	88.4	111	121	144	180	195	224	244	279	304	333	360	547	569	654	687
	PG2	27.0	39.5	46.2	62	71.8	86.0	95.6	129	159	177	208	258	281	347	377	431	468	505	544	602	626	719	756
	PG3	28.9	46.6	55.5	78.4	92.8	113	135	157	227	253	309	413	454	537	585								
	PG4	34.3	55.3	65.4	92.1	108	134	156	194	271	303	366	482	528	644	701								
80	PG1		32.5	34.2	48.2	53.6	68.2	69.2	103	106	138	138	185	186	208	231	285	287	399	339	560	538	670	650
	PG2			44.5		69.4		92.3		153		200		266		353		438		509		592		715
	PG3			52.3		88.0		127		212		290		417		538								
	PG4			61.8		103		148		255		346		487		647								
90	PG1		31.8	32.6	46.7	51.0	66.7	64.9	99.9	98.7	135	129	177	190	199	214	273	292	386	404	554	576	662	695
	PG2			42.3		66.0		86.5		142		187												
	PG3			48.5		81.5		115		190		262												
	PG4			57.6		95.4		135		230		314												
100	PG1		30.3	34.8	44.2	51.5	63.2	68.7	96.0	115	128	148	167	182	187	205	258	280	363	391	549	571	657	690
112	PG1		29.2	34.0	42.5	50.0	60.8	67.1	91.4	111	122	144	159	172	179	193	246	264	352	367	497	517	595	625
125	PG1		27.9	32.5	40.6	47.3	58.0	63.7	87.5	106	117	136	151	164	170	184	234	252	331	356	497	517	595	625
140	PG1		26.6	31.3	38.6	45.6	54.7	61.3	82.8	101	111	130	146	156	164	175	225	240	320	335	467	486	559	587
160	PG1		24.5	29.9	35.2	43.5	50.0	58.4	75.5	96.8	105	125	138	150	155	169	213	231	302	323	453	471	542	569
180	PG1		24.0	28.6	34.3	41.4	48.8	55.4	73.5	91.6	99.2	118	130	142	146	159	199	218	282	306	433	450	518	544
200	PG1		23.2	26.3	34.0	37.8	47.8	50.7	71.9	83.7	96.9	112	128	134	144	151	198	204	273	286	401	417	480	504
224	PG1		21.6	25.8	31.7	36.9	44.7	49.4	67.6	81.6	90.8	106	120	132	134	148	186	204	255	277	400	416	478	502
250	PG1		21.1	24.8	30.6	36.5	43.1	48.4	65.4	79.7	87.9	103	116	123	130	139	180	191	247	259	371	386	444	466
280	PG1		20.1	23.2	28.7	34.1	41.1	45.3	62.5	74.8	83.0	96.9	108	119	122	134	169	184	236	250	354	368	423	444
315	PG1		18.8	22.6	26.9	32.8	38.6	43.7	58.4	72.4	79.2	93.7	102	112	115	126	160	174	220	239	333	346	398	418
355	PG1			21.6		30.8		41.7		69.1		88.5		105		119		164		223		317		383
400	PG1			20.2		28.9		39.3		64.5		84.3												

H1SH3 ~ H1SH19

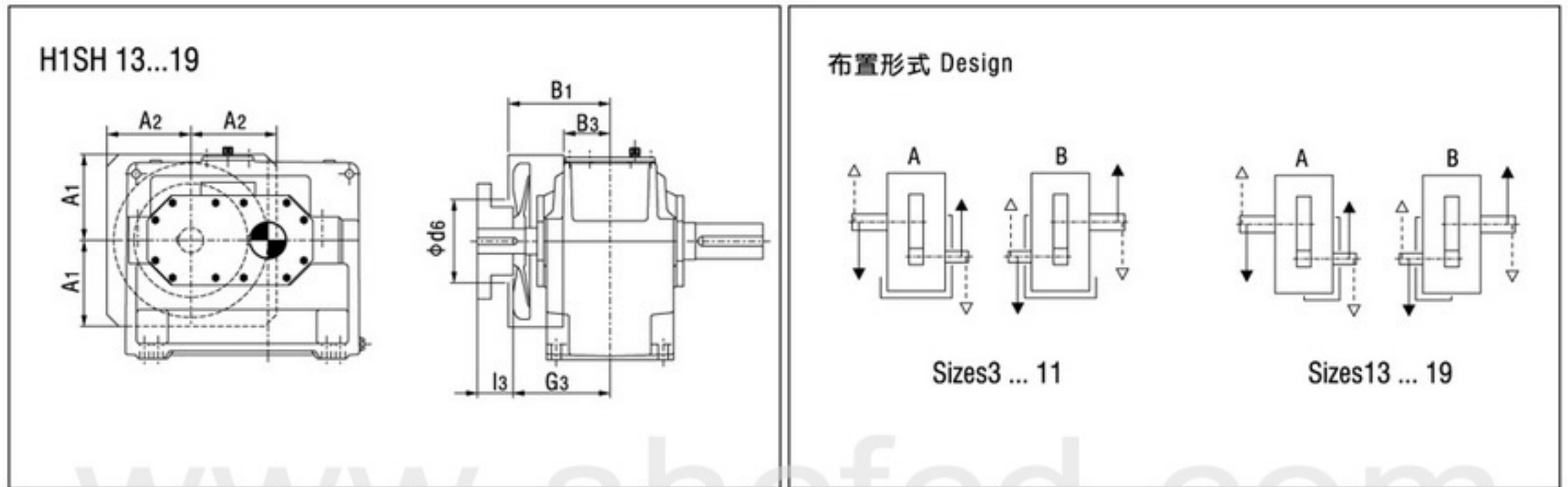
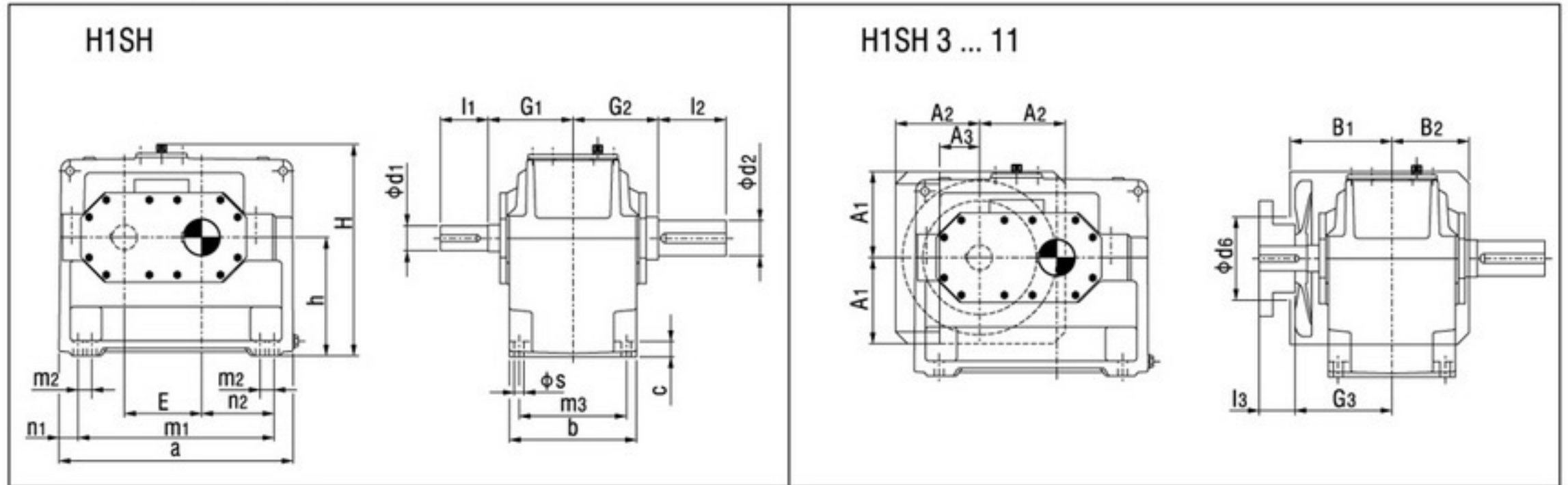

机座号 Size	$i_N = 1.25-2.8$			$i_N = 1.6-2.8$			$i_N = 2-2.8$			$i_N = 3.15-4$			$i_N = 4.5-5.6$			a	A1	A2	A3	b	B1	B2
	d1	l1	l3	d1	l1	l3	d1	l1	l3	d1	l1	l3	d1	l1	l3							
3	60	125	105							45	100	80	32	80	60	420	150	145	80	200	205	130
5	85	160	130							60	135	105	50	110	80	580	225	215	115	285	255	185
7	100	200	165							75	140	105	60	140	105	690	225	250	120	375	300	230
9	110	200	165							90	165	130	75	140	105	805	300	265	140	425	330	265
11				130	240	205				110	205	170	90	170	135	690	360	330	190	515	375	320
13				150	245	200				130	245	200	100	210	165	1100	415	350	-	580	430	-
15							180	290	240	150	250	200	125	250	200	1295	500	430	-	545	430	-
17							200	330	280	170	290	240	140	250	200	1410	550	430	-	615	470	-
19							220	340	290	190	340	290	160	300	250	1590	630	475	-	690	510	-

机座号 Size	B3	c	d2	d6	E	G1	G2	G3	h	H	l2	m1	m2	m3	n1	n2	s	润滑油oil (l)		重量 weight (kg)
																		(1)*	(2)*	
3	-	28	60	130	130	170	170	190	200	375	125	310	-	160	55	110	19	7	5.5	128
5	-	35	85	190	185	210	210	240	290	525	160	440	-	240	70	160	24	22	19	302
7	-	45	105	245	225	250	250	285	350	625	200	540	-	315	75	195	28	42	36	547
9	-	50	125	280	265	280	270	315	420	735	210	625	-	350	90	225	35	68	60	862
11	-	60	150	350	320	325	320	360	500	875	240	770	-	440	95	280	35	120	106	1515
13	150	70	180	350	370	365	360	410	580	1020	310	870	-	490	115	315	42	175	155	2395
15	120	80	220	450	442	360	360	410	600	1115	350	1025	-	450	135	370	48	190	156	3200
17	150	80	240	445	490	400	400	450	670	1235	400	1170	130	530	120	425	42	270	225	4250
19	190	90	270	445	555	440	440	490	760	1395	450	1290	150	590	150	465	48	390	330	5800

(1)*轴封; (2)*迷宫式密封。

(1)*Shaft seal, (2)*Labyrinth seal.

H2.H4 ~ H2.H12

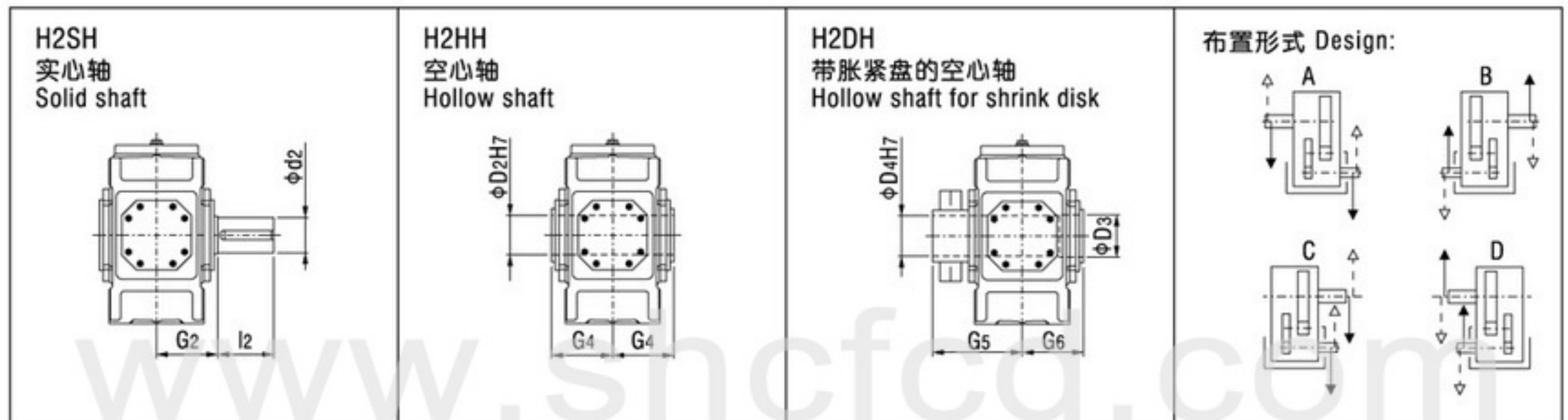
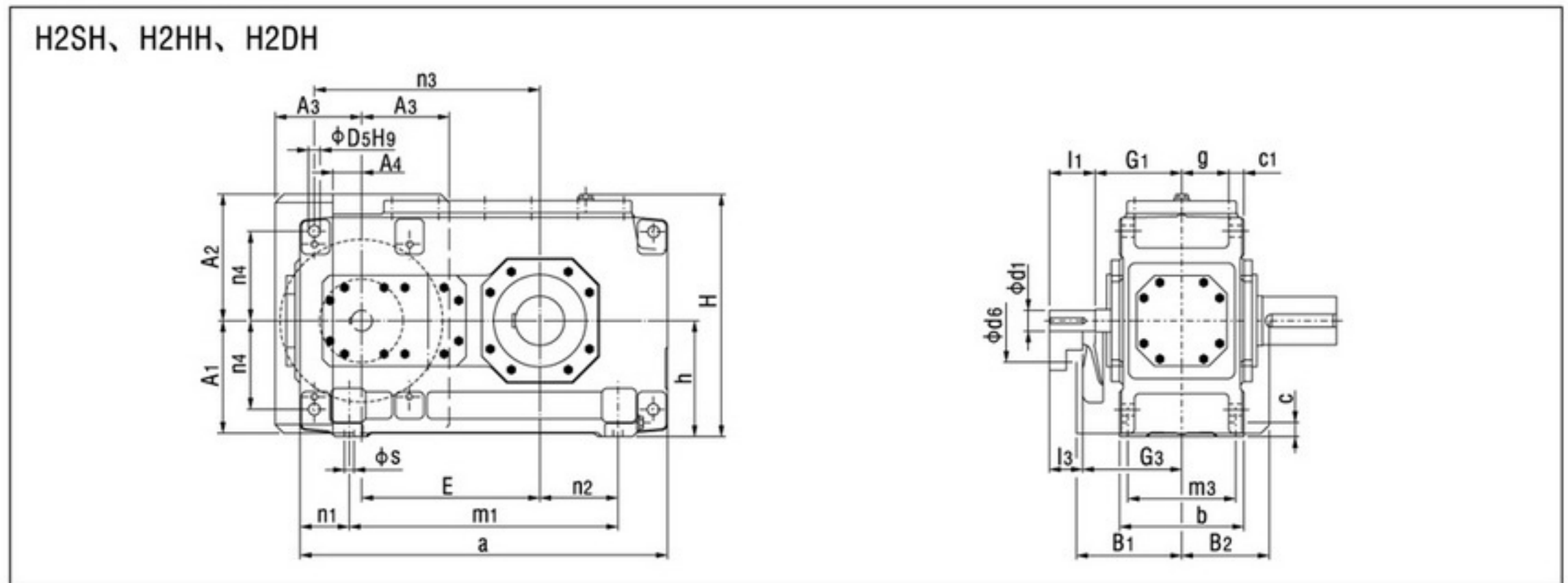

机座号 Size	$i_N = 6.3 - 11.2$			$i_N = 8 - 14$			$i_N = 12.5 - 22.4$			$i_N = 16 - 28$			a	A1	A2	A3	A4	b	B1	B2	c	c1	d2	d6	D2	D3
	d1	l1	l3	d1	l1	l3	d1	l1	l3	d1	l1	l3														
4	45	100	80				32	80	60				565	195	225	150	30	215	205	158	28	30 ± 1	80	136	80	85
5	50	100	80				38	80	60				640	225	260	175	55	255	230	177.5	28	30 ± 1	100	150	95	100
6				50	100	80				38	80	60	720	225	260	175	55	255	230	177.5	28	30 ± 1	110	150	105	110
7	60	135	105				50	110	80				785	272	305	210	70	300	255	210	35	36 ± 1	120	200	115	120
8				60	135	105				50	110	80	890	272	305	210	70	300	255	210	35	36 ± 1	130	200	125	130
9	75	140	110				60	140	110				925	312	355	240	100	370	285	245	40	45 ± 1.5	140	200	135	140
10				75	140	110				60	140	110	1025	312	355	240	100	370	285	245	40	45 ± 1.5	160	200	150	150
11	90	165	130				70	140	105				1105	372	420	285	135	430	325	285	50	54 ± 1.5	170	210	165	165
12				90	165	130				70	140	105	1260	372	420	285	135	430	325	285	50	54 ± 1.5	180	210	180	180

机座号 Size	D4	D5	E	g	G1	G2	G3	G4	G5	G6	h	H	l2	m1	m3	n1	n2	n3	n4	s	润滑油oil (l)		重量 weight (kg)
																					(1)*	(2)*	
4	85	24	270	77.5	170	140	190	140	205	140	200	415	170	355	180	105	85	345	150	19	10	7	190
5	100	24	315	97.5	195	165	215	165	240	165	230	482	210	430	220	105	100	405	180	19	15	11	300
6	110	24	350	97.5	195	165	215	165	240	165	230	482	210	510	220	105	145	440	180	19	16	12	355
7	120	28	385	114	210	195	240	195	280	195	280	572	210	545	260	120	130	500	215	24	27	21	505
8	130	28	430	114	210	195	240	195	285	195	280	582	250	650	260	120	190	545	215	24	30	23	590
9	140	36	450	140	240	235	270	235	330	235	320	662	250	635	320	145	155	585	245	28	42	33	830
10	150	36	500	140	240	235	270	235	350	235	320	662	300	735	320	145	205	635	245	28	45	34	960
11	165	40	545	161	275	270	310	270	400	270	380	782	300	775	370	165	180	710	300	35	71	58	1335
12	180	40	615	161	275	270	310	270	405	270	380	790	300	930	370	165	265	780	300	35	76	60	1615

(1)*轴封; (2)*迷宫式密封。

(1)*Shaft seal, (2)*Labyrinth seal.

H2.H13 ~ H2.H26

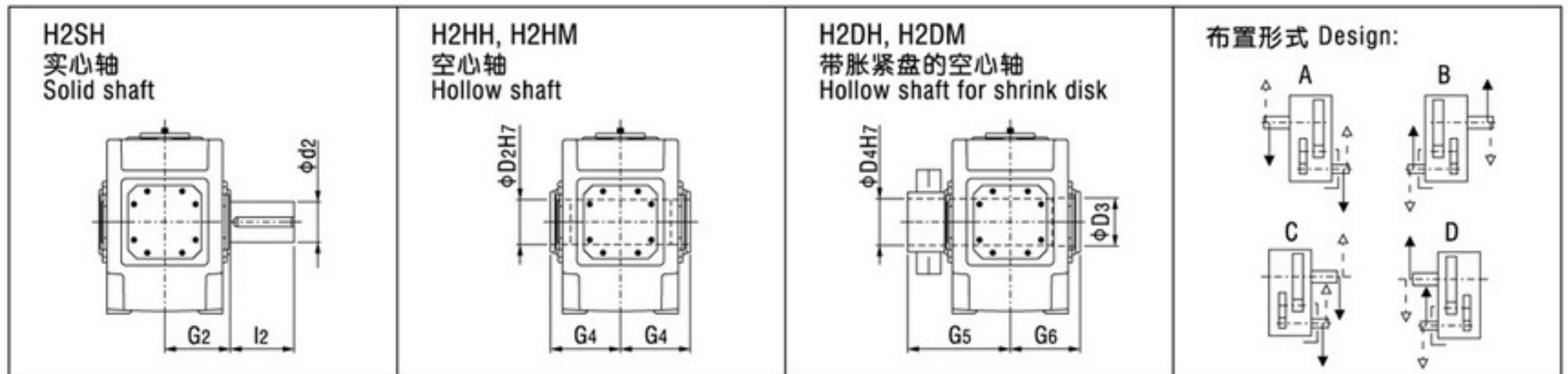
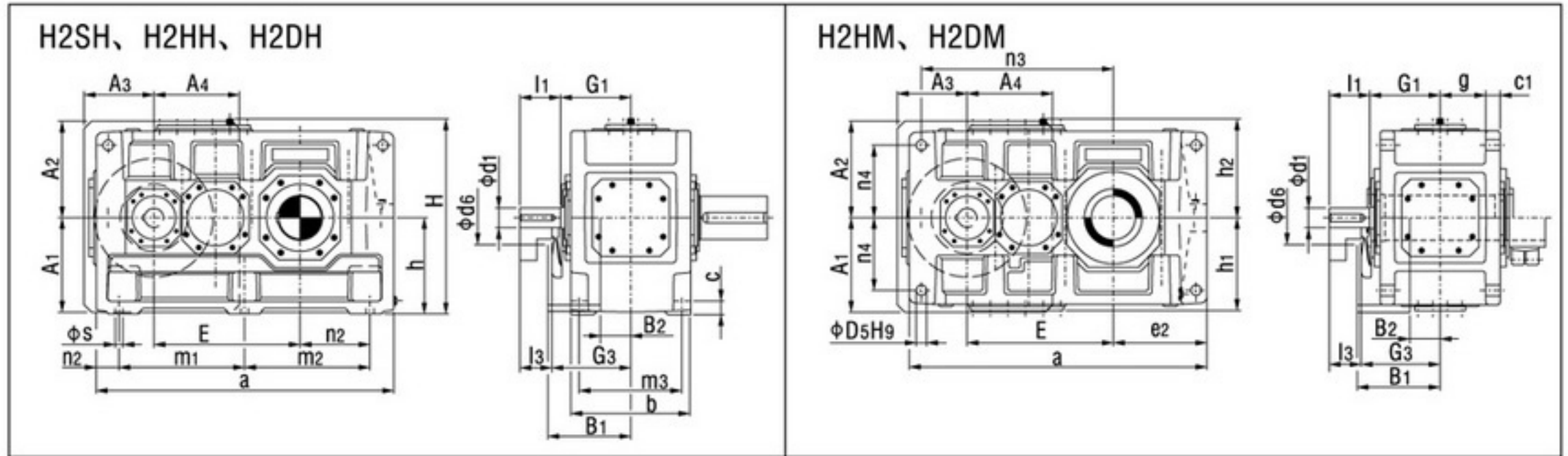

机座号 Size	$i_N=6.3-11.2$			$i_N=7.1-12.5$			$i_N=8-14$			$i_N=12.5-20$			$i_N=14-22.4$			$i_N=16-25$			a	A1	A2	A3	A4	b	B1	B2	c	c1	d2	d6	D2	D3
	d1	l1	l3	d1	l1	l3	d1	l1	l3	d1	l1	l3	d1	l1	l3	d1	l1	l3														
13	100	205	170						85	170	135								1290	430	460	330	365	550	385	135	60	61±2	200	250	190	190
14							100	205	170							85	170	135	1430	430	460	330	365	550	385	135	60	61±2	210	250	210	210
15	120	210	165							100	210	165							1550	490	500	370	440	625	430	155	70	72±2	230	280	230	230
16				120	210	165						100	210	165					1640	490	500	370	440	625	430	155	70	72±2	240	280	240	240
17	125	245	200							110	210	165							1740	540	565	435	505	690	485	140	80	81±2	250	280	250	250
18				125	245	200						110	210	165					1860	540	565	435	505	690	485	140	80	81±2	270	280	275	280
19	150	245	200							120	210	165							2010	600	600	500	450	790	540	190	90	91±2	290	310	-	285
20				150	245	200						120	210	165					2130	600	600	500	450	790	540	190	90	91±2	300	310	-	310
21	170	290	240							140	250	200							2140	680	680	500	610	830	565	200	100	100±2	320	450	-	330
22				170	290	240						140	250	200					2250	680	680	500	610	830	565	200	100	100±2	340	450	-	340
23	190	330	280							150	250	200							2380	770	770	550	550	930	630	220	115	120±2	360	450	-	360
24				190	330	280						150	250	200					2510	770	770	550	550	930	630	220	115	120±2	380	450	-	380
25	200	340	290							170	300	250							2580	845	860	550	550	1045	670	240	130	120±2	400	450	-	400
26				200	340	290						170	300	250					2760	845	860	550	550	1045	670	240	130	120±2	420	450	-	430

机座号 Size	D4	D5	e2	E	g	G1	G2	G3	G4	G5	G6	h	h1	h2	H	l2	m1	m2	m3	n1	n2	n3	n4	s	润滑油oil (l)			重量 weight (kg)	
																									H2.H		H2.M	H2.H	H2.M
																									(1)*	(2)*			
13	190	48	405	635	211.5	330	335	365	335	480	335	440	450	460	900	350	545	545	475	100	305	835	340	35	135	120	110	2000	1880
14	210	48	475	705	211.5	330	335	365	335	480	335	440	450	460	900	350	545	685	475	100	375	905	340	35	140	130	115	2570	2430
15	230	55	485	762	238	365	380	410	380	550	380	500	490	500	1000	410	655	655	535	120	365	1005	375	42	210	190	160	3430	3240
16	240	55	530	808	238	365	380	410	380	550	380	500	490	500	1000	410	655	745	535	120	410	1050	375	42	215	200	165	3655	3465
17	250	55	525	860	259	420	415	465	415	600	415	550	555	560	1110	410	735	735	600	135	390	1145	425	42	290	260	230	4650	4420
18	280	55	585	920	259	420	415	465	415	600	415	550	555	560	1110	470	735	855	600	135	450	1205	425	42	300	270	240	5125	4870
19	285	65	590	997	299	475	465	520	-	670	465	620	615	620	1240	470	850	850	690	155	435	1345	475	48	320	-	300	6600	6300
20	310	65	650	1057	299	475	465	520	-	670	465	620	615	620	1240	500	850	970	690	155	495	1405	475	48	340	-	320	7500	7200
21	330	75	655	1067	310	495	490	545	-	715	490	700	685	690	1390	500	900	900	720	170	485	1400	520	56	320	-	350	8900	8400
22	340	75	710	1122	310	495	490	545	-	725	490	700	685	690	1390	550	900	1010	720	170	540	1455	520	56	340	-	370	9600	9200
23	360	80	730	1185	342	560	540	610	-	785	540	780	770	770	1550	590	1010	1010	810	180	550	1560	580	56	430	-	470	11600	11000
24	380	80	795	1250	342	560	540	610	-	805	540	780	770	770	1550	590	1010	1140	810	180	615	1625	580	56	450	-	500	13000	12300
25	400	90	790	1325	400	600	605	650	-	875	605	860	860	860	1720	650	1090	1090	910	200	590	1685	660	66	600	-	660	15500	14700
26	430	90	880	1415	400	600	605	650	-	900	605	860	860	860	1720	650	1090	1270	910	200	680	1775	660	66	640	-	700	17200	16200

(1)*轴封; (2)*迷宫式密封。

(1)*Shaft seal, (2)*Labyrinth seal.

H3.H5 ~ H3.H12

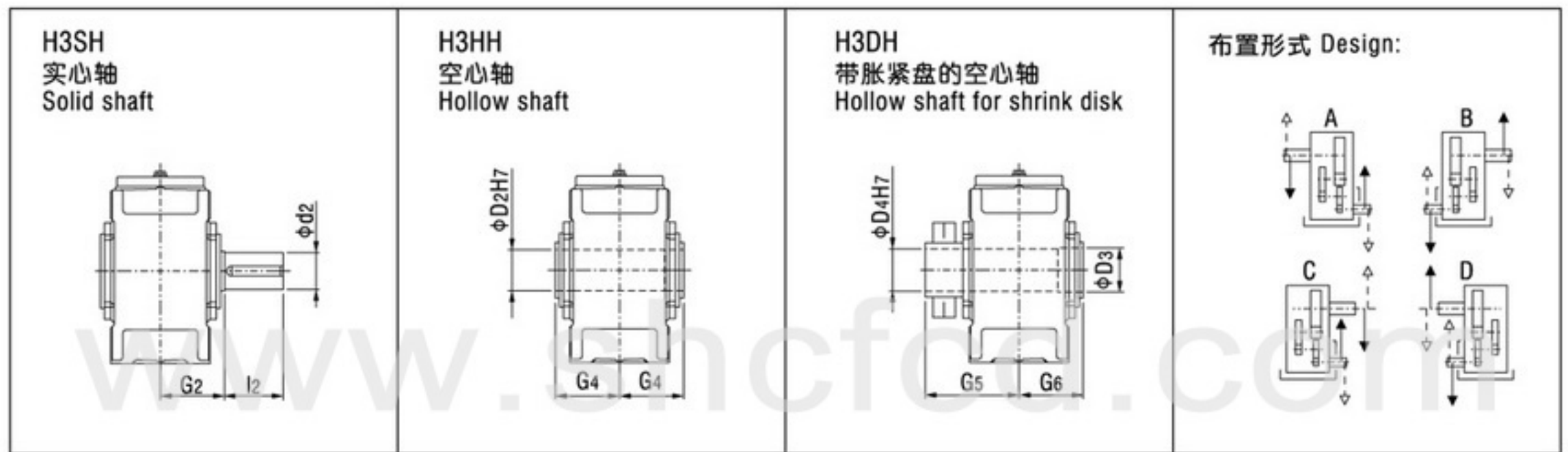
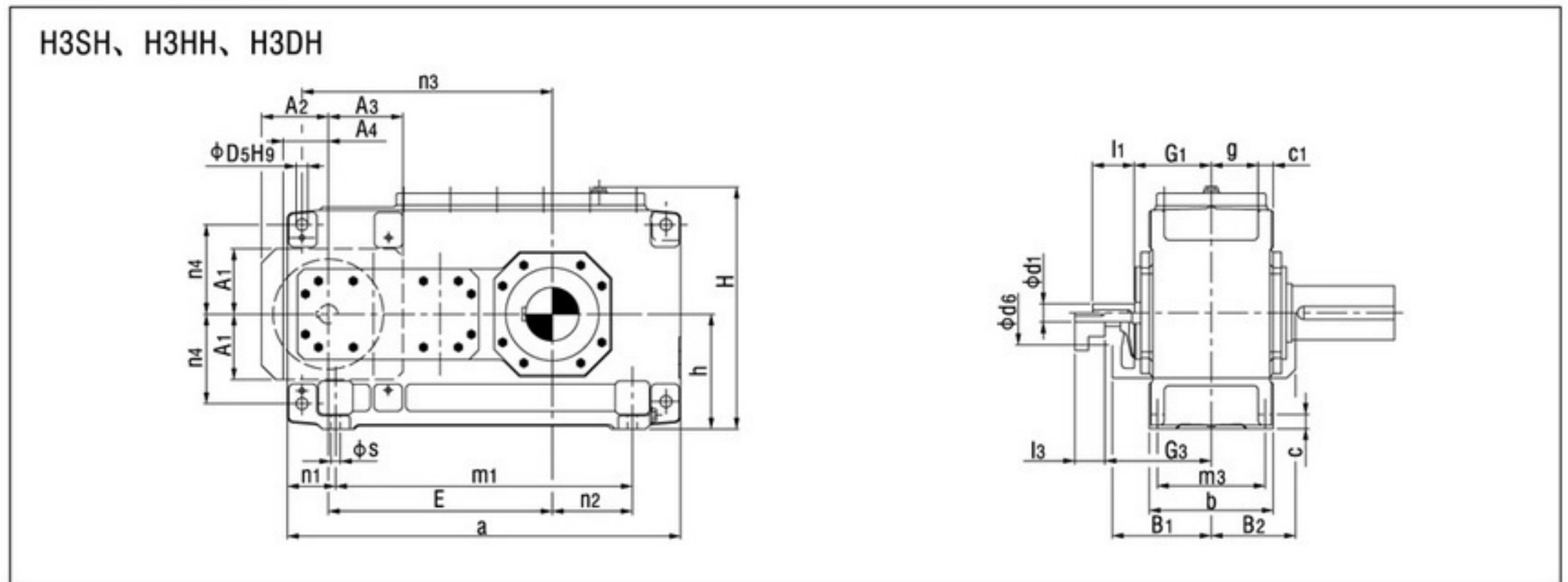

机座号 Size	$i_N = 25 - 45$			$i_N = 31.5 - 56$			$i_N = 50 - 63$			$i_N = 63 - 80$			$i_N = 71 - 90$			$i_N = 90 - 112$			a	A4	A1	A2	A3	b	B1	B2	c1	c	d2
	d1	l1	l3	d1	l1	l3	d1	l1	l3	d1	l1	l3	d1	l1	l3	d1	l1	l3											
5	40	70	70				30	50	50				24	40	40				690	80	137	135	140	255	215	175	30±1	28	100
6				40	70	70				30	50	50				24	40	40	770	80	137	135	140	255	215	175	30±1	28	110
7	45	80	80				35	60	60				28	50	50				845	100	157	160	180	300	245	205	36±1	35	120
8				45	80	80				35	60	60				28	50	50	950	100	157	160	180	300	245	205	36±1	35	130
9	60	125	105				45	100	80				32	80	60				1000	120	182	190	205	370	295	240	45±1.5	40	140
10				60	125	105				45	100	80				32	80	60	1100	120	182	190	205	370	295	240	45±1.5	40	160
11	70	120	120				50	80	80				42	70	70				1200	150	218	220	255	430	325	280	54±1.5	50	170
12				70	120	120				50	80	80				42	70	70	1355	150	218	220	255	430	325	280	54±1.5	50	180

机座号 Size	d6	D2	D3	D4	D5	E	g	G1	G2	G3	G4	G5	G6	h	H	l2	m1	m3	n1	n2	n3	n4	s	润滑油oil (l)	重量 weight (kg)
5	60	95	100	100	24	405	97.5	160	165	220	165	240	165	230	482	210	480	220	105	100	455	180	19	15	320
6	60	105	110	110	24	440	97.5	160	165	220	165	240	165	230	482	210	560	220	105	145	490	180	19	17	365
7	75	115	120	120	28	495	114	185	195	250	195	280	195	280	572	210	605	260	120	130	560	215	24	28	540
8	75	125	130	130	28	540	114	185	195	250	195	285	195	280	582	250	710	260	120	190	605	215	24	30	625
9	90	135	140	140	36	580	140	230	235	300	235	330	235	320	662	250	710	320	145	155	660	245	28	45	875
10	90	150	150	150	36	630	140	230	235	300	235	350	235	320	662	300	810	320	145	205	710	245	28	46	1020
11	100	165	165	165	40	705	161	255	270	330	270	400	270	380	782	300	870	370	165	180	805	300	35	85	1400
12	100	180	180	180	40	775	161	255	270	330	270	405	270	380	790	300	1025	370	165	265	875	300	35	90	1675

H3.H13 ~ H3.H26

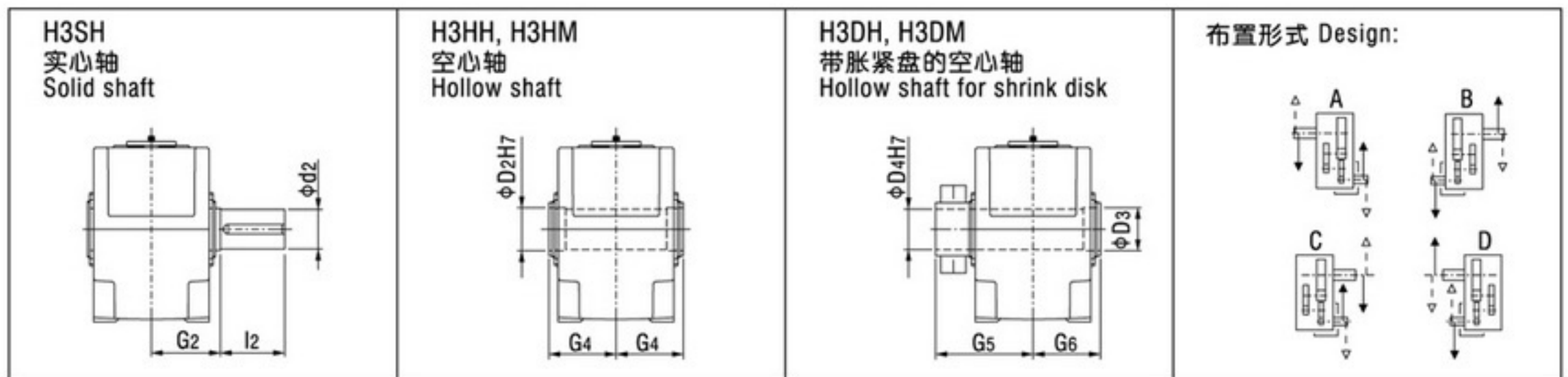
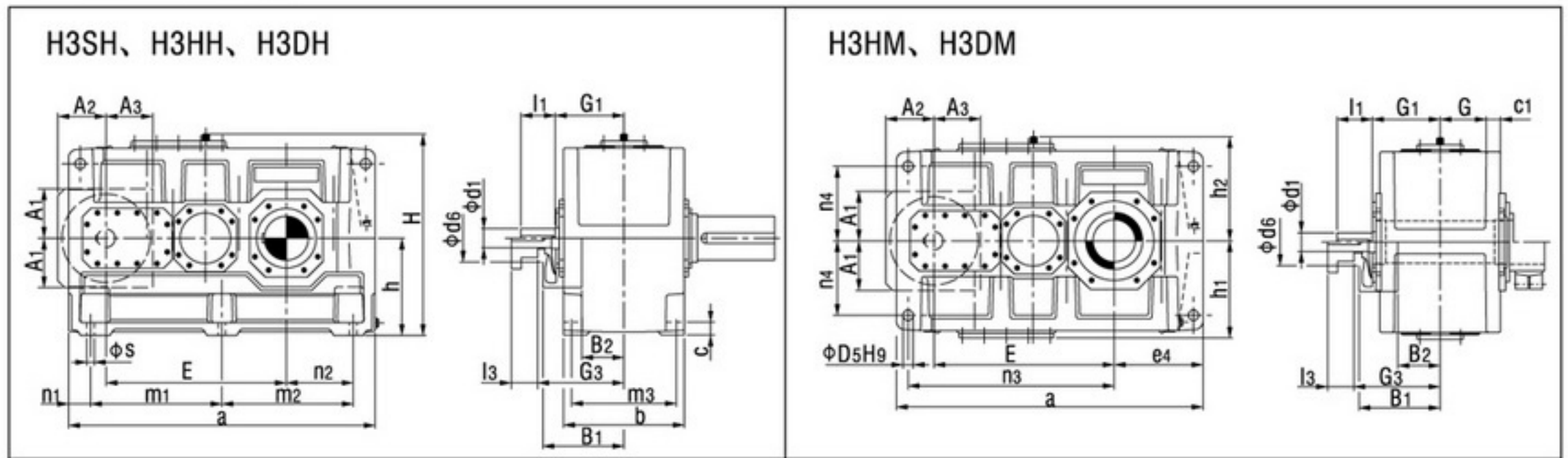

机座号 Size	i _N =22.4-45			i _N =25-50			i _N =50-63			i _N =56-71			i _N =71-90			i _N =80-100			a	A1	A2	A3	b	B1	B2	c	c1	d2	d6	D2	D3
	d1	l1	l3	d1	l1	l3	d1	l1	l3	d1	l1	l3	d1	l1	l3	d1	l1	l3													
13	85	160	130				60	135	105				50	110	80				1395	225	225	212	550	380	195	60	61±2	200	120	190	190
14				i _N =28-55						i _N =63-80						i _N =90-112			1535	225	225	212	550	380	195	60	61±2	210	120	210	210
15	100	200	165				75	140	105				60	140	105				1680	270	265	252	625	415	205	70	72±2	230	150	230	230
16				100	200	165				75	140	105				60	140	105	1770	270	265	252	625	415	205	70	72±2	240	150	240	240
17	100	200	165				75	140	105				60	140	105				1770	270	265	252	690	445	235	80	81±2	250	150	250	250
18				100	200	165				75	140	105				60	140	105	1890	270	265	252	690	445	235	80	81±2	270	150	275	280
19	110	200	*				90	165	*				75	140	*				2030	*	*	*	790	*	*	90	91±2	290	*	-	285
20				110	200	*				90	165	*				75	140	*	2150	*	*	*	790	*	*	90	91±2	300	*	-	310
21	130	240	*				110	205	*				90	170	*				2340	*	*	*	830	*	*	100	100±2	320	*	-	330
22				130	240	*				110	205	*				90	170	*	2450	*	*	*	830	*	*	100	100±2	340	*	-	340
23	130	240	-				110	205	-				90	170	-				2530	-	-	-	930	-	-	115	120±2	360	-	-	360
24				130	240	-				110	205	-				90	170	-	2660	-	-	-	930	-	-	115	120±2	380	-	-	380
25	150	245	-				130	245	-				100	210	-				2830	-	-	-	1045	-	-	130	120±2	400	-	-	400
26				150	245	-				130	245	-				100	210	-	3010	-	-	-	1045	-	-	130	120±2	420	-	-	430

机座号 Size	D4	D5	e2	E	g	G1	G2	G3	G4	G5	G6	h	h1	h2	H	l2	m1	m2	m3	n1	n2	n3	n4	s	润滑油 oil (l)		重量 weight(kg)	
																									H3.H	H3.M	H3.H	H3.M
13	190	48	405	820	211.5	310	335	385	335	480	335	440	450	460	900	350	597.5	597.5	475	100	305	940	340	35	160	125	2295	2155
14	210	48	475	890	211.5	310	335	385	335	480	335	440	450	460	900	350	597.5	737.5	475	100	375	1010	340	35	165	130	2625	2490
15	230	55	485	987	238	350	380	420	380	550	380	500	490	500	1000	410	720	720	535	120	365	1135	375	42	235	190	3475	3260
16	240	55	530	1033	238	350	380	420	380	550	380	500	490	500	1000	410	720	810	535	120	410	1180	375	42	245	195	3875	3625
17	250	55	525	1035	259	380	415	450	415	600	415	550	555	560	1110	410	750	750	600	135	390	1175	425	42	305	240	4560	4250
18	280	55	585	1095	259	380	415	450	415	600	415	550	555	560	1110	470	750	870	600	135	450	1235	425	42	315	250	5030	4740
19	285	65	590	1190	299	430	465	*	-	670	465	620	615	620	1240	470	860	860	690	155	435	1365	475	48	420	390	6700	6200
20	310	65	650	1250	299	430	465	*	-	670	465	620	615	620	1240	500	860	980	690	155	495	1425	475	48	450	415	8100	7600
21	330	75	655	1387	310	470	490	*	-	715	490	700	685	690	1390	500	1000	1000	720	170	485	1600	520	56	470	510	9100	8500
22	340	75	710	1442	310	470	490	*	-	725	490	700	685	690	1390	550	1000	1110	720	170	540	1655	520	56	490	540	9800	9300
23	360	80	730	1505	342	510	540	-	-	785	540	780	770	790	1570	590	1085	1085	810	180	550	1725	580	56	620	690	11500	10600
24	380	80	795	1570	342	510	540	-	-	805	540	780	770	790	1570	590	1085	1215	810	180	615	1790	580	56	650	725	13400	12500
25	400	90	790	1695	400	570	605	-	-	875	605	860	860	860	1720	650	1215	1215	910	200	590	1965	660	66	880	970	16100	15200
26	430	90	880	1785	400	570	605	-	-	900	605	860	860	860	1720	650	1215	1395	910	200	680	2055	660	66	935	1030	17600	16500

注：“*”按客户要求供货。

Note: * On request.

H4.H7 ~ H4.H12

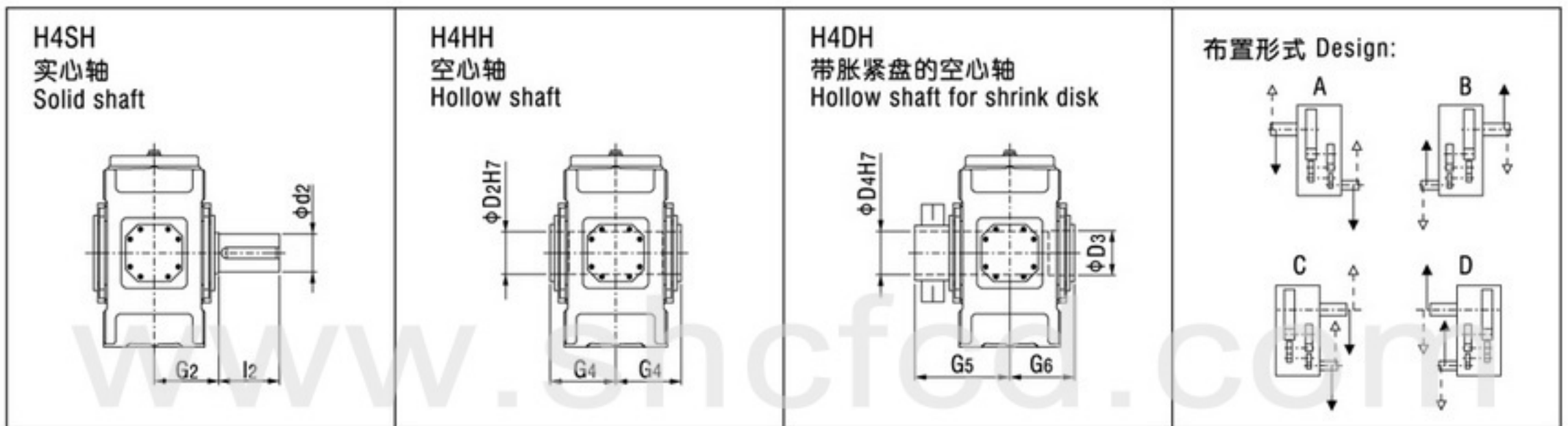
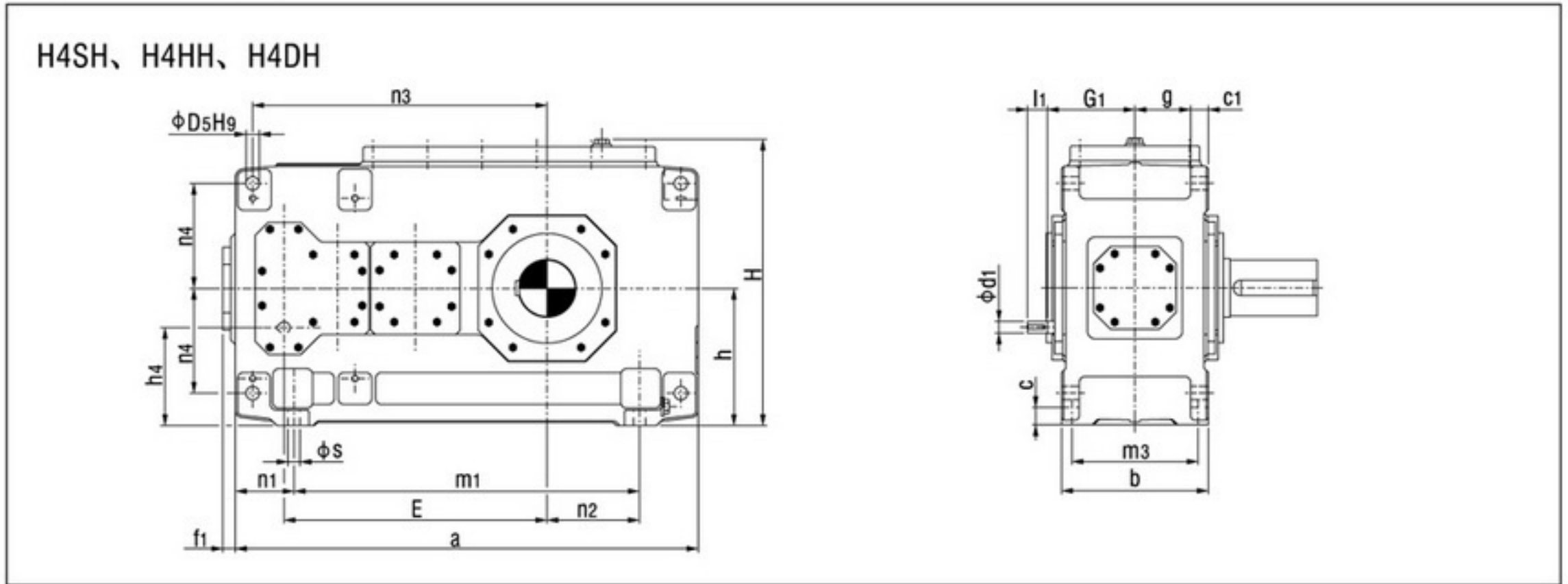

机座号 Size	$i_N = 100 - 180$		$i_N = 125 - 224$		$i_N = 200 - 355$		$i_N = 250 - 450$		a	b	c	c1	d2	D2	D3	D4	D5	E
	d1	l1	d1	l1	d1	l1	d1	l1										
7	30	50			24	40			845	300	35	36 ± 1	120	115	120	120	28	495
8			30	50			24	40	950	300	35	36 ± 1	130	125	130	130	28	540
9	35	60			28	50			1000	370	40	45 ± 1.5	140	135	140	140	36	580
10			35	60			28	50	1100	370	40	45 ± 1.5	160	150	150	150	36	630
11	45	100			32	80			1200	430	50	54 ± 1.5	170	165	165	165	40	705
12			45	100			32	80	1355	430	50	54 ± 1.5	180	180	180	180	40	775

机座号 Size	f1	g	G1	G2	G4	G5	G6	h	h4	H	l2	m1	m3	n1	n2	n3	n4	s	润滑油 oil (l)	重量 weight (kg)
7	37	114	180	195	195	280	195	280	200	572	210	605	260	120	130	560	215	24	25	550
8	37	114	180	195	195	285	195	280	200	582	250	710	260	120	190	605	215	24	27	645
9	43	140	215	235	235	330	235	320	230	662	250	710	320	145	155	660	245	28	48	875
10	43	140	215	235	235	350	235	320	230	662	300	810	320	145	205	710	245	28	50	1010
11	47	161	250	270	270	400	270	380	270	782	300	870	370	165	180	805	300	35	80	1460
12	47	161	250	270	270	405	270	380	270	790	300	1025	370	165	265	875	300	35	87	1725

H4.H13 ~ H4.H26

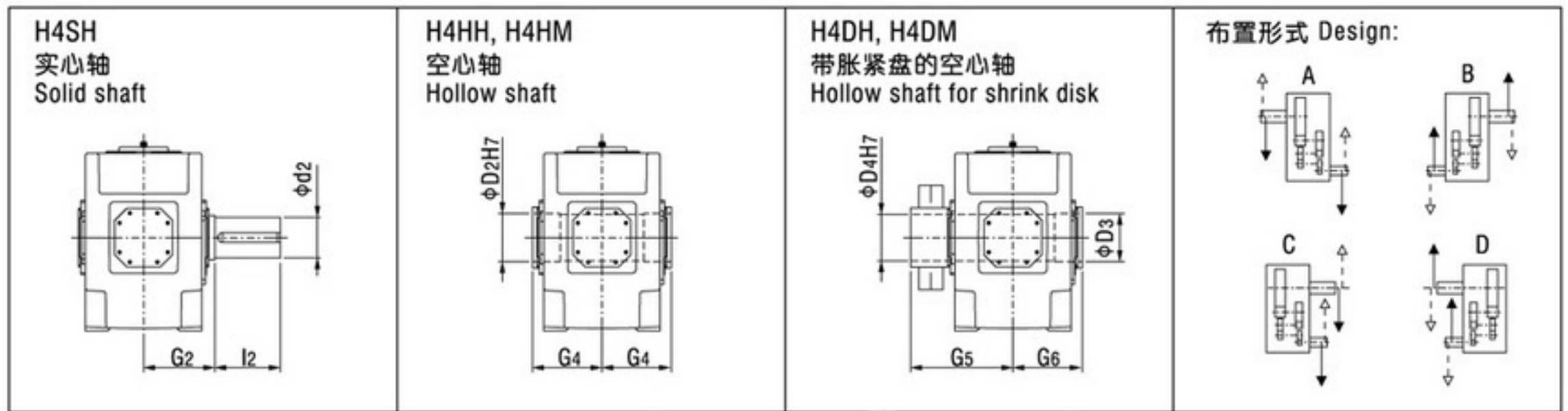
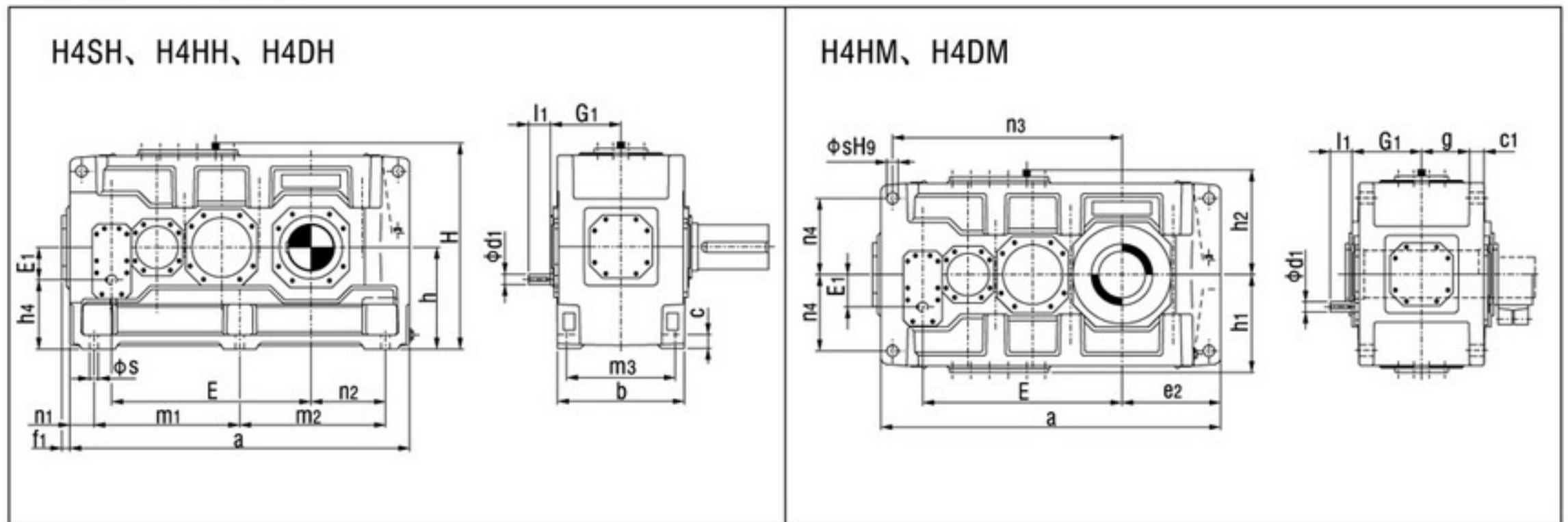

机座号 Size	i _N =100-180		i _N =112-200		i _N =125-224		i _N =200-355		i _N =224-400		i _N =250-450		a	b	c	c1	d2	D2	D3	D4	D5	e2	E	E1
	d1	l1	d1	l1	d1	l1	d1	l1	d1	l1	d1	l1												
13	50	100					38	80					1395	550	60	61 ± 2	200	190	190	190	48	405	820	130
14					50	100					38	80	1535	550	60	61 ± 2	210	210	210	210	48	475	890	130
15	60	135					50	110					1680	625	70	72 ± 2	230	230	230	230	55	485	987	160
16			60	135					50	110			1770	625	70	72 ± 2	240	240	240	240	55	530	1033	160
17	60	105					50	80					1770	690	80	81 ± 2	250	250	250	250	55	525	1035	160
18			60	105					50	80			1890	690	80	81 ± 2	270	275	280	280	55	585	1095	160
19	75	105					60	105					2030	790	90	91 ± 2	290	-	285	285	65	590	1190	185
20			75	105					60	105			2150	790	90	91 ± 2	300	-	310	310	65	650	1250	185
21	90	165					70	140					2340	830	100	100 ± 2	320	-	330	330	75	655	1387	225
22			90	165					70	140			2450	830	100	100 ± 2	340	-	340	340	75	710	1442	225
23	90	130					70	105					2530	930	115	120 ± 2	360	-	360	360	80	730	1505	225
24			90	130					70	105			2660	930	115	120 ± 2	380	-	380	380	80	795	1570	225
25	100	205					85	170					2830	1045	130	120 ± 2	400	-	400	400	90	790	1695	265
26			100	205					85	170			3010	1045	130	120 ± 2	420	-	430	430	90	880	1785	265

机座号 Size	f1	g	G1	G2	G4	G5	G6	h	h1	h2	h4	H	l2	m1	m2	m3	n1	n2	n3	n4	s	润滑油oil (l)		重量weight(kg)	
																						H4.H	H4.M	H4.H	H4.M
13	47	211.5	305	335	335	480	335	440	450	460	310	900	350	597.5	597.5	475	100	305	940	340	35	130	120	2390	2270
14	47	211.5	305	335	335	480	335	440	450	460	310	900	350	597.5	737.5	475	100	375	1010	340	35	140	125	2730	2600
15	56	238	345	380	380	550	380	500	490	500	340	1000	410	720	720	535	120	365	1135	375	42	230	170	3635	3440
16	56	238	345	380	380	550	380	500	490	500	340	1000	410	720	810	535	120	410	1180	375	42	235	175	3965	3740
17	53	259	380	415	415	600	415	550	555	560	390	1110	410	750	750	600	135	390	1175	425	42	290	225	4680	4445
18	53	259	380	415	415	600	415	550	555	560	390	1110	470	750	870	600	135	450	1235	425	42	305	230	5185	4915
19	53	299	440	465	-	670	465	620	615	620	435	1240	470	860	860	690	155	435	1365	475	48	360	310	6800	6300
20	53	299	440	465	-	670	465	620	615	620	435	1240	500	860	980	690	155	495	1425	475	48	380	330	8200	7700
21	62	310	460	490	-	715	490	700	685	690	475	1390	500	1000	1000	720	170	485	1600	520	56	395	430	9200	8600
22	62	310	460	490	-	725	490	700	685	690	475	1390	550	1000	1110	720	170	540	1655	520	56	420	450	9900	9400
23	35	342	505	540	-	785	540	780	770	790	555	1570	590	1085	1085	810	180	550	1725	580	56	520	500	11600	10700
24	35	342	505	540	-	805	540	780	770	790	555	1570	590	1085	1215	810	180	615	1790	580	56	550	600	13500	12600
25	65	400	565	605	-	875	605	860	860	860	595	1720	650	1215	1215	910	200	590	1965	660	66	735	800	16100	15200
26	65	400	565	605	-	900	605	860	860	860	595	1720	650	1215	1395	910	200	680	2055	660	66	780	850	17600	16500

B2.H4 ~ B2.H12

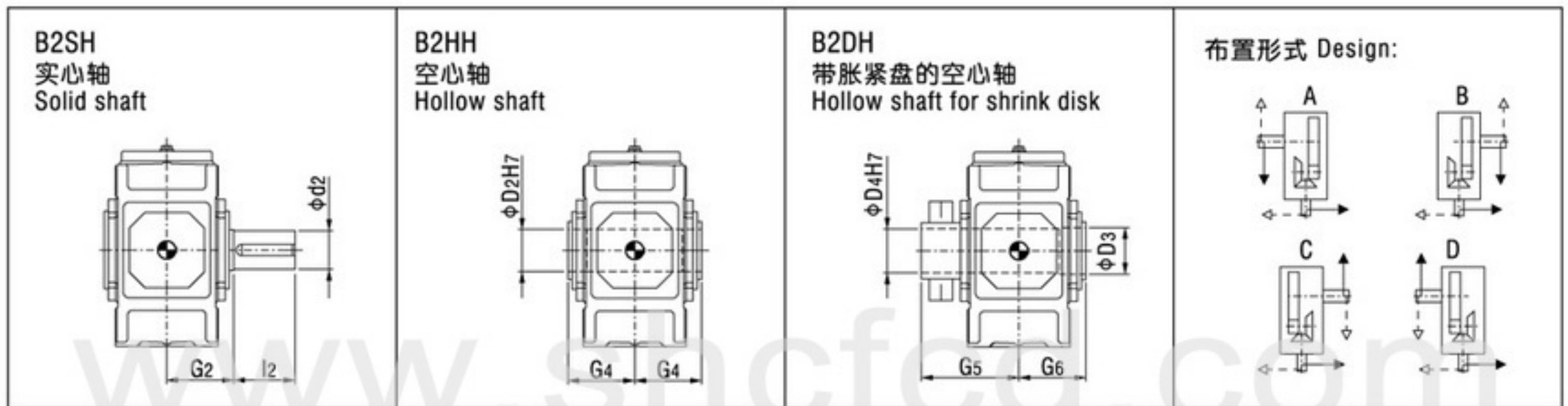
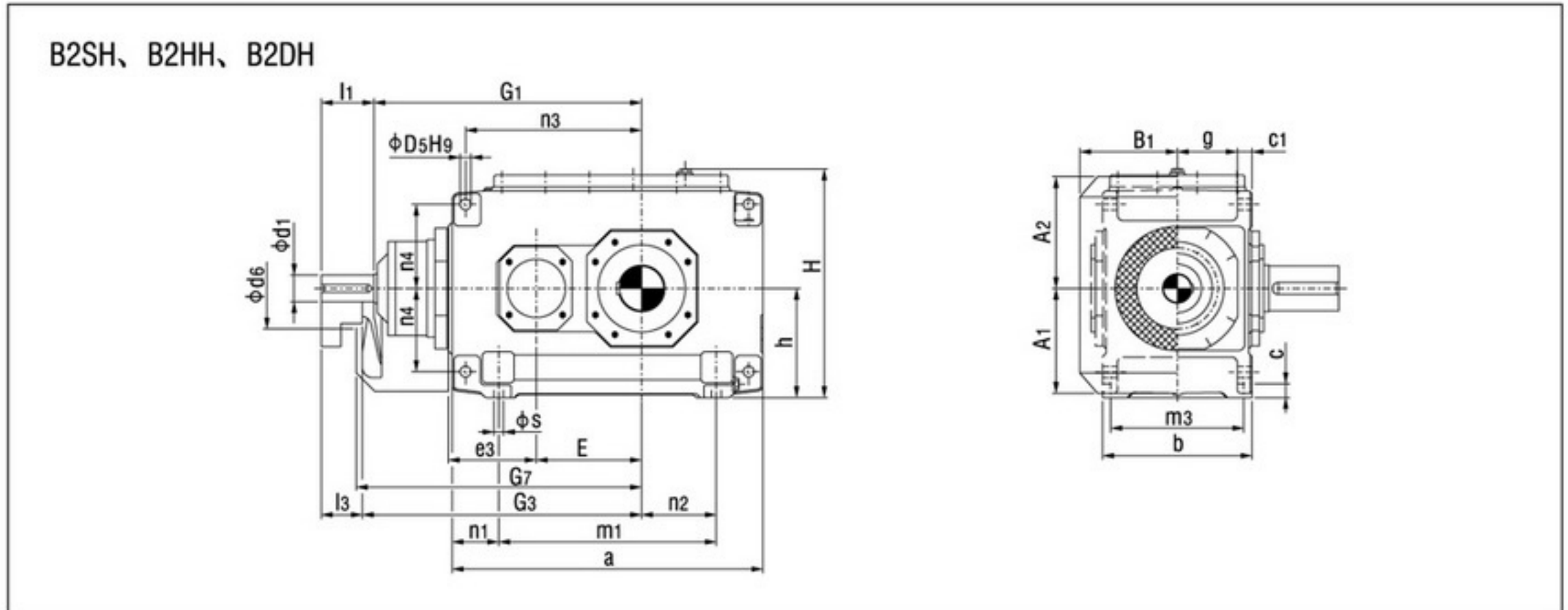

机座号 Size	i _N = 5 - 11.2			i _N = 6.3 - 14			a	A1	A2	b	B1	c	c1	d2	d6	D2	D3	D4	D5	e3	E
	d1	l1	l3	d1	l1	l3															
4	50	100	80				505	195	200	270	188	28	30±1	80	150	80	85	85	24	160	160
5	60	110	80				565	220	235	320	215	28	30±1	100	160	95	100	100	24	185	185
6				60	110	80	645	220	235	320	215	28	30±1	110	160	105	110	110	24	185	220
7	75	135	105				690	270	285	380	250	35	36±1	120	210	115	120	120	28	225	225
8				75	135	105	795	270	285	380	250	35	36±1	130	210	125	130	130	28	225	270
9	85	165	130				820	310	325	440	270	40	48±1.5	140	195	135	140	140	36	265	265
10				85	165	130	920	310	325	440	270	40	48±1.5	160	195	150	150	150	36	265	315
11	95	165	130				975	370	385	530	328	50	54±1.5	170	210	165	165	165	40	320	320
12				95	165	130	1130	370	385	530	328	50	54±1.5	180	210	180	180	180	40	320	390

机座号 Size	g	G1	G2	G3	G4	G5	G6	G7	h	H	l2	m1	m3	n1	n2	n3	n4	s	润滑油oil (l)		重量 weight (kg)
																			(1)*	(2)*	
4	105	465	170	485	170	235	170	495	200	415	170	295	235	105	85	285	150	19	10	-	235
5	130	535	200	565	200	275	200	575	230	482	210	355	285	105	100	330	180	19	16	14	360
6	130	570	200	600	200	275	200	610	230	482	210	435	285	105	145	365	180	19	19	15	410
7	154	640	235	670	235	320	235	685	280	582	210	450	340	120	130	405	215	24	31	28	615
8	154	685	235	715	235	325	235	730	280	582	250	555	340	120	190	450	215	24	34	29	700
9	172	755	270	790	270	365	270	805	320	662	250	530	390	145	155	480	245	28	48	38	1000
10	172	805	270	840	270	385	270	855	320	662	300	630	390	145	205	530	245	28	50	40	1155
11	211	925	320	960	320	450	320	980	380	790	300	645	470	165	180	580	300	35	80	65	1640
12	211	995	320	1030	320	455	320	1050	380	790	300	800	470	165	265	650	300	35	95	71	1910

(1)*轴封；(2)*迷宫式密封。

(1)*Shaft seal, (2)*Labyrinth seal.

B2.H13 ~ B2.H18

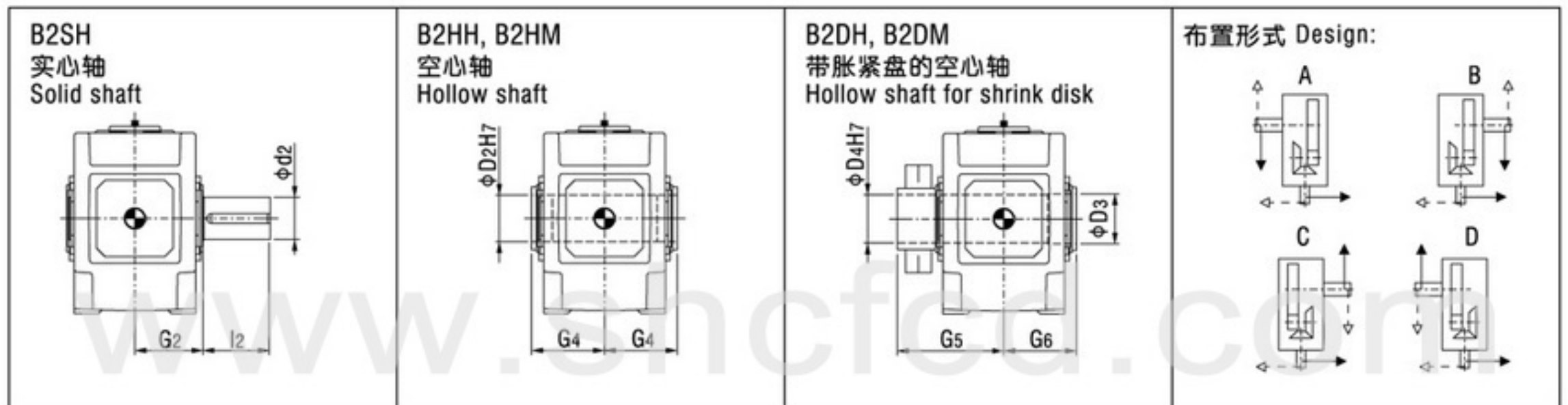
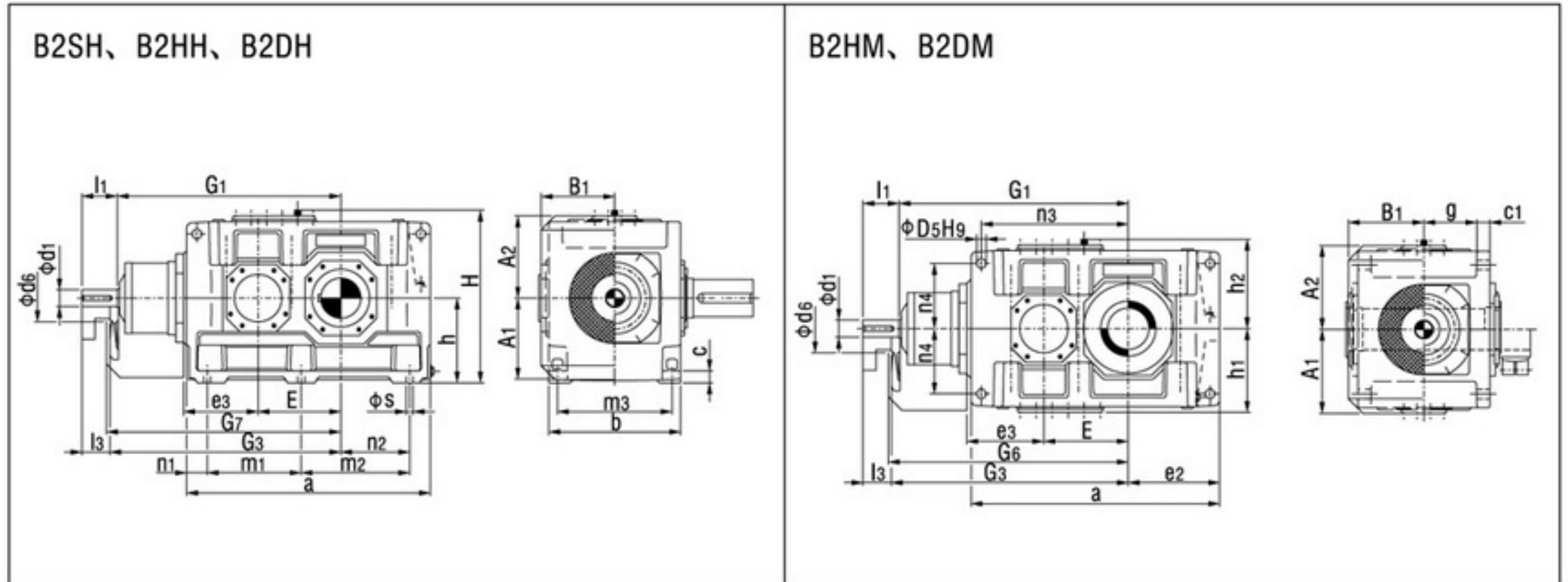

机座号 Size	$i_N=5-11.2$			$i_N=5.6-11.2$			$i_N=5.6-12.5$			$i_N=6.3-14$			$i_N=7.1-12.5$			a	A1	A2	b	B1	c	c1	d2	d6	D2	D3	D4	D5	e2	e3
	d1	l1	l3	d1	l1	l3	d1	l1	l3	d1	l1	l3	d1	l1	l3															
13	115	205	165												1130	430	450	655	375	60	61 ± 2	200	245	-	-	-	48	405	380	
14									115	205	165				1270	430	450	655	375	60	61 ± 2	210	245	210	210	210	48	475	380	
15	140	245	200												1350	490	495	765	435	70	72 ± 2	230	280	-	-	-	55	485	450	
16							140	245	200						1440	490	495	765	435	70	72 ± 2	240	280	240	240	240	55	530	450	
17				150	245	200									1490	540	555	885	505	80	81 ± 2	250	380	-	-	-	65	525	510	
18												150	245	200	1610	540	555	885	505	80	81 ± 2	270	380	275	280	280	65	585	510	

机座号 Size	E	g	G1	G2	G3	G4	G5	G6	G7	h	h1	h2	H	l2	m1	m2	m3	n1	n2	n3	n4	s	润滑油oil (l)			重量 weight (kg)	
																							B2.H		B2.M	B2.H	B2.M
																							(1)*	(2)*			
13	370	264	1070	390	1110	-	-	-	1130	440	450	460	900	350	465	465	580	100	305	675	340	35	140	125	120	2450	2350
14	440	264	1140	390	1180	390	535	390	1200	440	450	460	900	350	465	605	580	100	375	745	340	35	155	140	130	2825	2725
15	442	308	1277	460	1322	-	-	-	1340	500	490	500	1000	410	555	555	670	120	365	805	375	42	220	195	180	3990	3795
16	488	308	1323	460	1368	450	620	450	1385	500	490	500	1000	410	555	645	670	120	410	850	375	42	230	205	190	4345	4160
17	490	356	1435	540	1480	-	-	-	1500	550	555	560	1110	410	610	610	780	135	390	895	420	48	320	280	260	5620	5320
18	550	356	1495	540	1540	510	700	510	1560	550	555	560	1110	470	610	730	780	135	450	955	420	48	335	300	275	6150	5860

(1)*轴封; (2)*迷宫式密封。

(1)*Shaft seal, (2)*Labyrinth seal.

B3.H4 ~ B3.H12

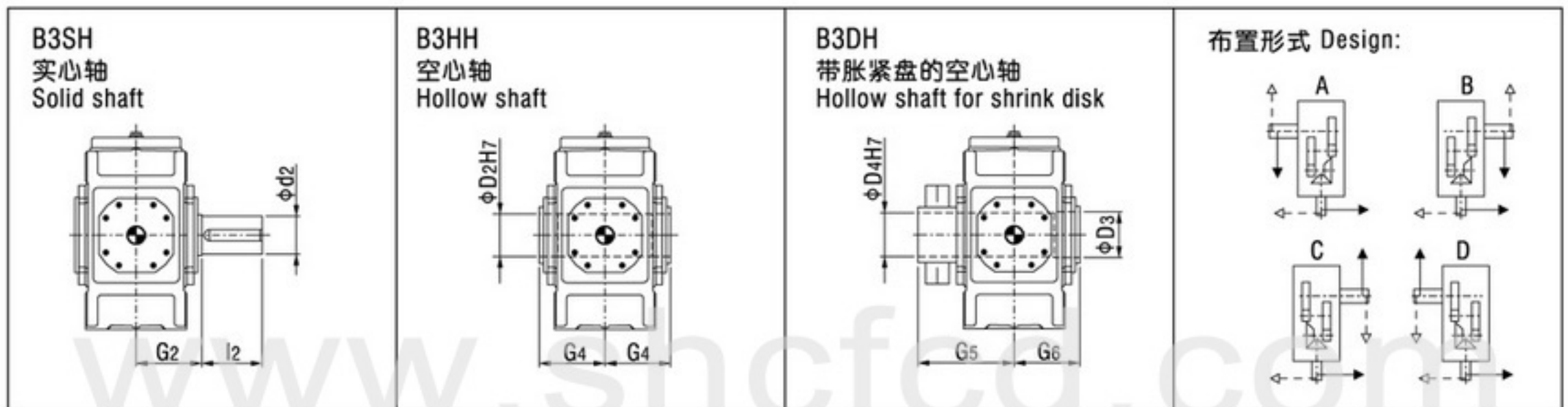
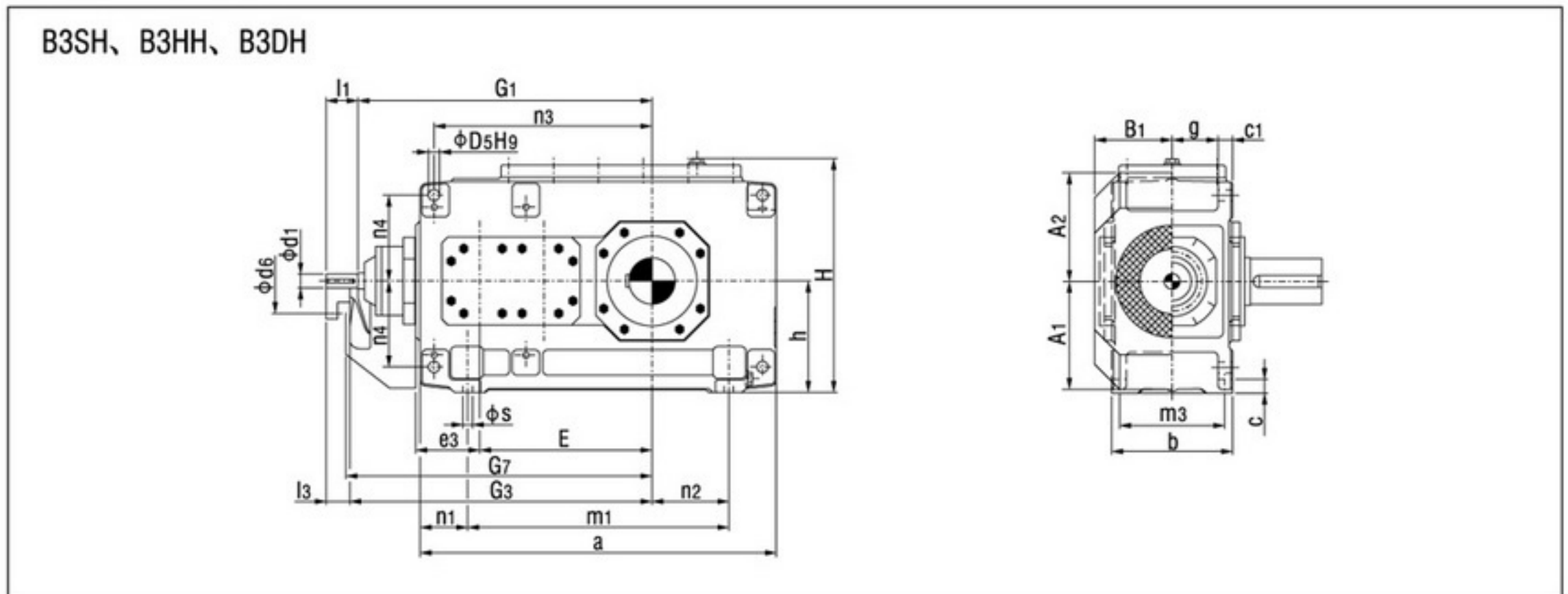

机座号 Size	$i_N = 12.5 - 45$			$i_N = 16 - 56$			$i_N = 50 - 71$			$i_N = 63 - 90$			a	A1	A2	b	B1	c	c1	d2	d6	D2	D3	D4
	d1	l1	l3	d1	l1	l3	d1	l1	l3	d1	l1	l3												
4	35	70	50				30	60	40				565	195	200	215	143	28	30 ± 1	80	110	80	85	85
5	45	80	60				35	60	40				640	220	235	255	168	28	30 ± 1	100	130	95	100	100
6				45	80	60				35	60	40	720	220	235	255	168	28	30 ± 1	110	130	105	110	110
7	50	100	80				40	80	60				785	275	275	300	193	35	36 ± 1	120	165	115	120	120
8				50	100	80				40	80	60	890	275	275	300	193	35	36 ± 1	130	165	125	130	130
9	60	110	80				50	100	70				925	315	325	370	231	40	45 ± 1.5	140	175	135	140	140
10				60	110	80				50	100	70	1025	315	325	370	231	40	45 ± 1.5	160	175	150	150	150
11	75	135	105				60	110	80				1105	370	385	430	263	50	54 ± 1.5	170	190	165	165	165
12				75	135	105				60	110	80	1260	370	385	430	263	50	54 ± 1.5	180	190	180	180	180

机座号 Size	D5	e3	E	g	G1	G2	G3	G4	G5	G6	G7	h	h5	H	l2	m1	m3	n1	n2	n3	n4	s	润滑油oil (l)	重量 weight (kg)
4	24	110	270	77.5	500	140	520	140	205	140	530	200	100	415	170	355	180	105	85	345	150	19	9	210
5	24	130	315	97.5	575	165	595	165	240	165	605	230	130	482	210	430	220	105	100	405	180	19	14	325
6	24	130	350	97.5	610	165	630	165	240	165	640	230	130	482	210	510	220	105	145	440	180	19	15	380
7	28	160	385	114	690	195	710	195	280	195	720	280	170	572	210	545	260	120	130	500	215	24	25	550
8	28	160	430	114	735	195	755	195	285	195	765	280	160	582	250	650	260	120	190	545	215	24	28	635
9	36	185	450	140	800	235	830	235	330	235	845	320	175	662	250	635	320	145	155	585	245	28	40	890
10	36	185	500	140	850	235	880	235	350	235	895	320	175	662	300	735	320	145	205	635	245	28	42	1020
11	40	225	545	161	960	270	990	270	400	270	1010	380	220	782	300	775	370	165	180	710	300	35	66	1455
12	40	225	615	161	1030	270	1060	270	405	270	1080	380	210	790	300	930	370	165	265	780	300	35	72	1730

B3.H13 ~ B3.H26

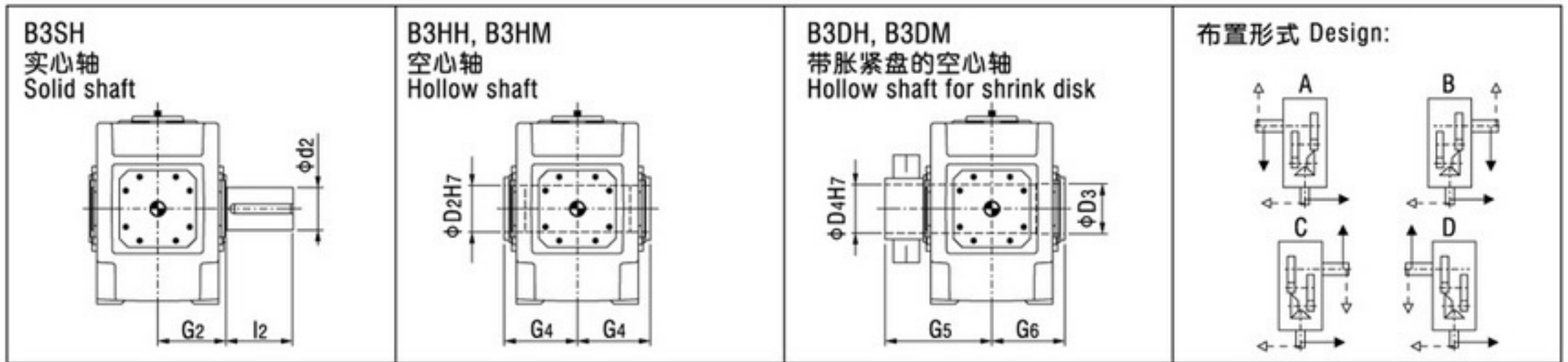
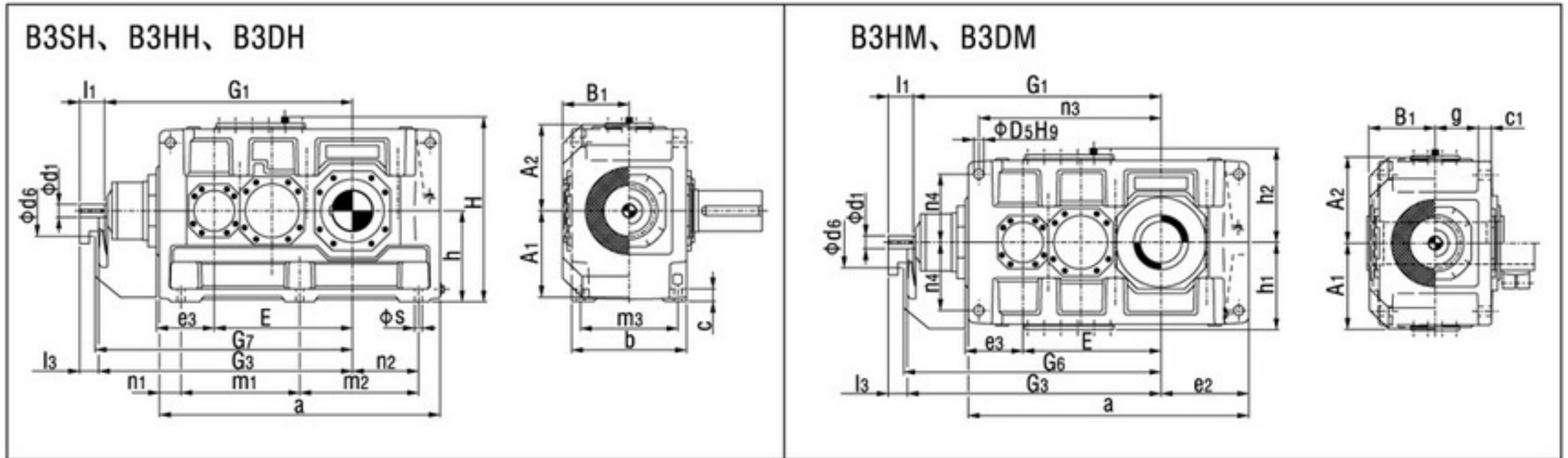

机座号 Size	$i_N=12.5-45$			$i_N=14-50$			$i_N=16-56$			$i_N=50-71$			$i_N=56-80$			$i_N=63-90$			a	A1	A2	b	B1	c	c1	d2	d6	D2	D3	D4
	d1	l1	l3	d1	l1	l3	d1	l1	l3	d1	l1	l3	d1	l1	l3	d1	l1	l3												
13	85	165	130						70	140	105								1290	425	435	550	325	60	61 ± 2	200	210	190	190	190
14							85	165	130							70	140	105	1430	425	435	550	325	60	61 ± 2	210	210	210	210	210
15	95	165	130							75	140	105							1550	485	520	625	365	70	72 ± 2	230	210	230	230	230
16				95	165	130							75	140	105				1640	485	520	625	365	70	72 ± 2	240	210	240	240	240
17	115	205	165							90	170	130							1740	535	570	690	395	80	81 ± 2	250	230	250	250	250
18				115	205	165							90	170	130				1860	535	570	690	395	80	81 ± 2	270	230	275	280	280
19	140	245	200							110	210	165							2010	610	630	790	448	90	91 ± 2	290	245	-	285	285
20				140	245	200							110	210	165				2130	610	630	790	448	90	91 ± 2	300	245	-	310	310
21	140	245	200							110	210	165							2140	690	690	830	473	100	100 ± 2	320	280	-	330	330
22				140	245	200							110	210	165				2250	690	690	830	473	100	100 ± 2	340	280	-	340	340
23	150	245	200							115	210	165							2380	770	770	930	528	115	120 ± 2	360	350	-	360	360
24				150	245	200							115	210	165				2510	770	770	930	528	115	120 ± 2	380	350	-	380	380
25	150	245	200							115	210	165							2580	845	865	1045	585	130	120 ± 2	400	380	-	400	400
26				150	245	200							115	210	165				2760	845	865	1045	585	130	120 ± 2	420	380	-	430	430

机座号 Size	D5	e2	e3	E	g	G1	G2	G3	G4	G5	G6	G7	h	h1	h2	H	l2	m1	m2	m3	n1	n2	n3	n4	s	润滑油oil (l)		重量 weight (kg)	
																										B3.H	B3.M	B3.H	B3.M
13	48	405	265	635	211.5	1125	335	1160	335	480	335	1180	440	450	460	900	350	545	545	475	100	305	835	340	35	130	110	2380	2260
14	48	475	265	705	211.5	1195	335	1230	335	480	335	1250	440	450	460	900	350	545	685	475	100	375	905	340	35	140	115	2750	2615
15	55	485	320	762	238	1367	380	1402	380	550	380	1420	500	490	500	1000	410	655	655	535	120	365	1005	375	42	210	160	3730	3540
16	55	530	320	808	238	1413	380	1448	380	550	380	1470	500	490	500	1000	410	655	745	535	120	410	1050	375	42	220	165	3955	3765
17	55	525	370	860	259	1560	415	1600	415	600	415	1620	550	555	560	1110	410	735	735	600	135	390	1145	425	42	290	230	4990	4760
18	55	585	370	920	259	1620	415	1660	415	600	415	1680	550	555	560	1110	470	735	855	600	135	450	1205	425	42	300	235	5495	5240
19	65	590	420	997	299	1832	465	1877	-	670	465	1900	620	615	620	1240	470	850	850	690	155	435	1345	475	48	380	360	7000	6500
20	65	650	420	1057	299	1892	465	1937	-	670	465	1960	620	615	620	1240	500	850	970	690	155	495	1405	475	48	440	420	8100	7600
21	75	655	450	1067	310	1902	490	1947	-	715	490	1970	700	685	690	1390	500	900	900	720	170	485	1400	520	56	370	420	9200	8600
22	75	710	450	1122	310	1957	490	2002	-	725	490	2025	700	685	690	1390	550	900	1010	720	170	540	1455	520	56	430	490	9900	9400
23	80	730	490	1185	342	2130	540	2175	-	785	540	2200	780	770	790	1570	590	1010	1010	810	180	550	1560	580	56	520	560	11500	10600
24	80	795	490	1250	342	2195	540	2240	-	805	540	2265	780	770	790	1570	590	1010	1140	810	180	615	1625	580	56	600	650	13400	12500
25	90	790	490	1325	400	2270	605	2315	-	875	605	2315	860	860	860	1720	650	1090	1090	910	200	590	1685	660	66	720	790	16000	15100
26	90	880	490	1415	400	2360	605	2405	-	900	605	2430	860	860	860	1720	650	1090	1270	910	200	680	1775	660	66	840	920	17500	16400

B4.H5 ~ B4.H12

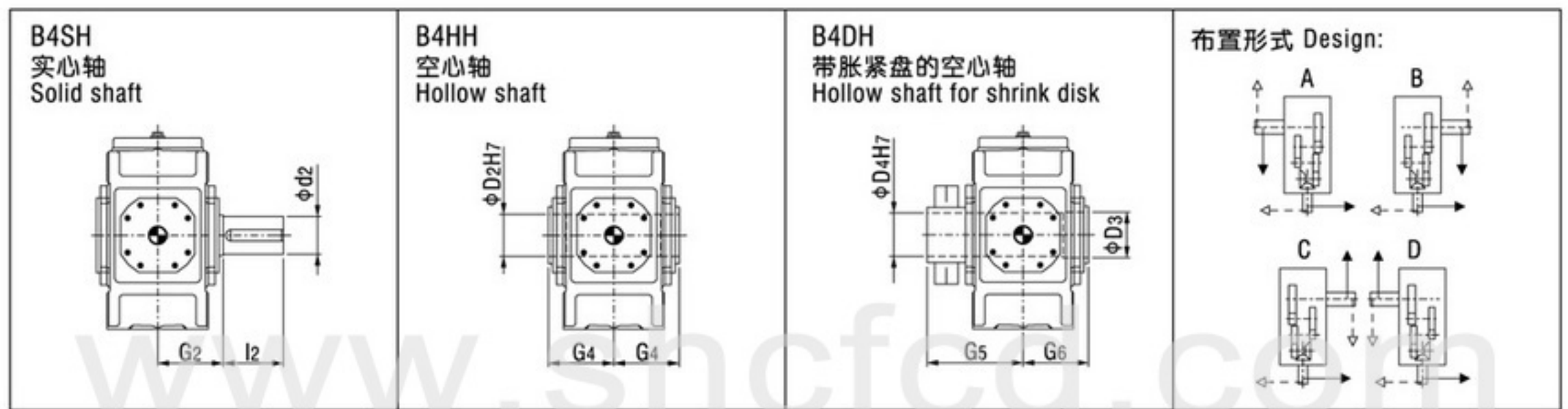
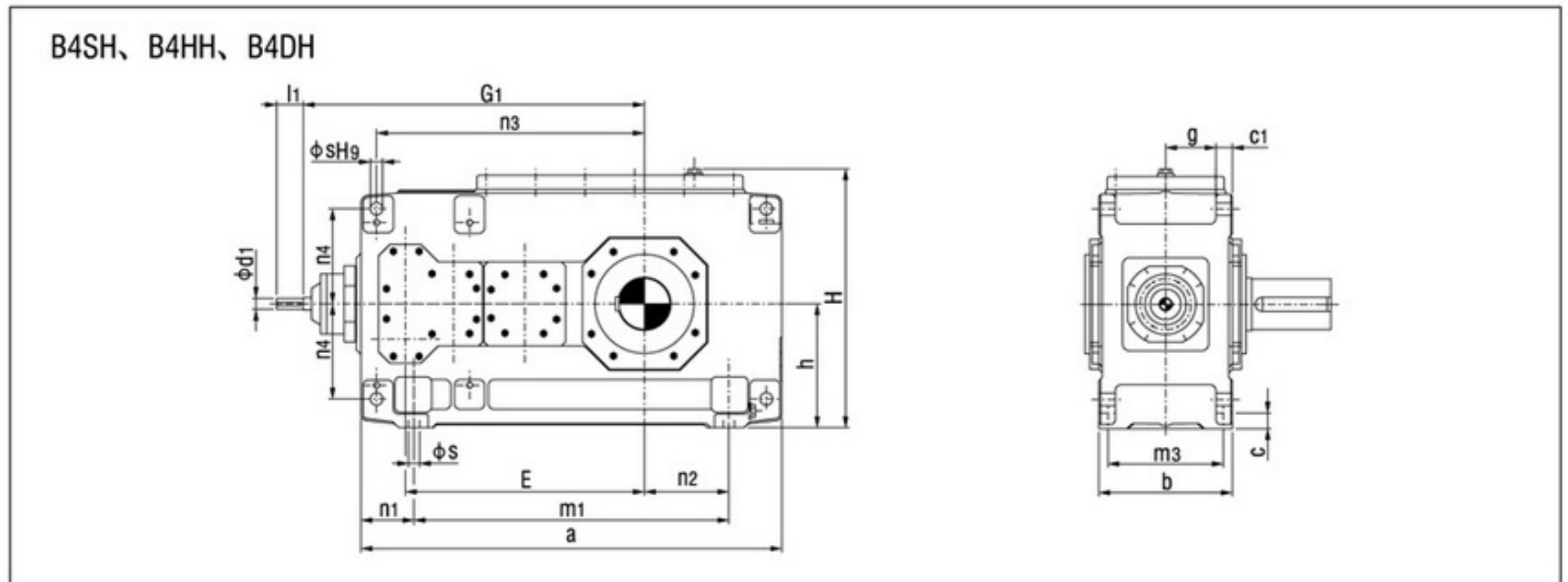

机座号 Size	$i_N = 80 - 180$		$i_N = 100 - 224$		$i_N = 200 - 315$		$i_N = 250 - 400$		a	b	c	c1	d2	D2	D3	D4	D5	E	g
	d1	l1	d1	l1	d1	l1	d1	l1											
5	35	55			25	50			690	255	28	30±1	100	95	100	100	24	405	97.5
6			35	55			25	50	770	255	28	30±1	110	105	110	110	24	440	97.5
7	35	70			30	60			845	300	35	36±1	120	115	120	120	28	495	114
8			35	70			30	60	950	300	35	36±1	130	125	130	130	28	540	114
9	45	80			35	60			1000	370	40	45±1.5	140	135	140	140	36	580	140
10			45	80			35	60	1100	370	40	45±1.5	160	150	150	150	36	630	140
11	50	100			40	80			1200	430	50	54±1.5	170	165	165	165	40	705	161
12			50	100			40	80	1355	430	50	54±1.5	180	180	180	180	40	775	161

机座号 Size	G1	G2	G4	G5	G6	h	h5	H	l2	m1	m3	n1	n2	n3	n4	s	润滑油oil (l)	重量 weight (kg)
5	615	165	165	240	165	230	100	482	210	480	220	105	100	455	180	19	16	335
6	650	165	165	240	165	230	100	482	210	560	220	105	145	490	180	19	18	385
7	725	195	195	280	195	280	140	572	210	605	260	120	130	560	215	24	30	555
8	770	195	195	285	195	280	130	582	250	710	260	120	190	605	215	24	33	655
9	840	235	235	330	235	320	135	662	250	710	320	145	155	660	245	28	48	890
10	890	235	235	350	235	320	135	662	300	810	320	145	205	710	245	28	50	1025
11	1010	270	270	400	270	380	170	782	300	870	370	165	180	805	300	35	80	1485
12	1080	270	270	405	270	380	160	790	300	1025	370	165	265	875	300	35	90	1750

B4.H13 ~ B4.H26

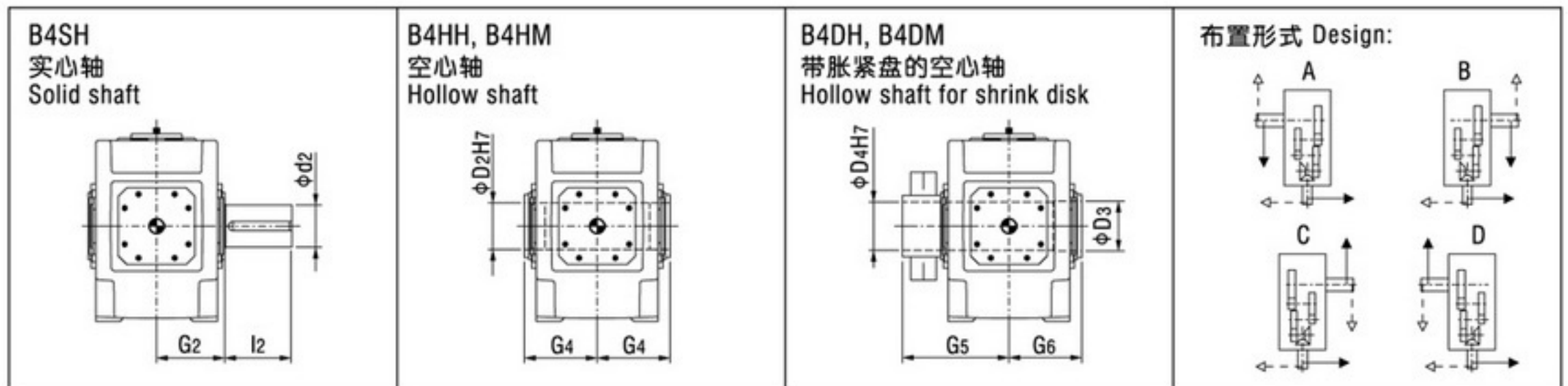
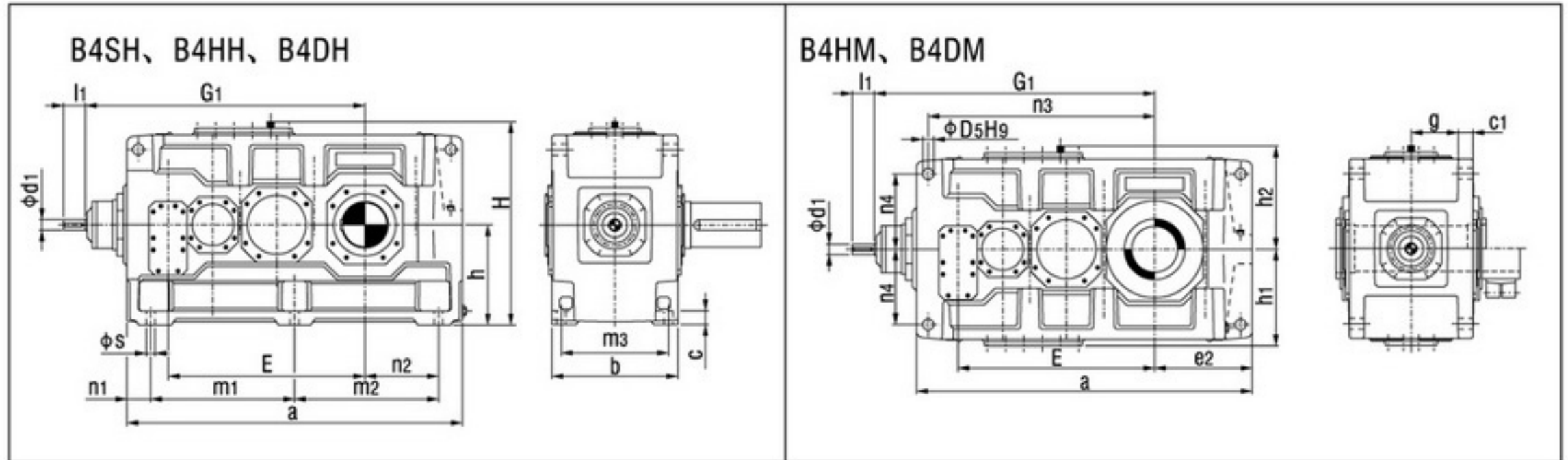

机座号 Size	$i_N = 80-180$		$i_N = 90-200$		$i_N = 100-224$		$i_N = 200-315$		$i_N = 224-355$		$i_N = 250-400$		a	b	c	c1	d2	D2	D3	D4	D5
	d1	l1	d1	l1	d1	l1	d1	l1	d1	l1	d1	l1									
13	60	110					50	100					1395	550	60	61 ± 2	200	190	190	190	48
14					60	110					50	100	1535	550	60	61 ± 2	210	210	210	210	48
15	75	135					60	110					1680	625	70	72 ± 2	230	230	230	230	55
16			75	135					60	110			1770	625	70	72 ± 2	240	240	240	240	55
17	75	135					60	110					1770	690	80	81 ± 2	250	250	250	250	55
18			75	135					60	110			1890	690	80	81 ± 2	270	275	280	280	55
19	85	165					70	140					2030	790	90	91 ± 2	290	-	285	285	65
20			85	165					70	140			2150	790	90	91 ± 2	300	-	310	310	65
21	95	165					75	140					2340	830	100	100 ± 2	320	-	330	330	75
22			95	165					75	140			2450	830	100	100 ± 2	340	-	340	340	75
23	95	165					75	140					2530	930	115	120 ± 2	360	-	360	360	80
24			95	165					75	140			2660	930	115	120 ± 2	380	-	380	380	80
25	115	205					90	170					2830	1045	130	120 ± 2	400	-	400	400	90
26			115	205					90	170			3010	1045	130	120 ± 2	420	-	430	430	90

机座号 Size	G1	e2	E	g	G2	G4	G5	G6	h	h1	h2	H	l2	m1	m2	m3	n1	n2	n3	n4	s	润滑油oil (l)		重量weight (kg)	
																						B4.H	B4.M	B4.H	B4.M
13	1170	405	820	211.5	335	335	480	335	440	450	460	900	350	597.5	597.5	475	100	305	940	340	35	145	120	2395	2280
14	1240	475	890	211.5	335	335	480	335	440	450	460	900	350	597.5	737.5	475	100	375	1010	340	35	150	125	2735	2605
15	1402	485	987	238	380	380	550	380	500	490	500	1000	410	720	720	535	120	365	1135	375	42	230	170	3630	3435
16	1448	530	1033	238	380	380	550	380	500	490	500	1000	410	720	810	535	120	410	1180	375	42	235	175	3985	3765
17	1450	525	1035	259	415	415	600	415	550	555	560	1110	410	750	750	600	135	390	1175	425	42	295	230	4695	4460
18	1510	585	1095	259	415	415	600	415	550	555	560	1110	470	750	870	600	135	450	1235	425	42	305	235	5200	4930
19	1680	590	1190	299	465	-	670	465	620	615	620	1240	470	860	860	690	155	435	1365	475	48	480	440	6800	6300
20	1740	650	1250	299	465	-	670	465	620	615	620	1240	500	860	980	690	155	495	1425	475	48	550	510	8200	7700
21	1992	655	1387	310	490	-	715	490	700	685	690	1390	500	1000	1000	720	170	485	1600	520	56	540	590	9200	8600
22	2047	710	1442	310	490	-	725	490	700	685	690	1390	550	1000	1110	720	170	540	1655	520	56	620	680	9900	9400
23	2110	730	1505	342	540	-	785	540	780	770	790	1570	590	1085	1085	810	180	550	1725	580	56	710	790	11600	10700
24	2175	795	1570	342	540	-	805	540	780	770	790	1570	590	1085	1215	810	180	615	1790	580	56	810	910	13500	12600
25	2395	790	1695	400	605	-	875	605	860	860	860	1720	650	1215	1215	910	200	590	1965	660	66	1000	1110	16100	15200
26	2485	880	1785	400	605	-	900	605	860	860	860	1720	650	1215	1395	910	200	680	2055	660	66	1100	1200	17600	16500

H2.V4 ~ H2.V12

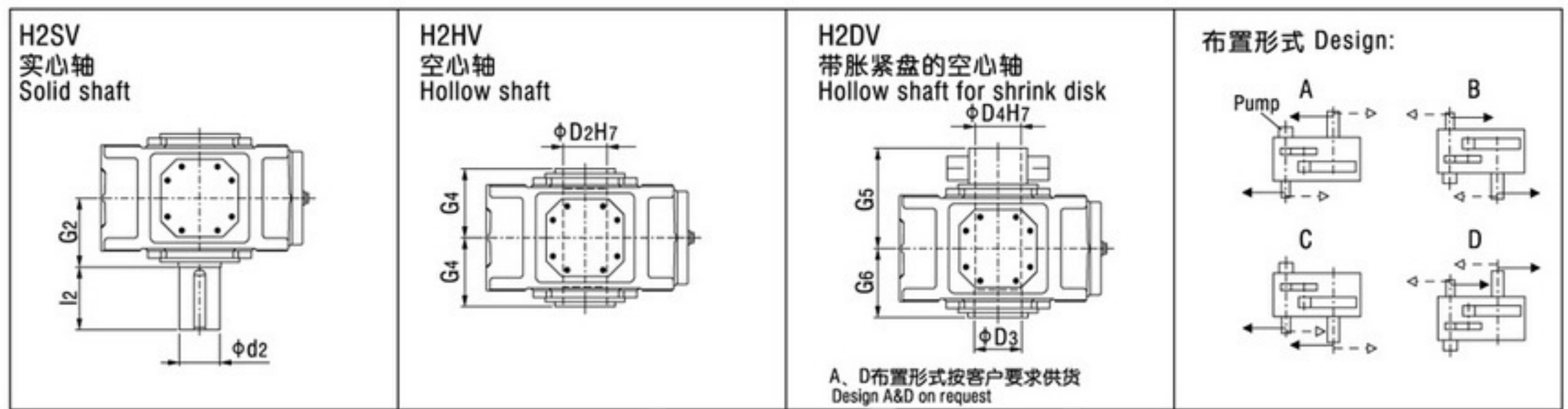
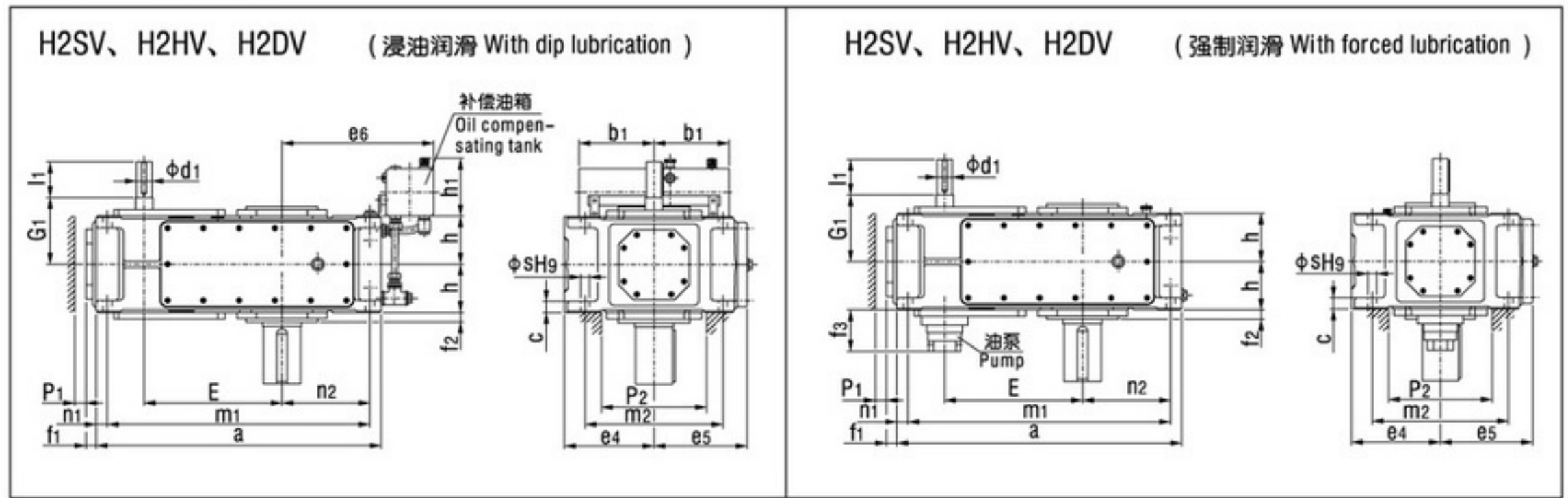

机座号 Size	$i_N = 6.3 - 11.2$		$i_N = 8 - 14$		$i_N = 12.5 - 22.4$		$i_N = 16 - 28$		a	b1	c	d2	D2	D3	D4	e4	e5	e6	E
	d1	l1	d1	l1	d1	l1	d1	l1											
4	45	100			32	80			565	150	30 ± 1	80	80	85	85	200	215	320	270
5	50	100			38	80			640	240	30 ± 1	100	95	100	100	230	252	385	315
6			50	100			38	80	720	240	30 ± 1	110	105	110	110	230	252	425	350
7	60	135			50	110			785	240	36 ± 1	120	115	120	120	280	292	425	385
8			60	135			50	110	890	240	36 ± 1	130	125	130	130	280	302	485	430
9	75	140			60	140			925	330	45 ± 1.5	140	135	140	140	320	342	560	450
10			75	140			60	140	1025	330	45 ± 1.5	160	150	150	150	320	342	610	500
11	90	165			70	140			1105	330	54 ± 1.5	170	165	165	165	380	402	595	545
12			90	165			70	140	1260	330	54 ± 1.5	180	180	180	180	380	410	680	615

机座号 Size	f1	f2	f3	G1	G2	G4	G5	G6	h	h1	l2	m1	m2	n1	n2	P1	P2	s	润滑油oil (l)		重量weight (kg)
																			(1)**	(2)**	
4	28	22	-	170	140	140	205	140	107.5	165	170	505	300	30	160	35	220	24	25	-	190
5	38	28	150	195	165	165	240	165	127.5	205	210	580	360	30	175	35	270	24	23	10	300
6	38	28	150	195	165	165	240	165	127.5	205	210	660	360	30	220	35	270	24	27	11	355
7	42	30	145	210	195	195	280	195	150	205	210	715	430	35	215	35	330	28	58	22	505
8	42	32	145	210	195	195	285	195	150	205	250	820	430	35	275	35	330	28	62	25	590
9	42	32	135	240	235	235	330	235	185	275	250	845	490	40	260	40	370	36	100	42	830
10	42	32	135	240	235	235	350	235	185	275	300	945	490	40	310	40	370	36	110	46	960
11	48	35	145	275	270	270	400	270	215	275	300	1005	600	50	295	50	440	40	160	60	1335
12	48	35	145	275	270	270	405	270	215	275	300	1160	600	50	380	50	440	40	180	70	1615

(1)**浸油润滑; (2)**强制润滑。

(1)**Dip lubrication, (2)**Forced lubrication.

H2.V13 ~ H2.V22

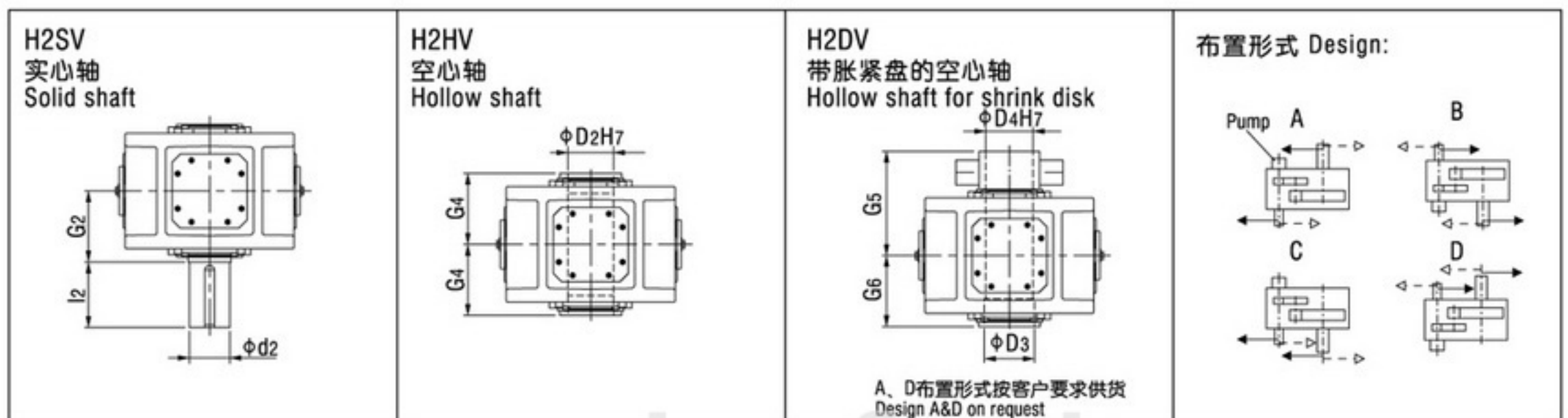
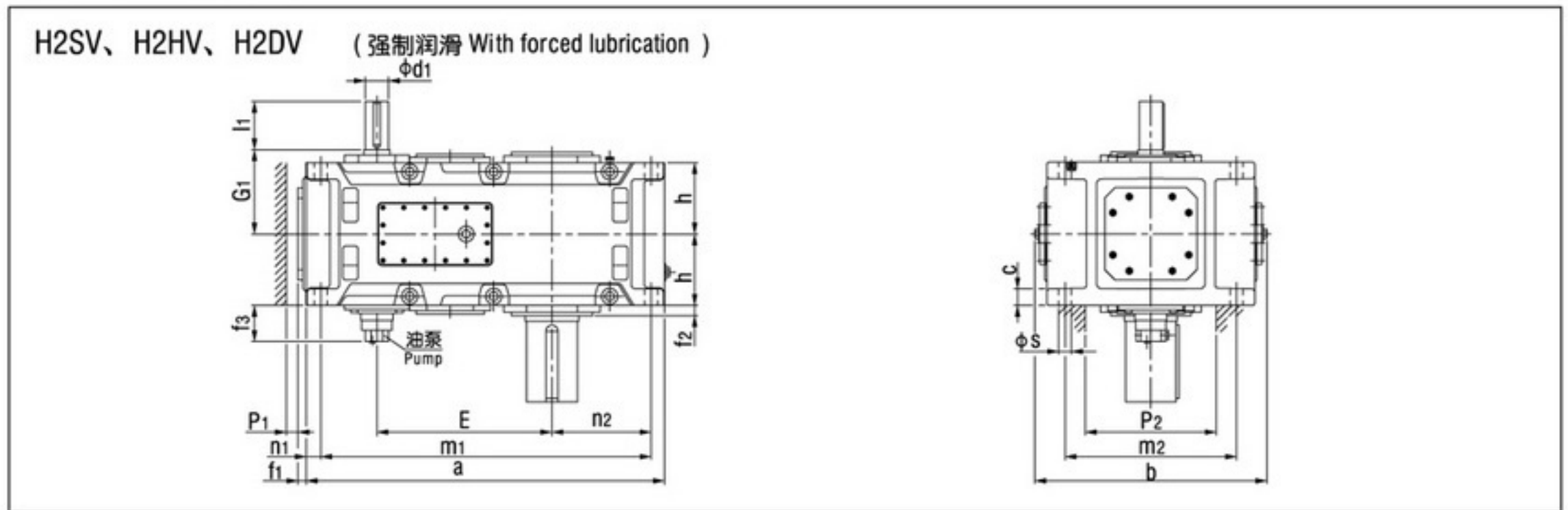

机座号 Size	$i_N = 6.3 - 11.2$		$i_N = 7.1 - 12.5$		$i_N = 8 - 14$		$i_N = 12.5 - 20$		$i_N = 14 - 22.4$		$i_N = 16 - 25$		a	b	c	d2	D2	D3	D4	E
	d1	l1	d1	l1	d1	l1	d1	l1	d1	li	d1	li								
13	100	205					85	170					1290	900	61 ± 2	200	190	190	190	635
14					100	205					85	170	1430	900	61 ± 2	210	210	210	210	705
15	120	210					100	210					1550	980	72 ± 2	230	230	230	230	762
16			120	210					100	210			1640	980	72 ± 2	240	240	240	240	808
17	125	245					110	210					1740	1110	81 ± 2	250	250	250	250	860
18			125	245					110	210			1860	1110	81 ± 2	270	275	280	280	920
19	按客户要求供货 On request																			
20																				
21																				
22																				

机座号 Size	f1	f2	f3	G1	G2	G4	G5	G6	h	l2	m1	m2	n1	n2	P1	P2	s	润滑油oil (l)	重量 weight (kg)
13	53	35	130	330	335	335	480	335	272.5	350	1195	680	50	360	50	500	48	80	1880
14	53	35	130	330	335	335	480	335	272.5	350	1335	680	50	430	50	500	48	90	2430
15	63	42	130	365	380	380	550	380	310	410	1435	750	60	430	50	570	55	140	3240
16	63	42	130	365	380	380	550	380	310	410	1525	750	60	475	50	570	55	150	3465
17	60	42	170	420	415	415	600	415	340	410	1610	850	70	465	70	630	55	175	4420
18	60	42	170	420	415	415	600	415	340	470	1730	850	70	525	70	630	55	185	4870
19	按客户要求供货 On request																		
20																			
21																			
22																			

H3.V5 ~ H3.V12

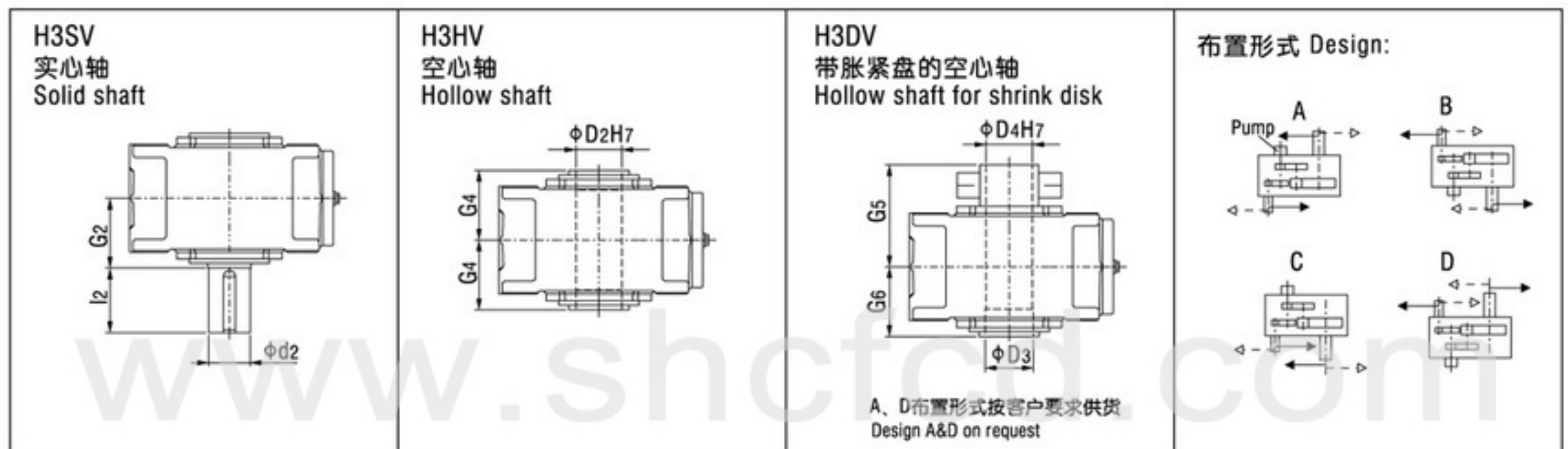
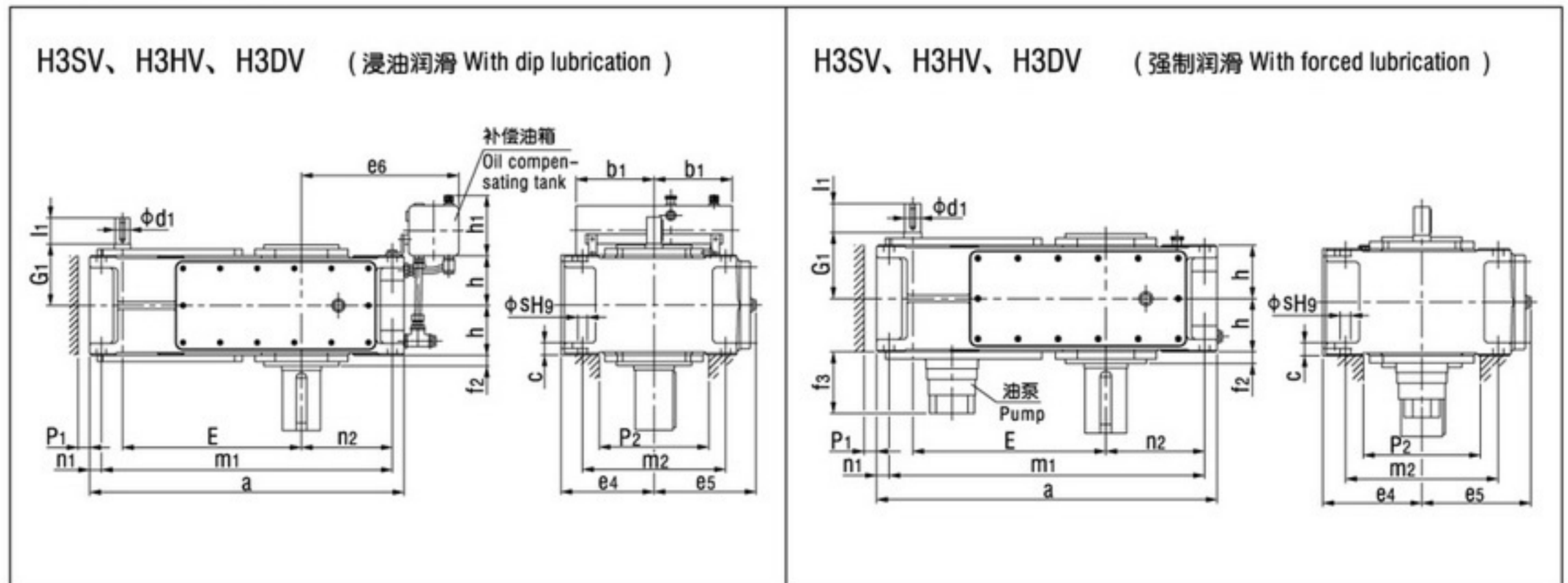

机座号 Size	$i_N = 25 - 45$		$i_N = 31.5 - 56$		$i_N = 50 - 63$		$i_N = 63 - 80$		$i_N = 71 - 90$		$i_N = 90 - 112$		a	b1	c	d2	D2	D3	D4	e4	e5
	d1	l1	d1	l1	d1	l1	d1	l1	d1	l1	d1	l1									
5	40	70			30	50			24	40			690	240	30 ± 1	100	95	100	100	230	252
6			40	70			30	50			24	40	770	240	30 ± 1	110	105	110	110	230	252
7	45	80			35	60			28	50			845	240	36 ± 1	120	115	120	120	280	292
8			45	80			35	60			28	50	950	240	36 ± 1	130	125	130	130	280	312
9	60	125			45	100			32	80			1000	330	45 ± 1.5	140	135	140	140	320	342
10			60	125			45	100			32	80	1100	330	45 ± 1.5	160	150	150	150	320	342
11	70	120			50	80			42	70			1200	330	54 ± 1.5	170	165	165	165	380	402
12			70	120			50	80			42	70	1355	330	54 ± 1.5	180	180	180	180	380	410

机座号 Size	e6	E	f2	f3	G1	G2	G4	G5	G6	h	h1	l2	m1	m2	n1	n2	P1	P2	s	润滑油oil (l)		重量weight (kg)
																				(1)**	(2)**	
5	385	405	28	190	160	165	165	240	165	127.5	205	210	630	360	30	175	35	270	24	35	13	320
6	425	440	28	190	160	165	165	240	165	127.5	205	210	710	360	30	220	35	270	24	37	15	365
7	425	495	30	185	185	195	195	280	195	150	205	210	775	430	35	215	35	330	28	60	25	540
8	485	540	32	185	185	195	195	285	195	150	205	250	880	430	35	275	35	330	28	72	30	625
9	560	580	32	170	230	235	235	330	235	185	275	250	920	490	40	260	40	370	36	100	40	875
10	610	630	32	170	230	235	235	350	235	185	275	300	1020	490	40	310	40	370	36	110	45	1020
11	595	705	35	170	255	270	270	400	270	215	275	300	1100	600	50	295	50	440	40	170	66	1400
12	680	775	35	170	255	270	270	405	270	215	275	300	1255	600	50	380	50	440	40	190	75	1675

(1)**浸油润滑; (2)**强制润滑。

(1)**Dip lubrication, (2)**Forced lubrication.

H3.V13 ~ H3.V22

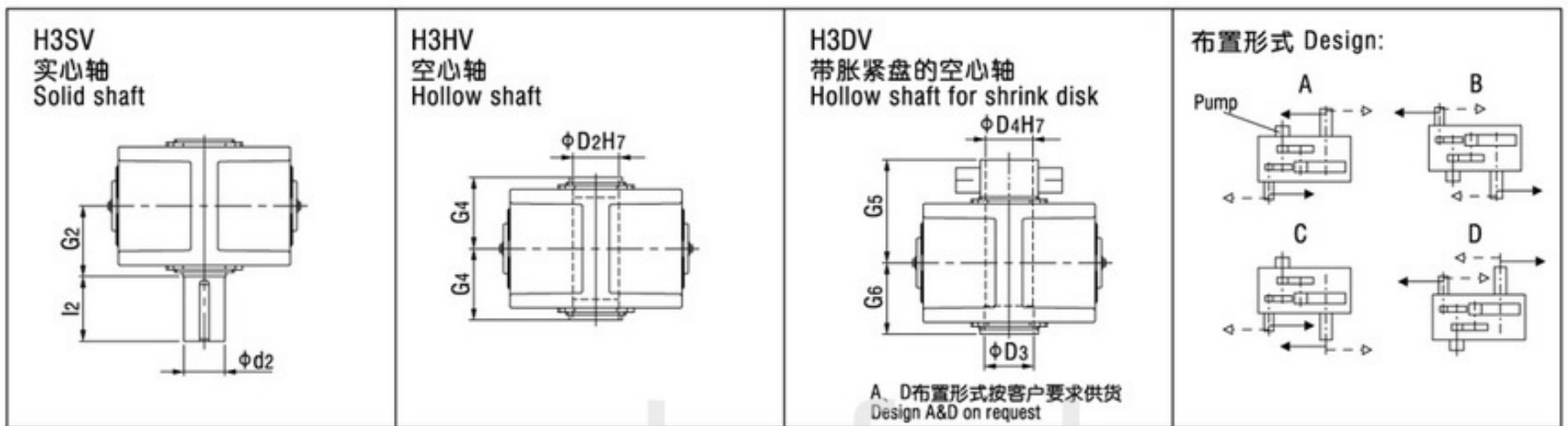
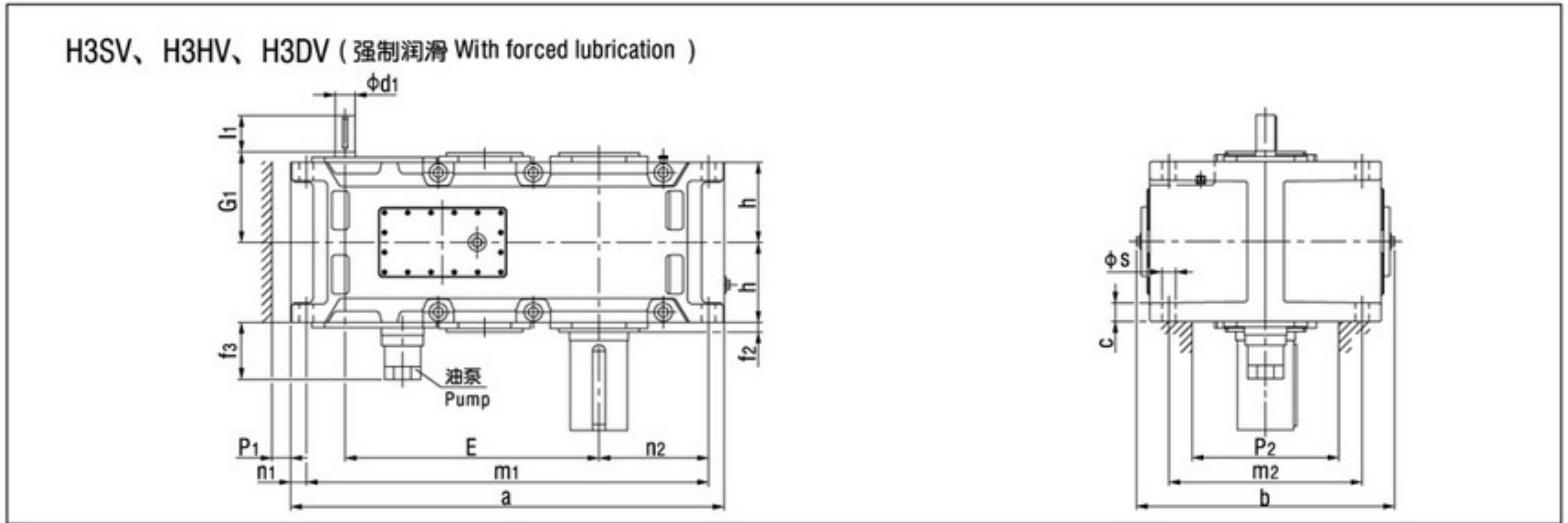

机座号 Size	$i_N=22.4 - 45$		$i_N=25 - 50$		$i_N=28 - 56$		$i_N=50 - 63$		$i_N=56 - 71$		$i_N=63 - 80$		$i_N=71 - 90$		$i_N=80 - 100$		$i_N=90 - 112$		a	b	c	d2	D2
	d1	l1	d1	l1	d1	l1	d1	l1	d1	l1	d1	l1	d1	l1	d1	l1	d1	l1					
13	85	160					60	135					50	110					1395	900	61 ± 2	200	190
14					85	160					60	135					50	110	1535	900	61 ± 2	210	210
15	100	200					75	140					60	140					1680	980	72 ± 2	230	230
16			100	200					75	140					60	140			1770	980	72 ± 2	240	240
17	100	200					75	140					60	140					1770	1110	81 ± 2	250	250
18			100	200					75	140					60	140			1890	1110	81 ± 2	270	275
19	按客户要求供货 On request																						
20																							
21																							
22																							

机座号 Size	D3	D4	E	f2	f3	G1	G2	G4	G5	G6	h	l2	m1	m2	n1	n2	P1	P2	s	润滑油oil (l)	重量weight (kg)
13	190	190	820	35	170	310	335	335	480	335	272.5	350	1300	680	50	360	50	500	48	115	2155
14	210	210	890	35	170	310	335	335	480	335	272.5	350	1440	680	50	430	50	500	48	126	2490
15	230	230	987	42	170	350	380	380	550	380	310	410	1565	750	60	430	50	570	55	180	3260
16	240	240	1033	42	170	350	380	380	550	380	310	410	1655	750	60	475	50	570	55	190	3625
17	250	250	1035	42	210	380	415	415	600	415	340	410	1640	850	70	465	70	630	55	190	4250
18	280	280	1095	42	210	380	415	415	600	415	340	470	1760	850	70	525	70	630	55	200	4740
19	按客户要求供货 On request																				
20																					
21																					
22																					

H4.V7 ~ H4.V12

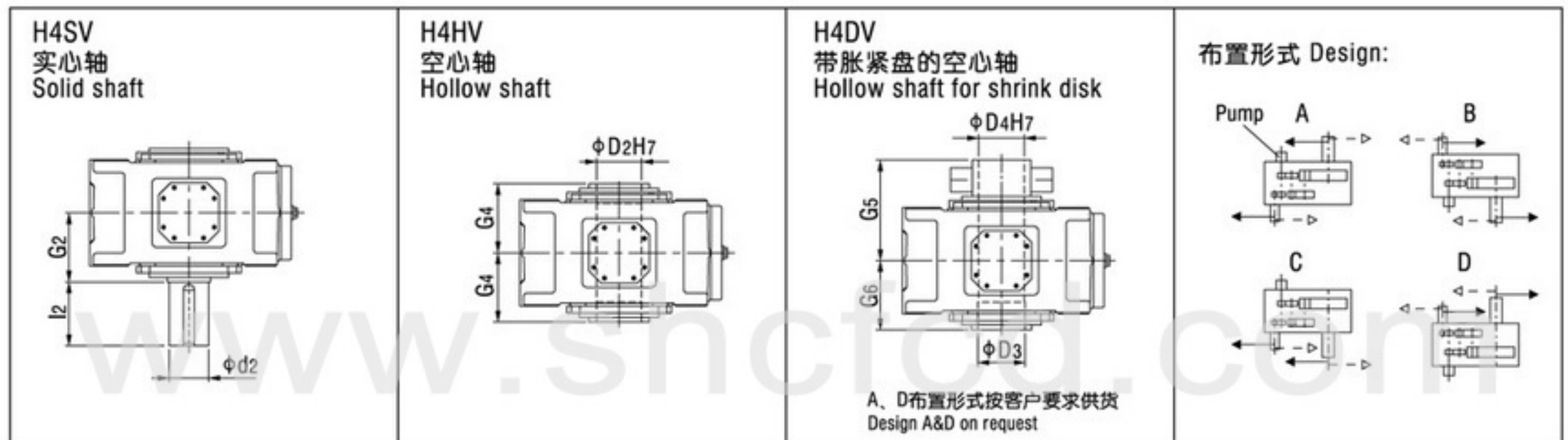
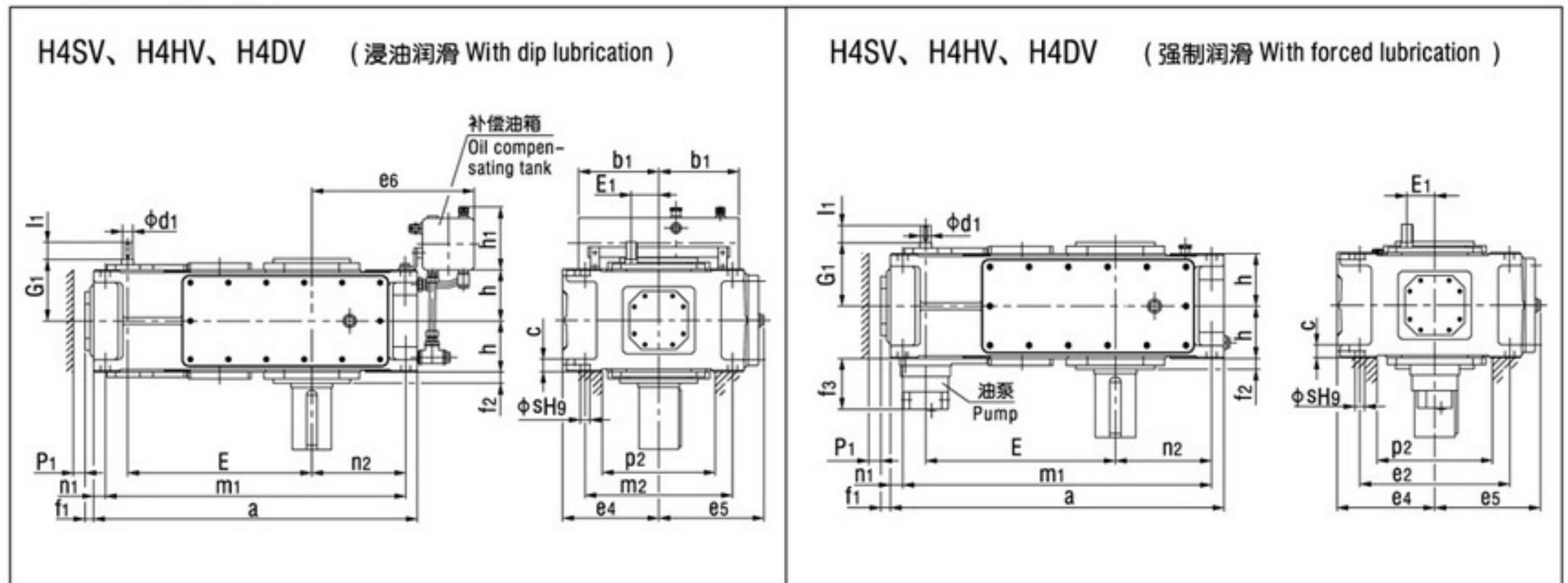

机座号 Size	$i_N = 100 - 180$		$i_N = 125 - 224$		$i_N = 200 - 355$		$i_N = 250 - 450$		a	b1	c	d2	D2	D3	D4	e4	e5	E	
	d1	l1	d1	l1	d1	l1	d1	l1											
7	30	50			24	40			845	240	36 ± 1	120	115	120	120	280	292	425	495
8			30	50			24	40	950	240	36 ± 1	130	125	130	130	280	302	485	540
9	35	60			28	50			1000	330	45 ± 1.5	140	135	140	140	320	342	560	580
10			35	60			28	50	1100	330	45 ± 1.5	160	150	150	150	320	342	610	630
11	45	100			32	80			1200	330	54 ± 1.5	170	165	165	165	380	402	595	705
12			45	100			32	80	1355	330	54 ± 1.5	180	180	180	180	380	410	680	775

机座号 Size	E1	f1	f2	f3	G1	G2	G4	G5	G6	h	h1	l2	m1	m2	n1	n2	P1	P2	s	润滑油oil (l)		重量 weight (kg)
																				(1)**	(2)**	
7	80	37	30	160	180	195	195	280	195	150	205	210	775	430	35	215	35	330	28	50	20	550
8	80	37	32	160	180	195	195	285	195	150	205	250	880	430	35	275	35	330	28	60	25	645
9	90	43	32	170	215	235	235	330	235	185	275	250	920	490	40	260	40	370	36	95	38	875
10	90	43	32	170	215	235	235	350	235	185	275	300	1020	490	40	310	40	370	36	110	45	1010
11	110	47	35	170	250	270	270	400	270	215	275	300	1100	600	50	295	50	440	40	165	65	1460
12	110	47	35	170	250	270	270	405	270	215	275	300	1255	600	50	380	50	440	40	180	75	1725

(1)**浸油润滑; (2)**强制润滑。

(1)**Dip lubrication, (2)**Forced lubrication.

H4.V13 ~ H4.V22

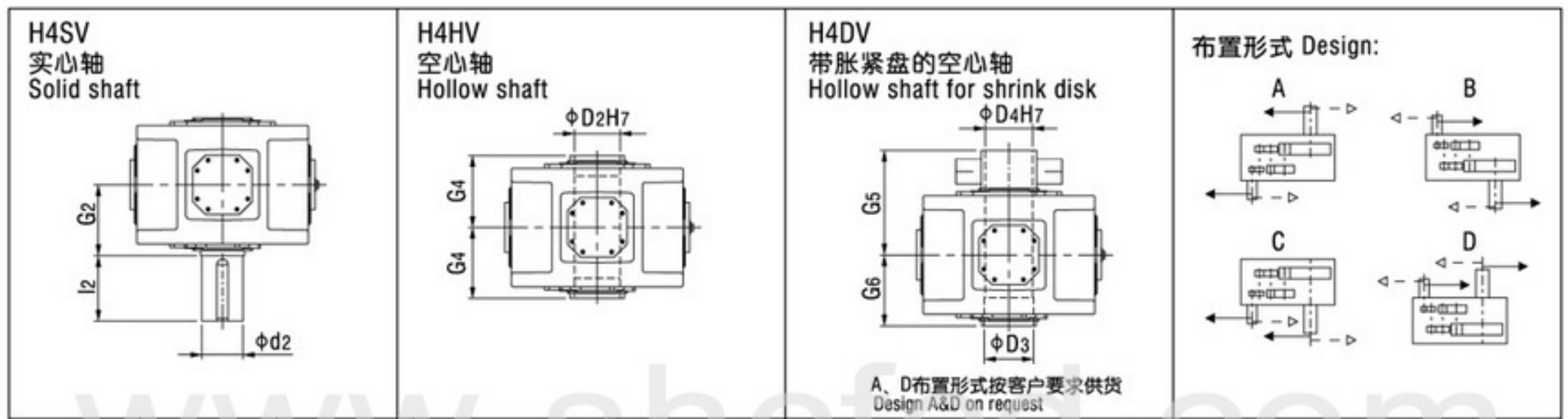
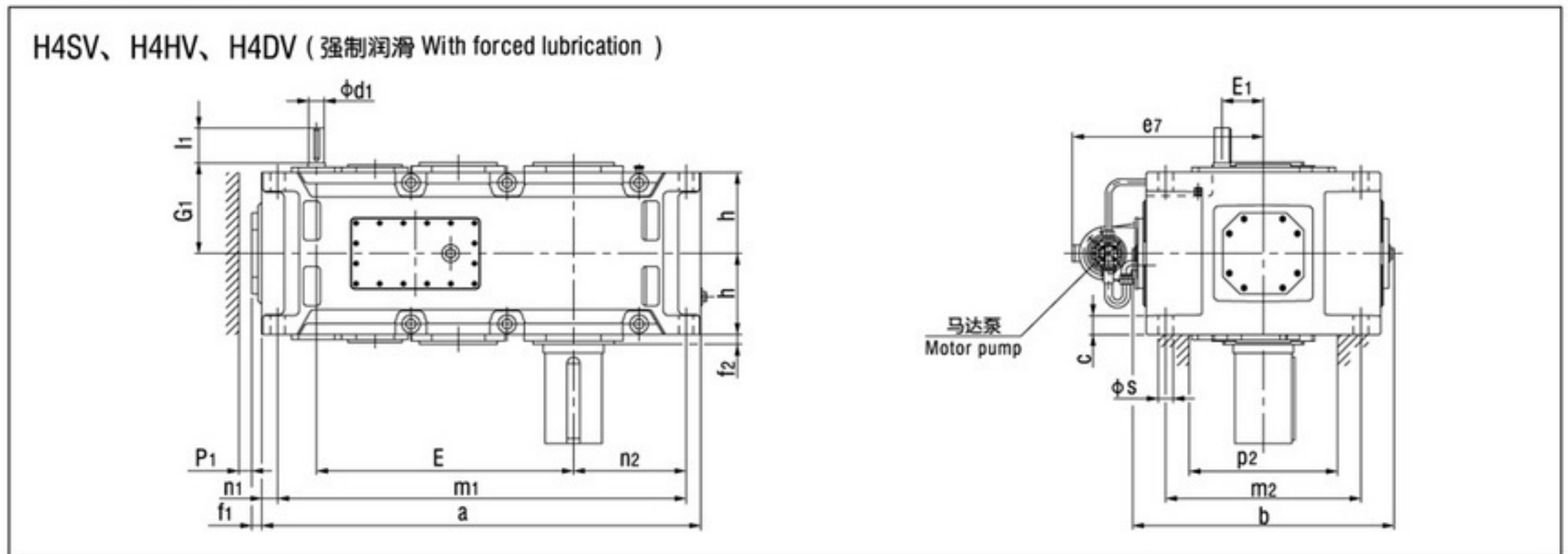

机座号 Size	$i_N = 100 - 180$		$i_N = 112 - 200$		$i_N = 125 - 224$		$i_N = 200 - 355$		$i_N = 224 - 400$		$i_N = 250 - 450$		a	b	c	d2	D2	D3	D4	e7
	d1	l1	d1	l1	d1	l1	d1	l1	d1	l1	d1	l1								
13	50	100					38	80					1395	900	61±2	200	190	190	190	670
14					50	100					38	80	1535	900	61±2	210	210	210	210	670
15	60	135					50	110					1680	980	72±2	230	230	230	230	710
16			60	135					50	110			1770	980	72±2	240	240	240	240	710
17	60	105					50	80					1770	1110	81±2	250	250	250	250	775
18			60	105					50	80			1890	1110	81±2	270	275	280	280	775
19	按客户要求供货 On request																			
20																				
21																				
22																				

机座号 Size	E	E1	f1	f2	G1	G2	G4	G5	G6	h	l2	m1	m2	n1	n2	p1	p2	s	润滑油oil (l)	重量weight (kg)
13	820	130	47	35	305	335	335	480	335	272.5	350	1300	680	50	360	50	500	48	95	2270
14	890	130	47	35	305	335	335	480	335	272.5	350	1440	680	50	430	50	500	48	105	2600
15	987	160	56	42	345	380	380	550	380	310	410	1565	750	60	430	50	570	55	150	3440
16	1033	160	56	42	345	380	380	550	380	310	410	1655	750	60	475	50	570	55	160	3740
17	1035	160	53	42	380	415	415	600	415	340	410	1640	850	70	465	70	630	55	190	4445
18	1095	160	53	42	380	415	415	600	415	340	470	1760	850	70	525	70	630	55	200	4915
19	按客户要求供货 On request																			
20																				
21																				
22																				

B2.V4 ~ B2.V12

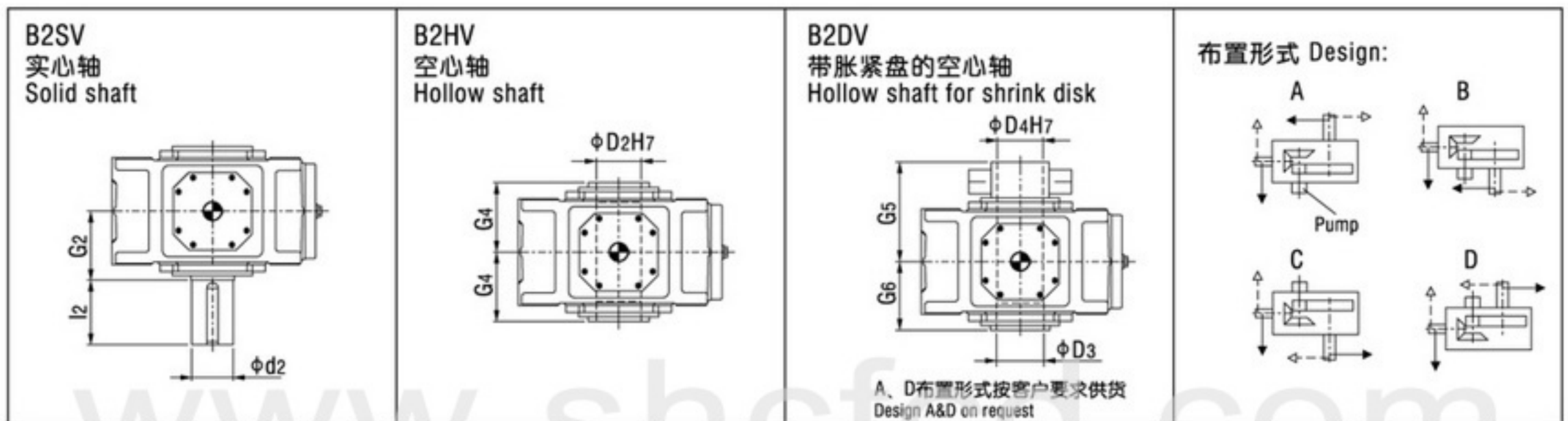
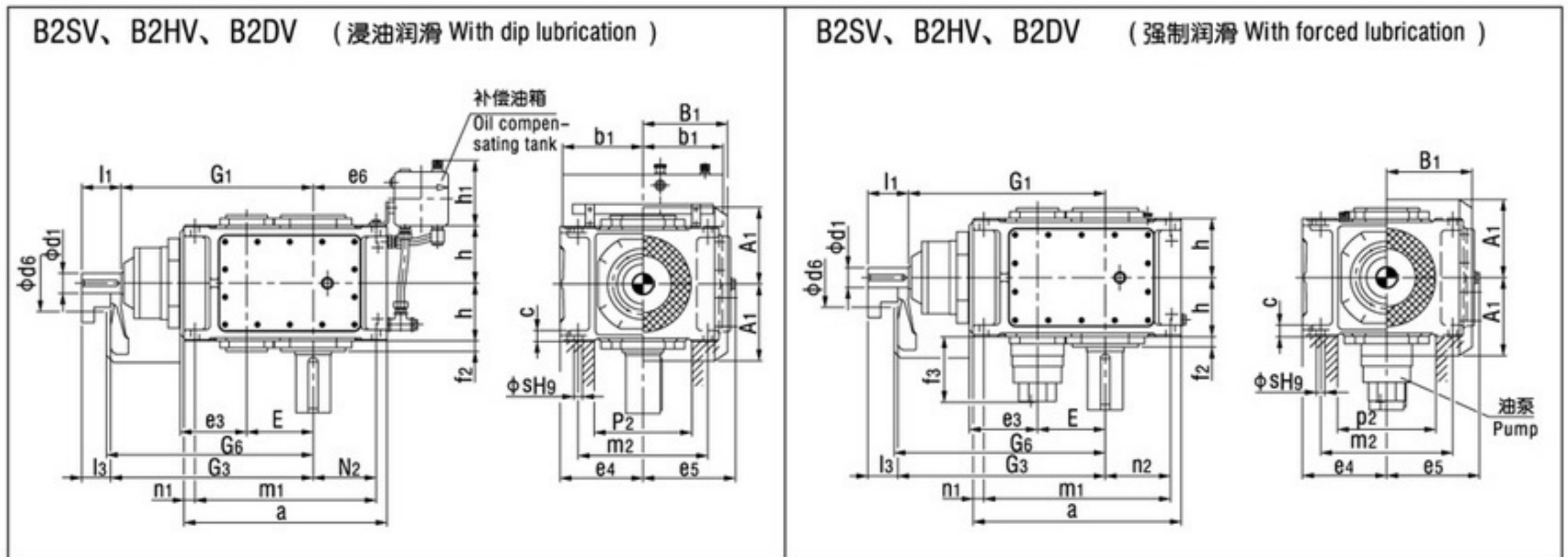

机座号 Size	i _N = 5 - 11.2			i _N = 6.3 - 14			a	A ₁	b ₁	B ₁	c	d ₂	d ₆	D ₂	D ₃	D ₄	e ₃	e ₄	e ₅
	d ₁	l ₁	l ₃	d ₁	l ₁	l ₃													
4	50	100	80				505	188	150	200	30±1	80	150	80	85	85	160	200	215
5	60	110	80				565	215	240	235	30±1	100	160	95	100	100	185	230	252
6				60	110	80	645	215	240	235	30±1	110	160	105	110	110	185	230	252
7	75	135	105				690	250	240	285	36±1	120	210	115	120	120	225	280	302
8				75	135	105	795	250	240	285	36±1	130	210	125	130	130	225	280	302
9	85	165	130				820	270	330	325	48±1.5	140	195	135	140	140	265	320	342
10				85	165	130	920	270	330	325	48±1.5	160	195	150	150	150	265	320	342
11	95	165	130				975	328	330	385	54±1.5	170	210	165	165	165	320	380	410
12				95	165	130	1130	328	330	385	54±1.5	180	210	180	180	180	320	380	410

机座号 Size	e ₆	E	f ₂	f ₃	G ₁	G ₂	G ₃	G ₄	G ₅	G ₆	G ₇	h	h ₁	l ₂	m ₁	m ₂	n ₁	n ₂	p ₂	s	润滑油oil (l)		重量 weight (kg)
																					(1)**	(2)**	
4	320	160	26	-	465	170	485	170	235	170	495	135	165	170	445	300	30	160	220	24	28	-	235
5	385	185	30	190	535	200	565	200	275	200	575	160	205	210	505	360	30	175	270	24	41	20	360
6	425	220	30	190	570	200	600	200	275	200	610	160	205	210	585	360	30	220	270	24	50	23	410
7	425	225	32	200	640	235	670	235	320	235	685	190	205	210	620	430	35	215	330	28	75	35	615
8	485	270	32	200	685	235	715	235	325	235	730	190	205	250	725	430	35	275	330	28	90	38	700
9	560	265	45	200	755	270	790	270	365	270	805	220	275	250	740	490	40	260	370	36	115	53	1000
10	610	315	45	200	805	270	840	270	385	270	855	220	275	300	840	490	40	310	370	36	135	60	1155
11	595	320	47	200	925	320	960	320	450	320	980	265	275	300	875	600	50	295	440	40	190	86	1640
12	680	390	47	200	995	320	1030	320	455	320	1050	265	275	300	1030	600	50	380	440	40	215	95	1910

(1)**浸油润滑; (2)**强制润滑。

(1)**Dip lubrication, (2)**Forced lubrication.

B2.V13 ~ B2.V18

B2SV、B2HV、B2DV (强制润滑 With forced lubrication)

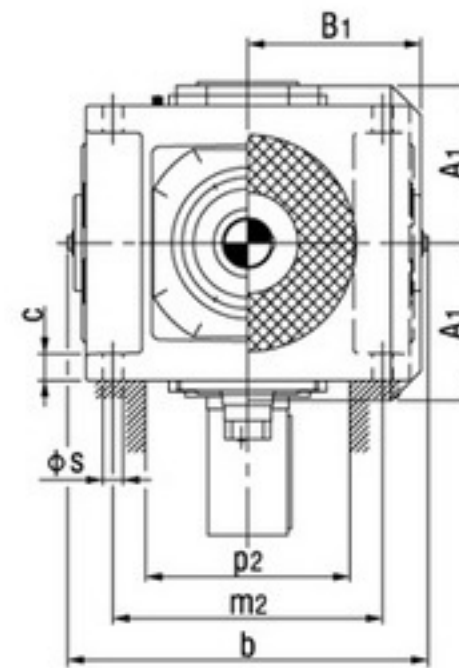
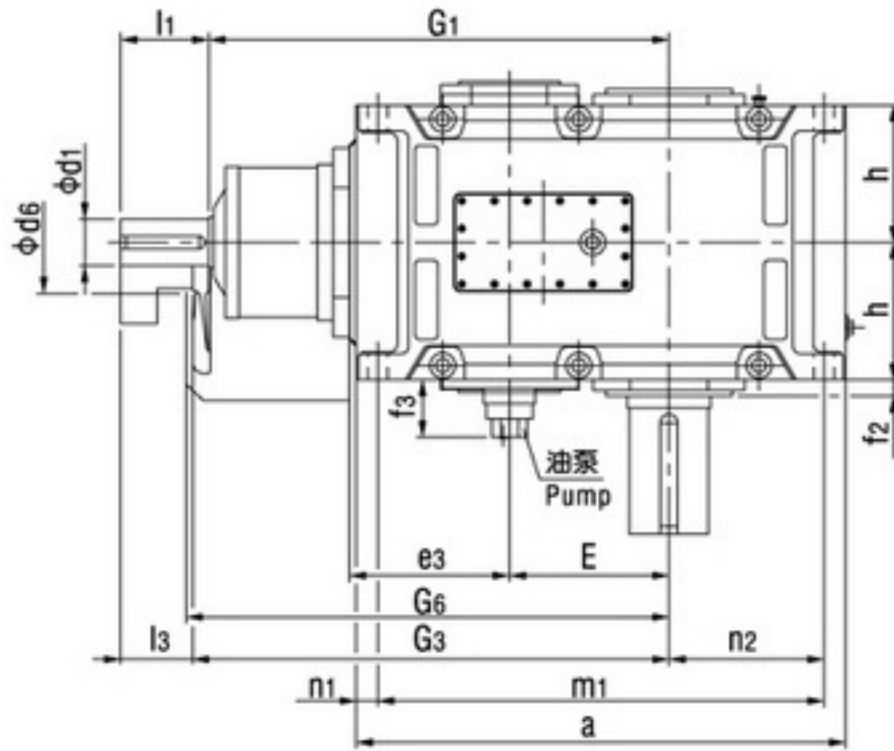

B2SV
实心轴
Solid shaft

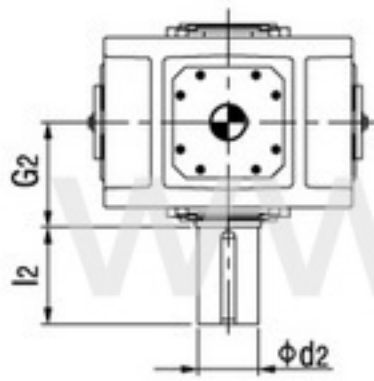

B2HV
空心轴
Hollow shaft

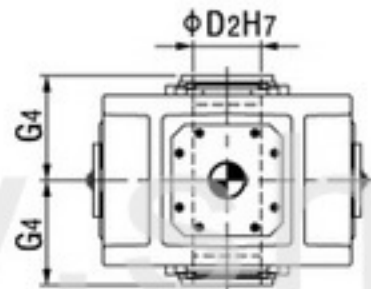

B2DV
带胀紧盘的空心轴
Hollow shaft for shrink disk

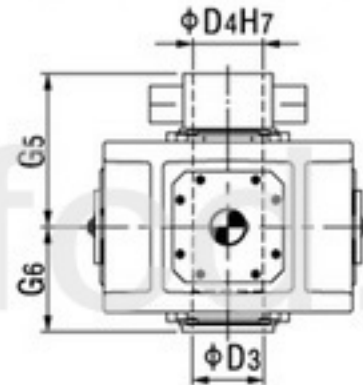

A、D布置形式按客户要求供货
Design A&D on request

布置形式 Design:

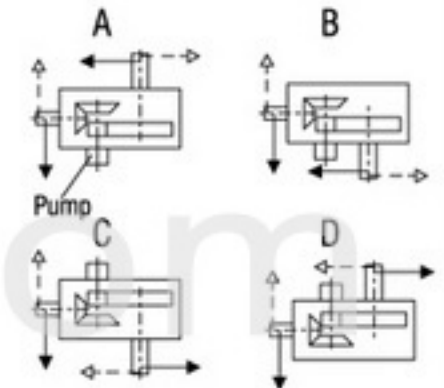

机座号 Size	$i_N = 5 - 11.2$			$i_N = 5.6 - 11.2$			$i_N = 5.6 - 12.5$			$i_N = 6.3 - 14$			$i_N = 7.1 - 12.5$			a	A1	b	B1	c	d2	d6	D2	D3	
	d1	l1	l3	d1	l1	l3	d1	l1	l3	d1	l1	l3	d1	l1	l3										
13	115	205	165													1130	375	900	450	61±2	200	245	-	-	
14									115	205	165					1270	375	900	450	61±2	210	245	210	210	
15	140	245	200													1350	435	980	495	72±2	230	280	-	-	
16							140	245	200							1440	435	980	495	72±2	240	280	240	240	
17				150	245	200										1490	505	1110	555	81±2	250	380	-	-	
18														150	245	200	1610	505	1110	555	81±2	270	380	275	280

机座号 Size	D4	e3	E	f2	f3	G1	G2	G3	G4	G5	G6	G7	h	l2	m1	m2	n1	n2	p2	s	润滑油oil (l)	重量weight (kg)
13	-	380	370	38	200	1070	390	1110	-	-	-	1130	325	350	1035	680	50	360	500	48	100	2350
14	210	380	440	45	200	1140	390	1180	390	535	390	1200	325	350	1175	680	50	430	500	48	110	2725
15	-	450	442	75	200	1277	460	1322	-	-	-	1340	380	410	1235	750	60	430	570	55	145	3795
16	240	450	488	75	200	1323	460	1368	450	620	450	1385	380	410	1325	750	60	475	570	55	160	4160
17	-	510	490	98	200	1435	540	1480	-	-	-	1500	437.5	410	1360	840	70	465	630	65	210	5320
18	280	510	550	98	200	1495	540	1540	510	700	510	1560	437.5	470	1480	840	70	525	630	65	220	5860

B3.V4 ~ B3.V12

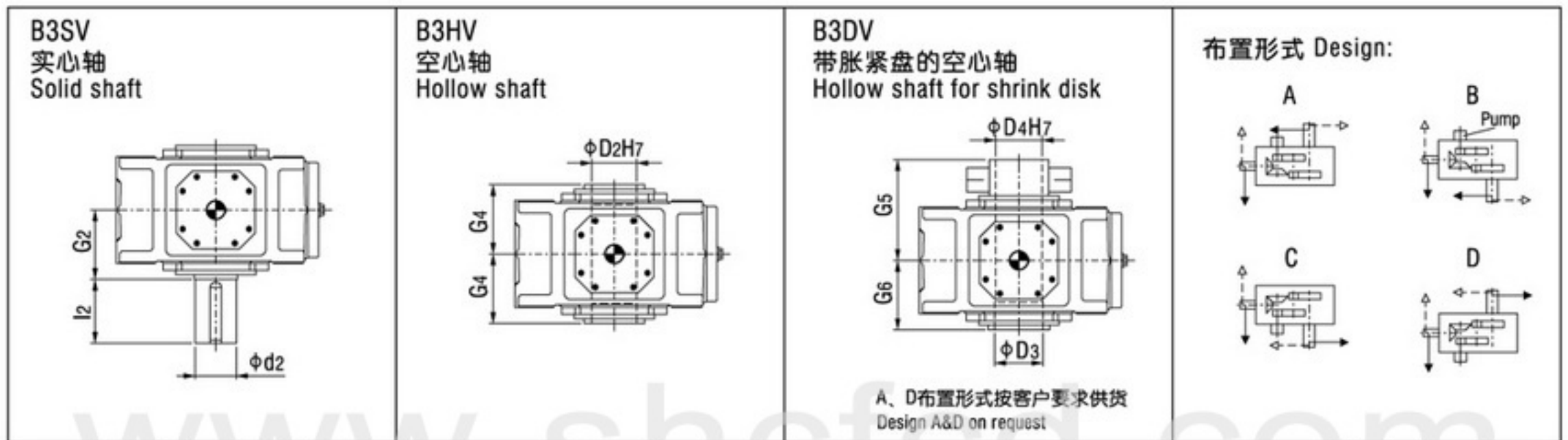
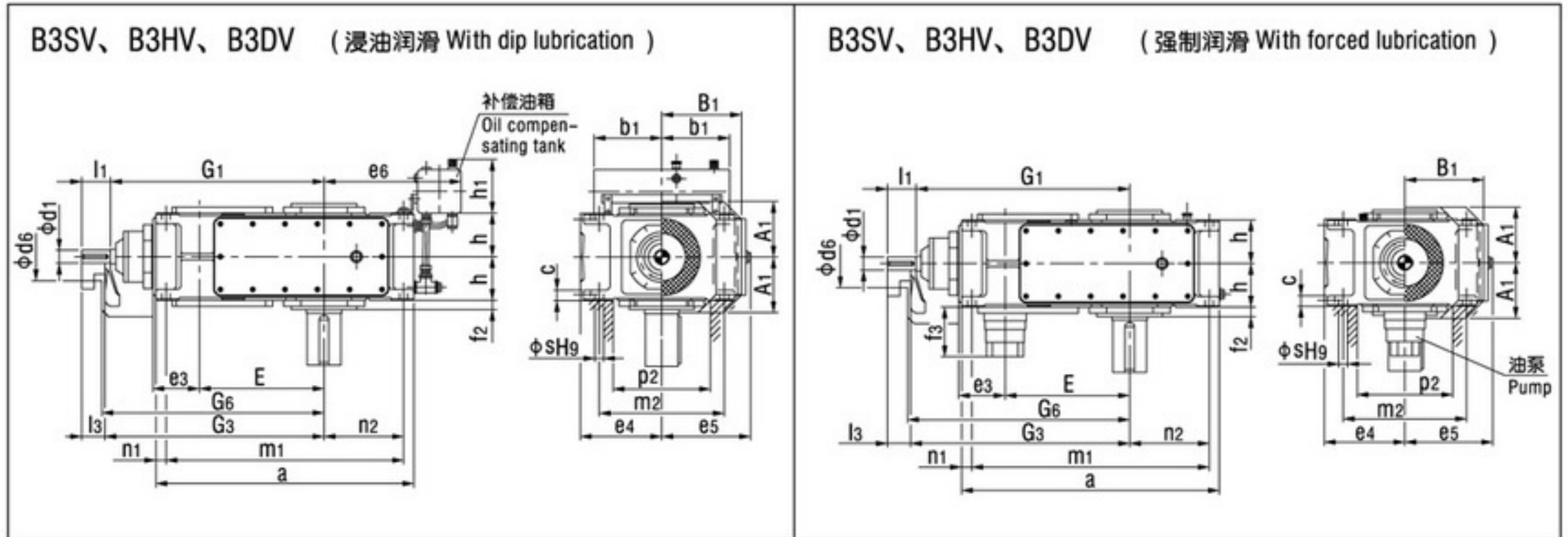

机座号 Size	$i_N = 12.5 - 45$			$i_N = 16 - 56$			$i_N = 50 - 71$			$i_N = 63 - 90$			a	A1	b1	B1	c	d2	d6	D2	D3	D4	e3	e4
	d1	l1	l3	d1	l1	l3	d1	l1	l3	d1	l1	l3												
4	35	70	50				30	60	40				565	143	150	200	30 ± 1	80	110	80	85	85	110	200
5	45	80	60				35	60	40				640	168	240	235	30 ± 1	100	130	95	100	100	130	230
6				45	80	60				35	60	40	720	168	240	235	30 ± 1	110	130	105	110	110	130	230
7	50	100	80				40	80	60				785	193	240	275	36 ± 1	120	165	115	120	120	160	280
8				50	100	80				40	80	60	890	193	240	275	36 ± 1	130	165	125	130	130	160	280
9	60	110	80				50	100	70				925	231	330	325	45 ± 1.5	140	175	135	140	140	185	320
10				60	110	80				50	100	70	1025	231	330	325	45 ± 1.5	160	175	150	150	150	185	320
11	75	135	105				60	110	80				1105	263	330	385	54 ± 1.5	170	190	165	165	165	225	380
12				75	135	105				60	110	80	1260	263	330	385	54 ± 1.5	180	190	180	180	180	225	380

机座号 Size	e5	e6	E	f2	f3	G1	G2	G3	G4	G5	G6	G7	h	h1	l2	m1	m2	n1	n2	p2	s	润滑油oil (l)		重量 weight (kg)
																						(1)**	(2)**	
4	215	320	270	22	-	500	140	520	140	205	140	530	107.5	165	170	505	300	30	160	220	24	28	-	210
5	252	385	315	28	190	575	165	595	165	240	165	605	127.5	205	210	580	360	30	175	270	24	32	12	325
6	252	425	350	28	190	610	165	630	165	240	165	640	127.5	205	210	660	360	30	220	270	24	35	13	380
7	292	425	385	30	190	690	195	710	195	280	195	720	150	205	210	715	430	35	215	330	28	52	22	550
8	302	485	430	32	190	735	195	755	195	285	195	765	150	205	250	820	430	35	275	330	28	67	28	635
9	342	560	450	32	180	800	235	830	235	330	235	845	185	275	250	845	490	40	260	370	36	115	48	890
10	342	610	500	32	180	850	235	880	235	350	235	895	185	275	300	945	490	40	310	370	36	125	52	1020
11	402	595	545	35	180	960	270	990	270	400	270	1010	215	275	300	1005	600	50	295	440	40	180	75	1455
12	410	680	615	35	180	1030	270	1060	270	405	270	1080	215	275	300	1160	600	50	380	440	40	200	85	1730

(1)**浸油润滑; (2)**强制润滑。

(1)**Dip lubrication, (2)**Forced lubrication.

B3.V13 ~ B3.V18

B3SV、B3HV、B3DV (强制润滑 With forced lubrication)

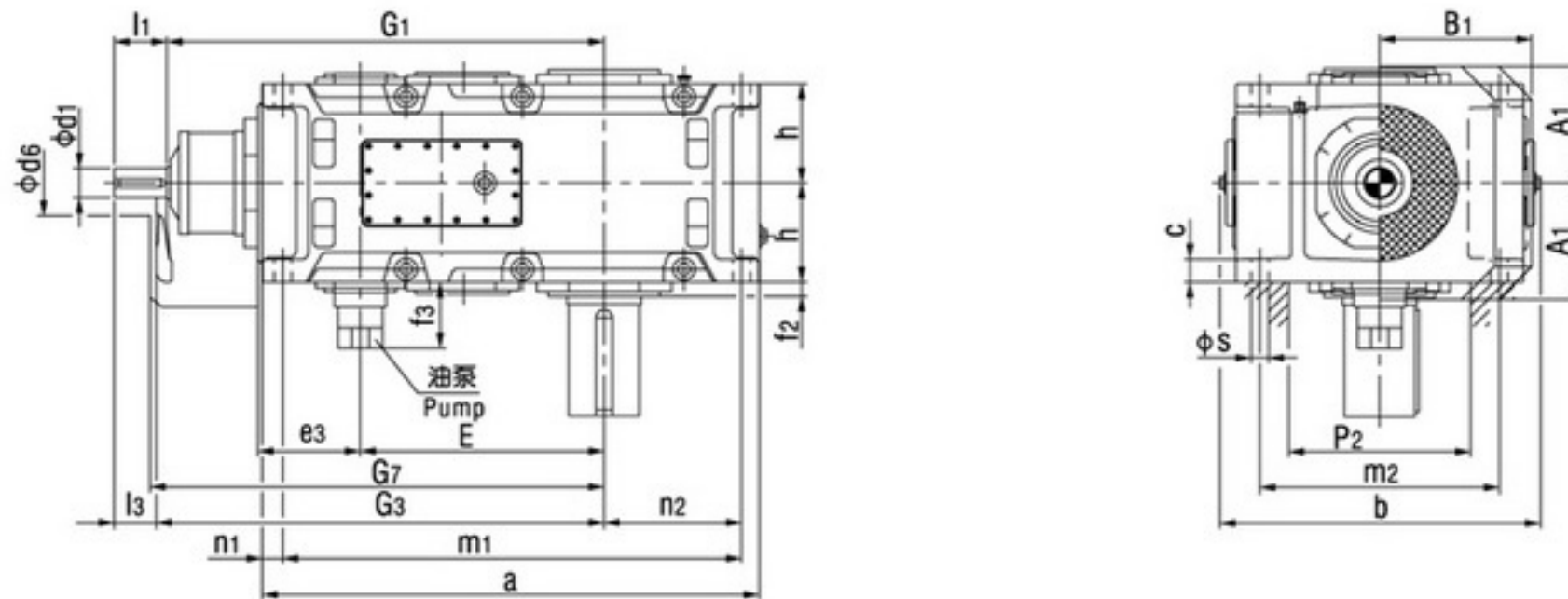

B3SV
实心轴
Solid shaft

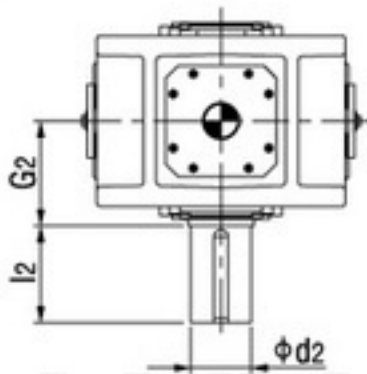

B3HV
空心轴
Hollow shaft

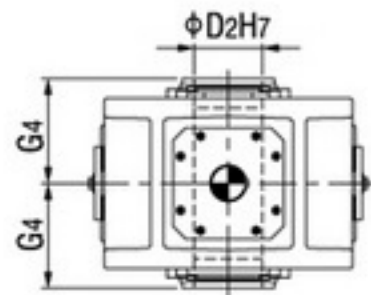

B3DV
带胀紧盘的空心轴
Hollow shaft for shrink disk

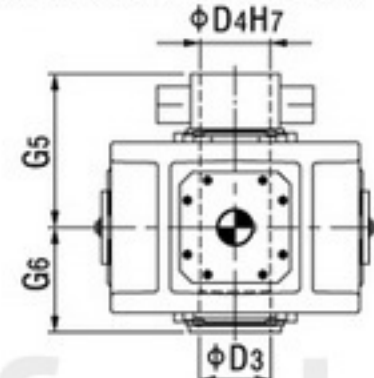

A、D布置形式按客户要求供货
Design A&D on request

布置形式 Design:

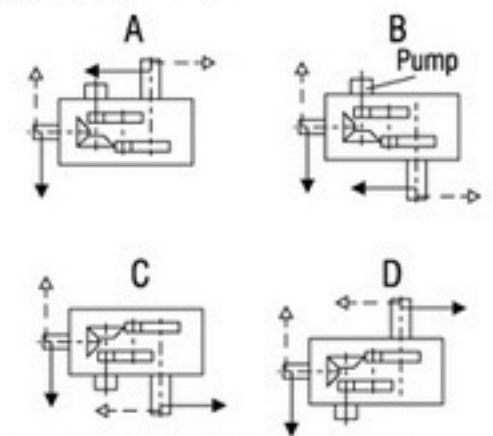

机座号 Size	i _N = 12.5 - 45			i _N = 14 - 50			i _N = 16 - 56			i _N = 50 - 71			i _N = 56 - 80			i _N = 63 - 90			a	A1	b	B1	c	d2	d6	D2
	d1	l1	l3	d1	l1	l3	d1	l1	l3	d1	l1	l3	d1	l1	l3	d1	l1	l3								
13	85	165	130							70	140	105							1290	325	900	475	61±2	200	210	190
14							85	165	130							70	140	105	1430	325	900	475	61±2	210	210	210
15	95	165	130							75	140	105							1550	365	980	520	72±2	230	210	230
16				95	165	130							75	140	105				1640	365	980	520	72±2	240	210	240
17	115	205	165							90	170	130							1740	395	1110	570	81±2	250	230	250
18				115	205	165							90	170	130				1860	395	1110	570	81±2	270	230	275
19	按客户要求供货 On request																									
20																										
21																										
22																										

机座号 Size	D3	D4	e3	E	f2	f3	G1	G2	G3	G4	G5	G6	G7	h	l2	m1	m2	n1	n2	p2	s	润滑油oil (l)	重量weight (kg)
13	190	190	265	635	35	170	1125	335	1160	335	480	335	1180	272.5	350	1195	680	50	360	500	48	95	2260
14	210	210	265	705	35	170	1195	335	1230	335	480	335	1250	272.5	350	1335	680	50	430	500	48	110	2615
15	230	230	320	762	42	170	1367	380	1402	380	550	380	1420	310	410	1435	750	60	430	570	55	165	3540
16	240	240	320	808	42	170	1413	380	1448	380	550	380	1470	310	410	1525	750	60	475	570	55	190	3765
17	250	250	370	860	42	170	1560	415	1600	415	600	415	1620	340	410	1610	850	70	465	630	55	210	4760
18	280	280	370	920	42	170	1620	415	1660	415	600	415	1680	340	470	1730	850	70	525	630	55	240	5240
19	按客户要求供货 On request																						
20																							
21																							
22																							

B4.V5 ~ B4.V12

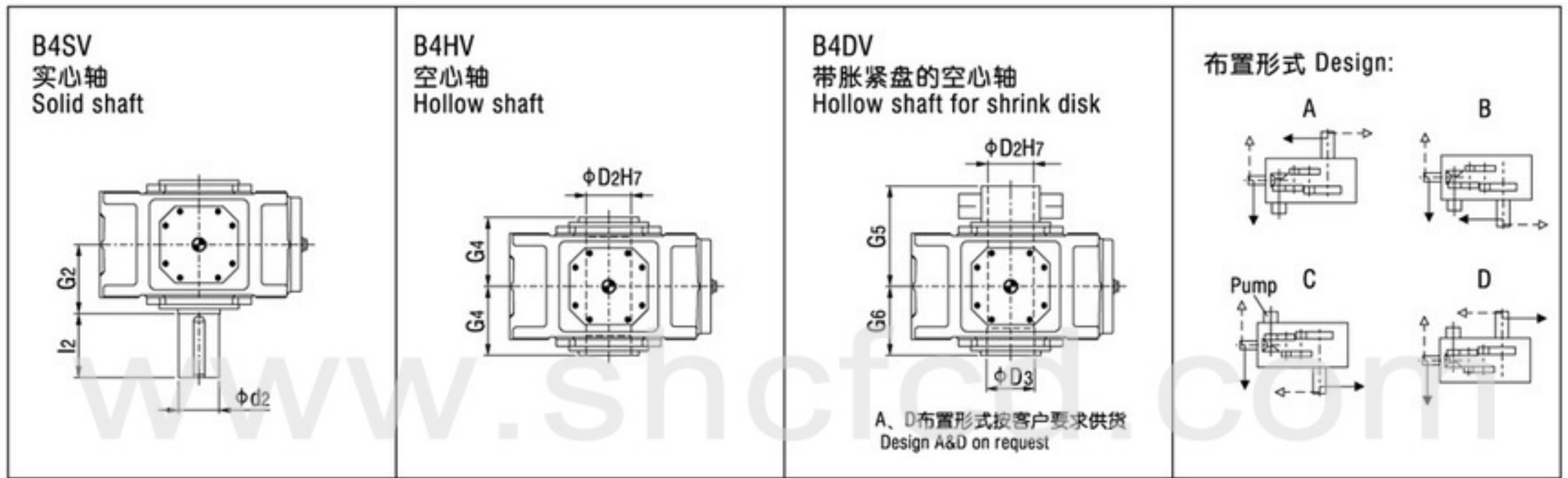
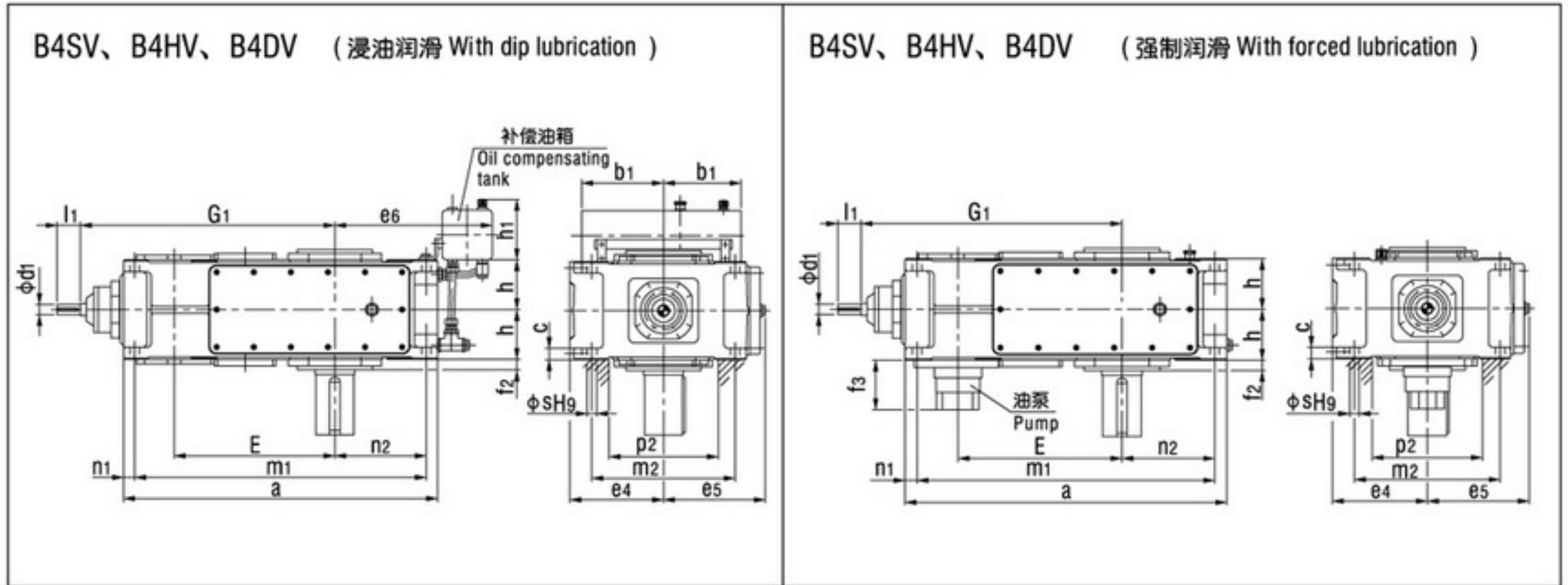

机座号 Size	$i_N = 80 - 180$		$i_N = 100 - 224$		$i_N = 200 - 315$		$i_N = 250 - 400$		a	b1	c	d2	D2	D3	D4	e4	e5	e6
	d1	l1	d1	l1	d1	l1	d1	l1										
5	35	55			25	50			690	240	30±1	100	95	100	100	230	252	385
6			35	55			25	50	770	240	30±1	110	105	110	110	230	252	425
7	35	70			30	60			845	240	36±1	120	115	120	120	280	292	425
8			35	70			30	60	950	240	36±1	130	125	130	130	280	302	485
9	45	80			35	60			1000	330	45±1.5	140	135	140	140	320	342	560
10			45	80			35	60	1100	330	45±1.5	160	150	150	150	320	342	610
11	50	100			40	80			1200	330	54±1.5	170	165	165	165	380	402	595
12			50	100			40	80	1355	330	54±1.5	180	180	180	180	380	410	680

机座号 Size	E	G1	f2	f3	G2	G4	G5	G6	h	h1	l2	m1	m2	n1	n2	p2	s	润滑油oil (l)		重量 weight (kg)
																		(1)**	(2)**	
5	405	615	28	200	165	165	240	165	127.5	205	210	630	360	30	175	270	24	36	15	335
6	440	650	28	200	165	165	240	165	127.5	205	210	710	360	30	220	270	24	40	16	385
7	495	725	30	120	195	195	280	195	150	205	210	775	430	35	215	330	28	60	30	555
8	540	770	32	120	195	195	285	195	150	205	250	880	430	35	275	330	28	70	35	655
9	580	840	32	120	235	235	330	235	185	275	250	920	490	40	260	370	36	110	60	890
10	630	890	32	120	235	235	350	235	185	275	300	1020	490	40	310	370	36	130	67	1025
11	705	1010	35	130	270	270	440	270	215	275	300	1100	600	50	295	440	40	180	75	1485
12	775	1080	35	130	270	270	405	270	215	275	300	1255	600	50	380	440	40	195	85	1750

(1)**浸油润滑; (2)**强制润滑。

(1)**Dip lubrication, (2)**Forced lubrication.

B4.V13 ~ B4.V22

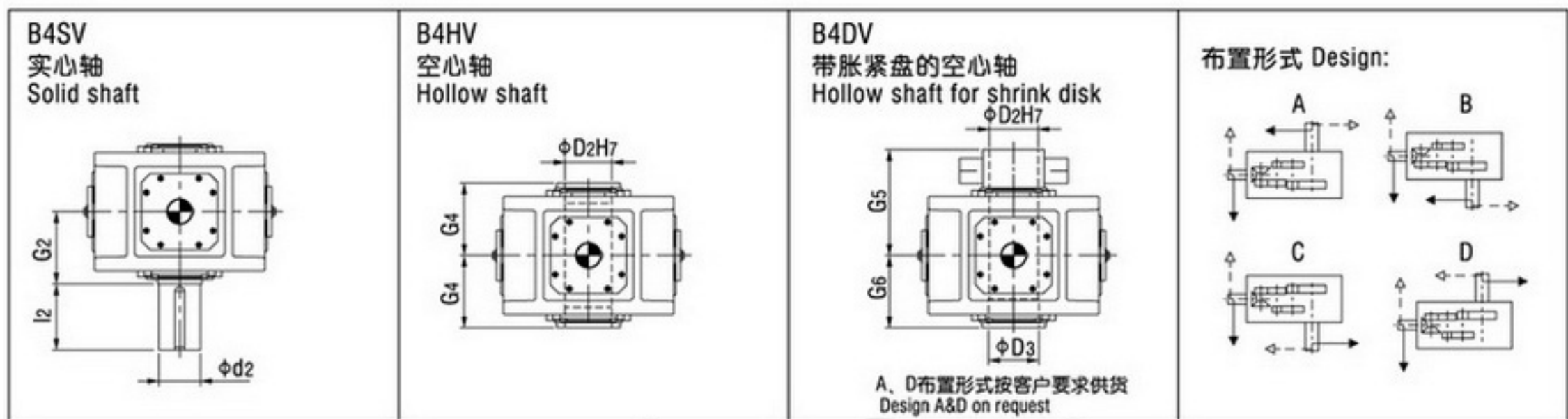
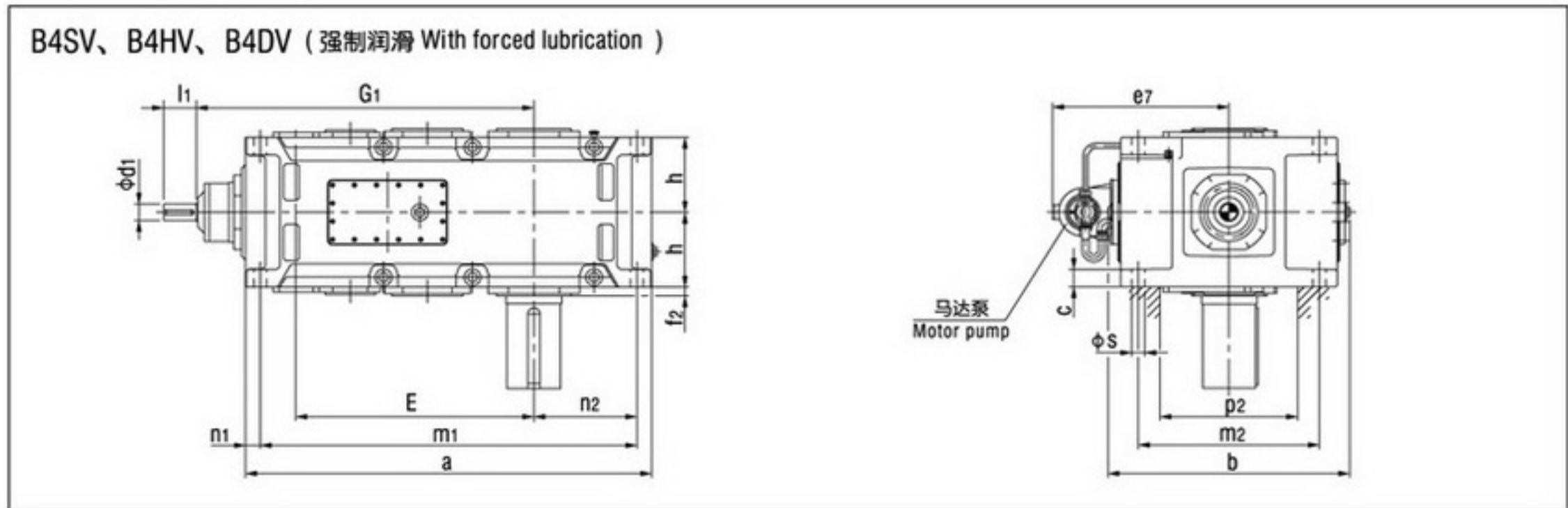

机座号 Size	$i_N = 80 - 180$		$i_N = 90 - 200$		$i_N = 100 - 224$		$i_N = 200 - 315$		$i_N = 224 - 355$		$i_N = 250 - 400$		a	b	c	d2	D2	D3
	d1	l1	d1	l1	d1	l1	d1	l1	d1	l1	d1	l1						
13	60	110					50	100					1395	900	61 ± 2	200	190	190
14					60	110					50	100	1535	900	61 ± 2	210	210	210
15	75	135					60	110					1680	980	72 ± 2	230	230	230
16			75	135					60	110			1770	980	72 ± 2	240	240	240
17	75	135					60	110					1770	1110	81 ± 2	250	250	250
18			75	135					60	110			1890	1110	81 ± 2	270	275	280
19	按客户要求供货 On request																	
20																		
21																		
22																		

机座号 Size	D4	e7	E	f2	G1	G2	G4	G5	G6	h	l2	m1	m2	n1	n2	p2	s	润滑油oil (l)	重量weight (kg)
13	190	670	820	35	1170	335	335	480	335	272.5	350	1300	680	50	360	500	48	130	2280
14	210	670	890	35	1240	335	335	480	335	272.5	350	1440	680	50	430	500	48	150	2605
15	230	710	987	42	1402	380	380	550	380	310	410	1565	750	60	430	570	55	200	3435
16	240	710	1033	42	1448	380	380	550	380	310	410	1655	750	60	475	570	55	235	3765
17	250	775	1035	42	1450	415	415	600	415	340	410	1640	850	70	465	630	55	215	4460
18	280	775	1095	42	1510	415	415	600	415	340	470	1760	850	70	525	630	55	250	4930
19	按客户要求供货 On request																		
20																			
21																			
22																			

HB系列轴布置形式:

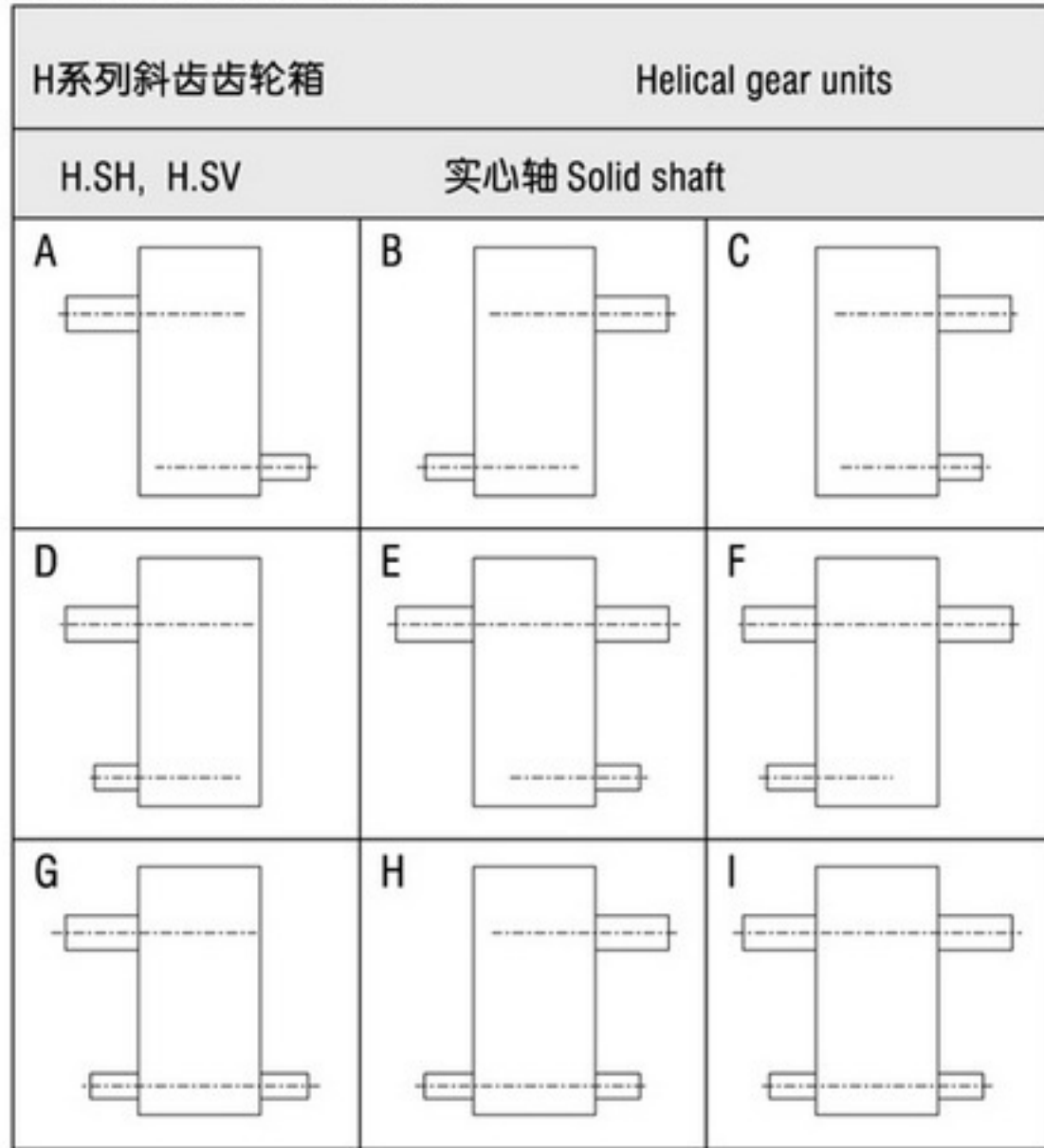

Design:

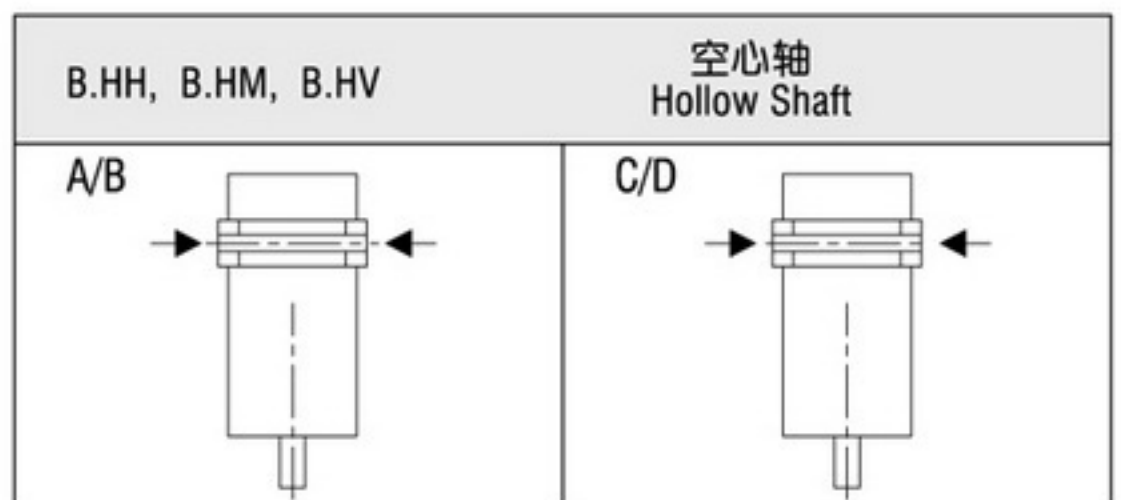
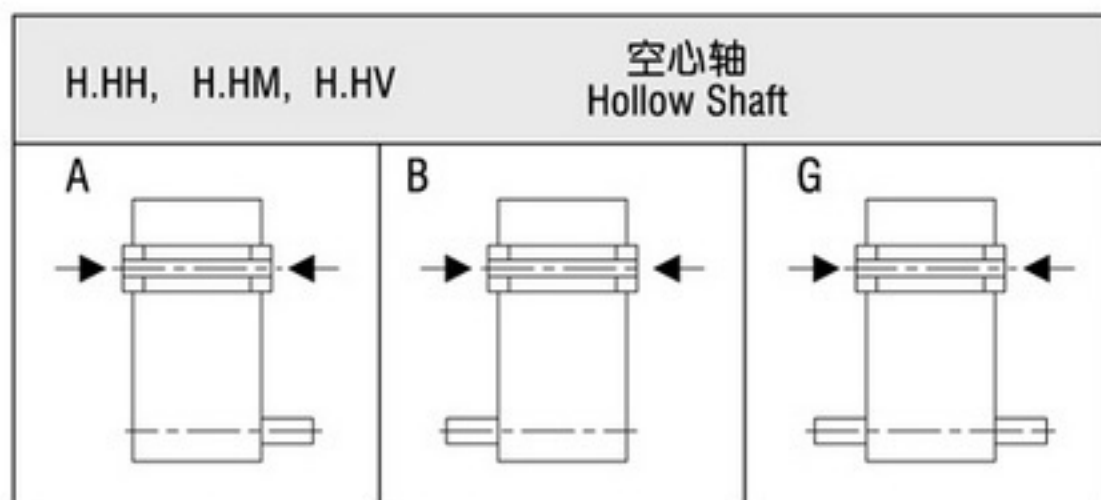
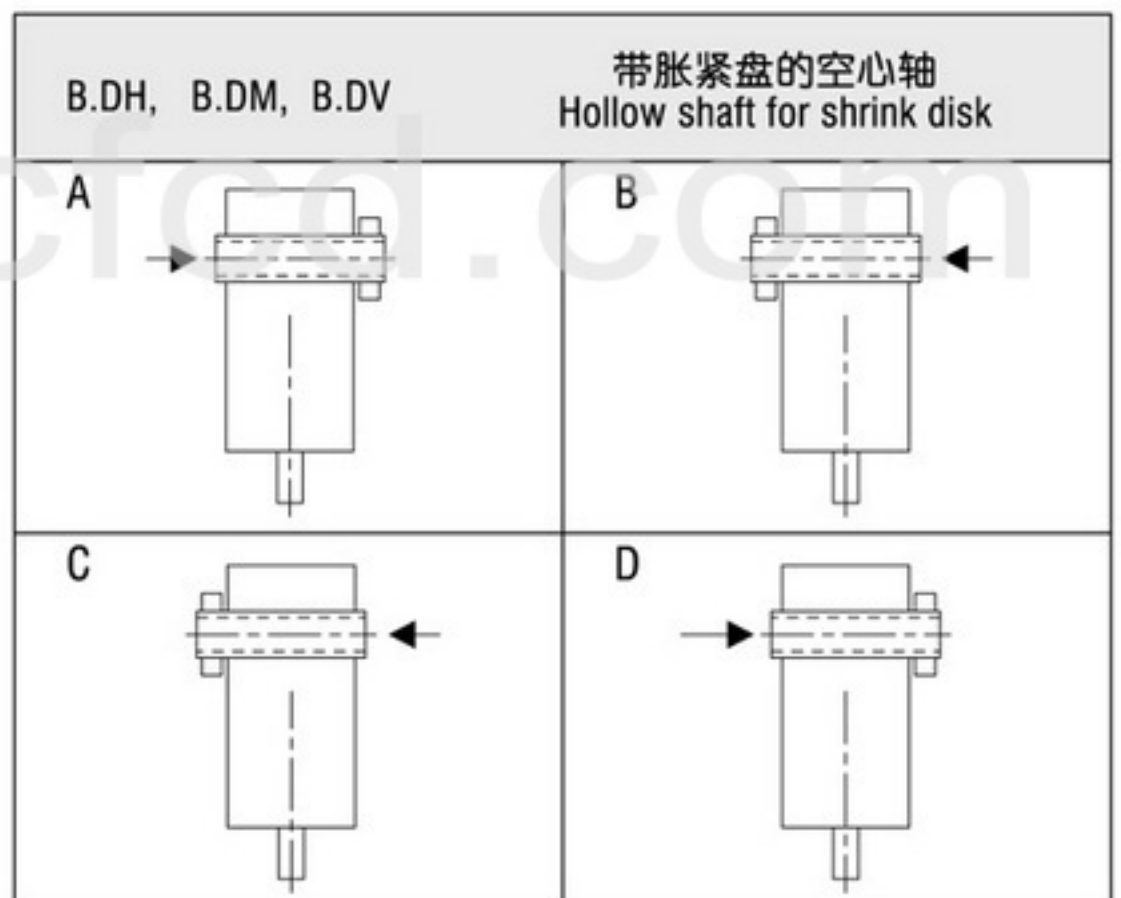
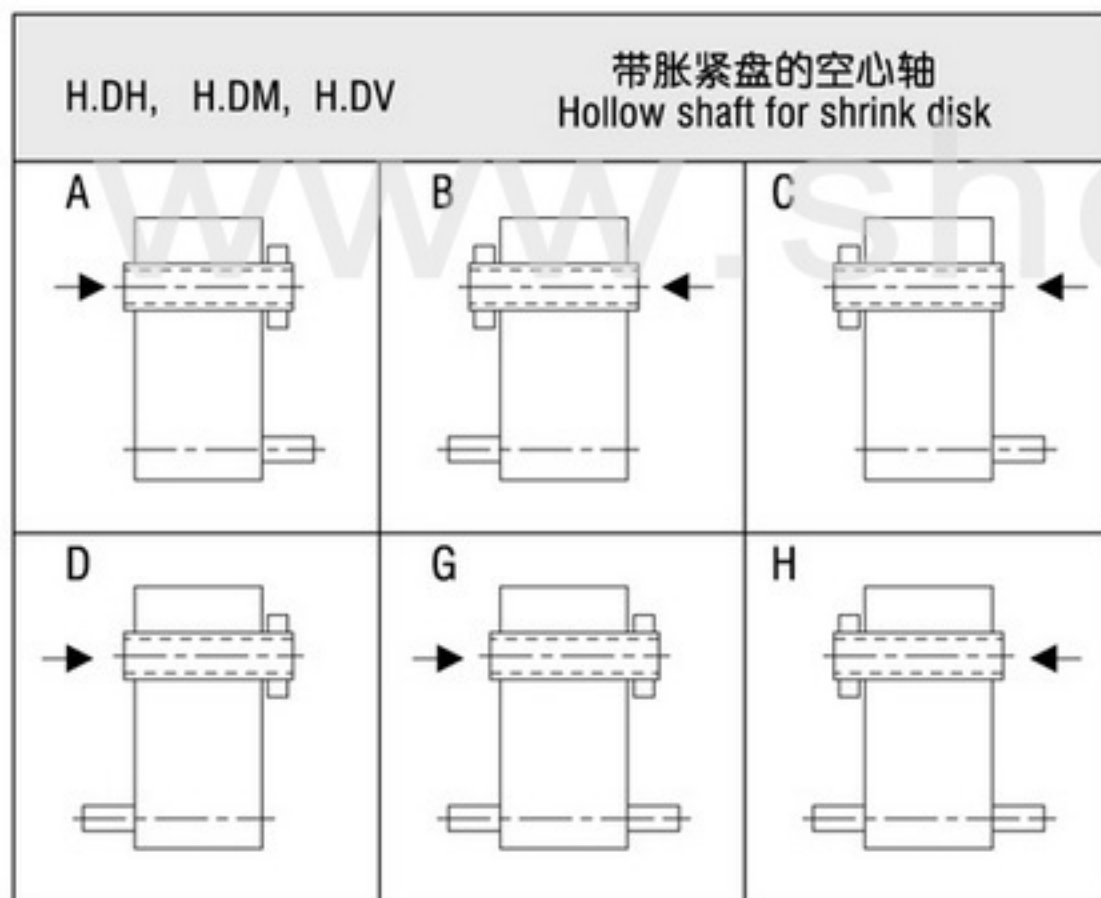
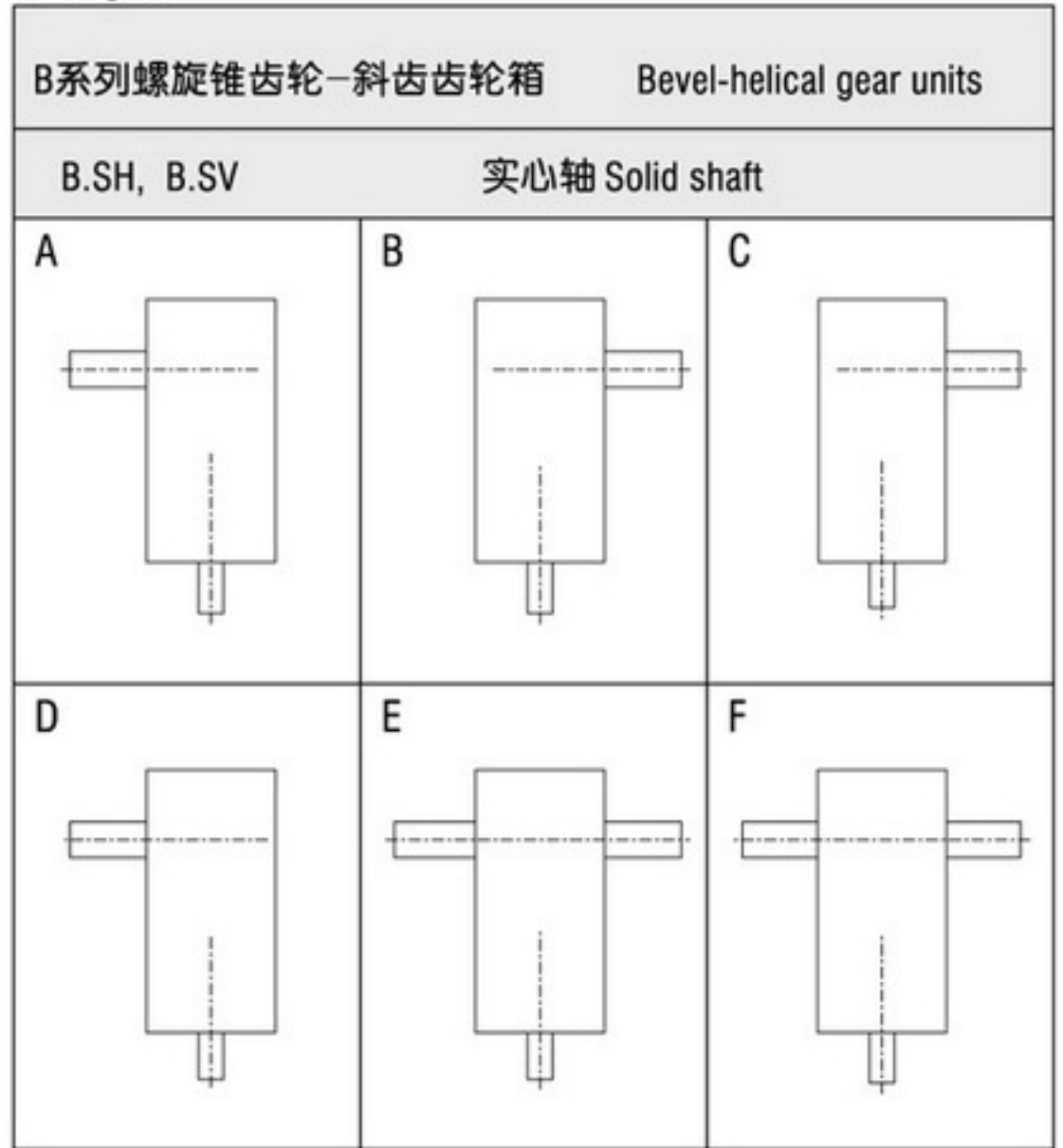

注: 箭头表示工作机驱动轴插入方向。

Note: The arrow indicates the direction of insertion of the driven machine shaft.

逆止器布置及轴旋转方向关系：

Standard backstop arrangement and dependence of direction of rotation:

Type	Sizes 3 ... 14				Sizes 15 ... 18			
	A	B	C	D	A	B	C	D
B2SH								
B2HH B2HM								
B2DH B2DM								

Type	Sizes 3 ... 18				Sizes 19 ... 22			
	A	B	C	D	A	B	C	D
B3SH								
B3HH B3HM								
B3DH B3DM								

带胀紧盘和平键联接的空心轴尺寸图表:
带胀紧盘联接的空心轴尺寸图表:

Hollow Shafts for Shrink Disks and Parallel Key Connections:
Hollow Shafts for Shrink Disks:

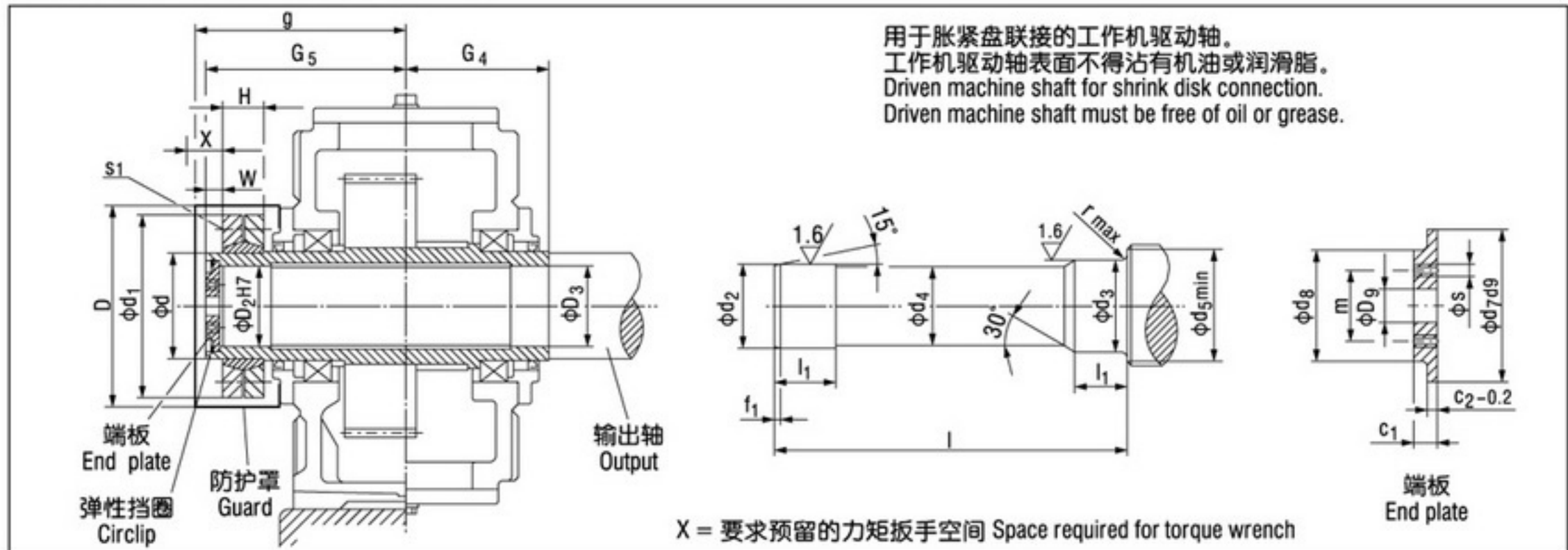

类型H2D., H3D., H4D., B3D., B4D. (规格4~22)

Type H2D., H3D., H4D., B3D., B4D. (Size 4 ~ 22)

齿轮箱 型号 Gear unit size	工作机驱动轴 Driven machine shaft 2)															弹性 挡圈 Circlip	空心轴 Hollow shaft				胀紧盘 Shrink disk 1)				螺钉 Screw	防护罩 Guard			
	d ₂	d ₃	d ₄	d ₅	f ₁	l	l ₁	r	c ₁	c ₂	d ₇	d ₈	D ₉	m	s		数量 Qty.	D ₂	D ₃	G ₄	G ₅	Type	d	d ₁		H	W	s ₁	D
4	85 g6	85 h6	84.5	95	4	326	48	2	17	7	90	70	22	50	M 8	2	90 x 3	85	85	140	205	SP2-110	110	185	49	20	M 12	235	220
5	100 g6	100 h6	99.5	114	5	383	53	2	20	8	105	80	26	55	M 10	2	105 x 4	100	100	165	240	SP2-125	125	215	53	20	M 12	275	255
6	110 g6	110 h6	109.5	124	5	383	58	3	20	8	115	85	26	60	M 10	2	115 x 4	110	110	165	240	SP2-140	140	230	58	20	M 14	285	255
7	120 g6	120 h6	119.5	134	5	453	68	3	20	8	125	90	26	65	M 12	2	125 x 4	120	120	195	280	SP2-155	155	263	62	23	M 14	330	295
8	130 g6	130 h6	129.5	145	6	458	73	3	20	8	135	100	26	70	M 12	2	135 x 4	130	130	195	285	SP2-165	165	290	68	23	M 16	340	300
9	140 g6	140 m6	139.5	160	6	539	82	4	23	10	150	110	33	80	M 12	2	150 x 4	140	140	235	330	SP2-175	175	300	68	28	M 16	360	345
10	150 g6	150 m6	149.5	170	6	559	92	4	23	10	160	120	33	90	M 12	2	160 x 4	150	150	235	350	SP2-200	200	340	85	28	M 16	395	365
11	165 f6	165 m6	164.5	185	7	644	112	4	23	10	175	130	33	90	M 12	2	175 x 4	165	165	270	400	SP2-220	220	370	103	30	M 20	435	420
12	180 f6	180 m6	179.5	200	7	649	122	4	23	10	190	140	33	100	M 16	2	190 x 4	180	180	270	405	SP2-240	240	405	107	30	M 20	450	420
13	190 f6	190 m6	189.5	213	7	789	137	5	23	10	200	150	33	110	M 16	2	200 x 4	190	190	335	480	SP2-260	260	430	119	30	M 20	500	505
14	210 f6	210 m6	209.5	233	8	784	147	5	28	14	220	170	33	130	M 16	2	220 x 5	210	210	335	480	SP2-280	280	460	132	30	M 20	525	505
15	230 f6	230 m6	229.5	253	8	899	157	5	28	14	240	180	39	140	M 16	2	240 x 5	230	230	380	550	SP2-300	300	485	140	35	M 24	575	575
16	240 f6	240 m6	239.5	263	8	899	157	5	28	14	250	190	39	150	M 20	2	250 x 5	240	240	380	550	SP2-320	320	520	140	35	M 24	595	575
17	250 f6	250 m6	249.5	278	8	982	177	5	30	14	265	200	39	150	M 20	2	265 x 5	250	250	415	600	SP2-340	340	570	155	35	M 24	615	630
18	280 f6	280 m6	279.5	306	9	982	177	5	30	14	290	210	39	160	M 20	2	290 x 5	280	280	415	600	SP2-360	360	590	162	35	M 24	635	625
19	285 f6	285 m6	284.5	316	9	1100	187	5	32	15	300	220	39	170	M 24	2	300 x 5	285	285	465	670	SP2-380	380	640	166	40	M 27	■	■
20	310 f6	310 m6	309.5	336	9	1100	187	5	32	15	320	230	39	180	M 24	2	320 x 6	310	310	465	670	SP2-390	390	650	166	40	M 27	■	■
21	330 f6	330 m6	329	358	9	1160	205	5	40	20	340	250	45	190	M 24	2	340 x 6	330	330	490	715	SP2-420	420	670	186	45	M 27	■	■
22	340 f6	340 m6	339	368	9	1170	215	5	40	20	350	260	45	200	M 24	2	350 x 6	340	340	490	725	SP2-440	440	720	194	45	M 27	■	■
23, 24 25, 26	按客户要求供货 On request																												

类型B2D. (规格4~18)

Type B2D. (Size 4 ~ 18)

齿轮箱 型号 Gear unit size	工作机驱动轴 Driven machine shaft 2)															弹性 挡圈 Circlip	空心轴 Hollow shaft				胀紧盘 Shrink disk 1)				螺钉 Screw	防护罩 Guard			
	d ₂	d ₃	d ₄	d ₅	f ₁	l	l ₁	r	c ₁	c ₂	d ₇	d ₈	D ₉	m	s		数量 Qty.	D ₂	D ₃	G ₄	G ₅	Type	d	d ₁		H	W	s ₁	D
4	85 g6	85 h6	84.5	95	4	386	48	2	17	7	90	70	22	50	M 8	2	90 x 3	85	85	170	235	SP2-110	110	185	49	20	M 12	235	250
5	100 g6	100 h6	99.5	114	5	453	53	2	20	8	105	80	26	55	M 10	2	105 x 4	100	100	200	275	SP2-125	125	215	53	20	M 12	275	285
6	110 g6	110 h6	109.5	124	5	453	58	3	20	8	115	85	26	60	M 10	2	115 x 4	110	110	200	275	SP2-140	140	230	58	20	M 14	285	285
7	120 g6	120 h6	119.5	134	5	533	68	3	20	8	125	90	26	65	M 12	2	125 x 4	120	120	235	320	SP2-155	155	263	62	23	M 14	330	335
8	130 g6	130 h6	129.5	145	6	538	73	3	20	8	135	100	26	70	M 12	2	135 x 4	130	130	235	325	SP2-165	165	290	68	23	M 16	340	340
9	140 g6	140 m6	139.5	160	6	609	82	4	23	10	150	110	33	80	M 12	2	150 x 4	140	140	270	365	SP2-175	175	300	68	28	M 16	360	380
10	150 g6	150 m6	149.5	170	6	629	92	4	23	10	160	120	33	90	M 12	2	160 x 4	150	150	270	385	SP2-200	200	340	85	28	M 16	395	400
11	165 f6	165 m6	164.5	185	7	744	112	4	23	10	175	130	33	90	M 12	2	175 x 4	165	165	320	450	SP2-220	220	370	103	30	M 20	435	470
12	180 f6	180 m6	179.5	200	7	749	122	4	23	10	190	140	33	100	M 16	2	190 x 4	180	180	320	455	SP2-240	240	405	107	30	M 20	450	470
14	210 f6	210 m6	209.5	233	8	894	147	5	28	14	220	170	33	130	M 16	2	220 x 5	210	210	390	535	SP2-280	280	460	132	30	M 20	525	555
16	240 f6	240 m6	239.5	263	8	1039	157	5	28	14	250	190	39	150	M 20	2	250 x 5	240	240	450	620	SP2-320	320	520	140	35	M 24	595	645
18	280 f6	280 m6	279.5	306	9	1177	177	5	30	14	290	210	39	160	M 20	2	290 x 5	280	280	510	700	SP2-360	360	590	162	35	M 24	635	725

1) 胀紧盘不在我们的供货范围之内。如果需要的话, 请另行订货。
2) 工作机驱动轴材质: 40Cr或强度更高的钢。工作机驱动轴不在供货范围之内, 但尺寸函索即复。

1) Shrink disk does not belong to our scope of supply. Please order separately, if required.
2) Material of driven machine shaft: 40Cr or higher strength. Driven machine shaft does not belong to our scope of supply. Shrink disk is supplied as loose item, dimensions of machine shaft on request.

带平键联接的空心轴尺寸图表:

Hollow Shafts for flat key:

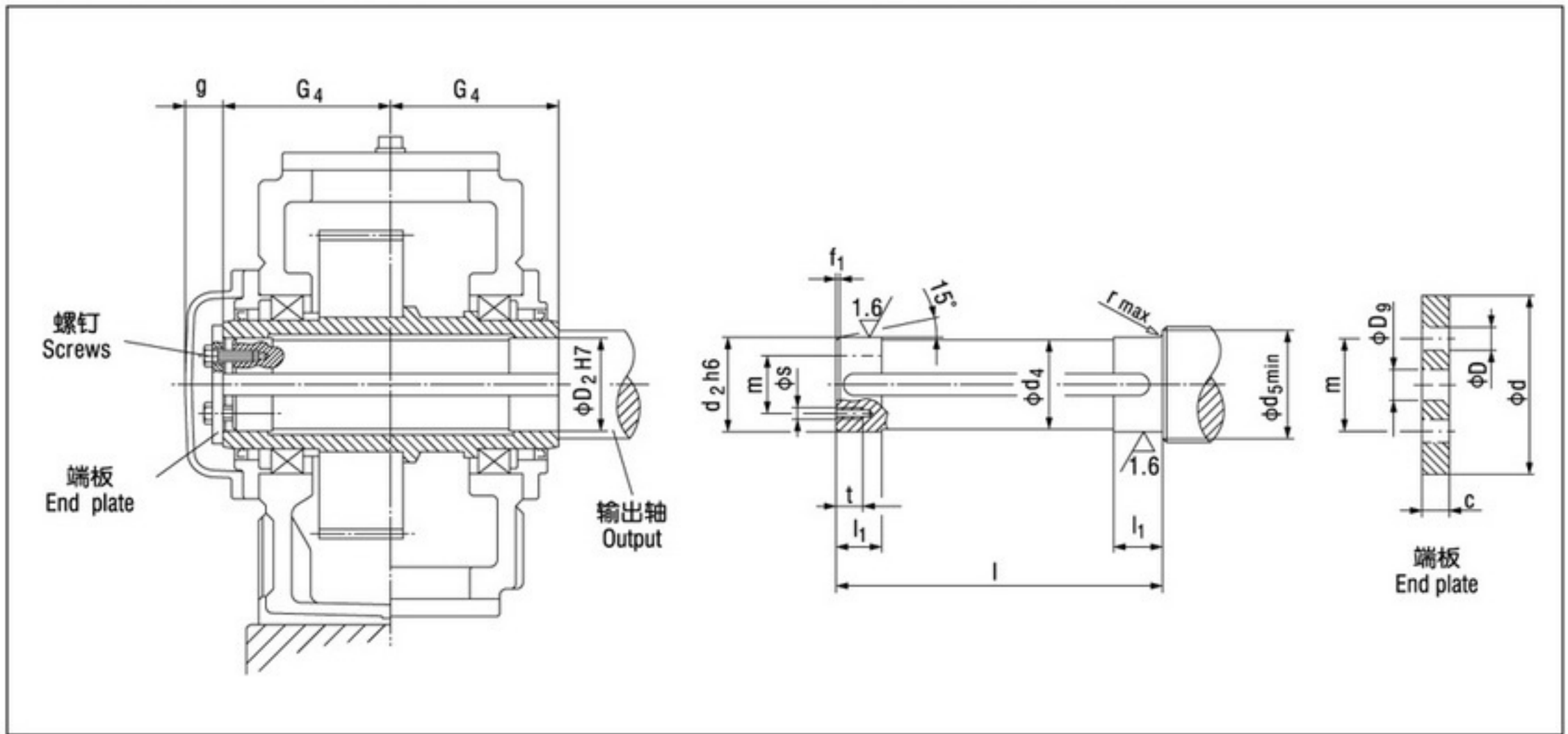

类型H2H., H3H., H4H., B3H., B4H. (规格4~18)

Type H2H., H3H., H4H., B3H., B4H. (Size 4 ~ 18)

齿轮箱 型号 Gear unit size	工作机驱动轴 Driven machine shaft									端板 End plate				螺钉 Screw		空心轴 Hollow shaft			
	d ₂	d ₄	d ₅	f ₁	l	l ₁	r	s	t	c	D	D _g	d	m	规格Size	数量Qty.	D ₂	G ₄	g
4	80	79.5	88	4	278	35	1.2	M 10	18	10	11	22	100	60	M 10 x 25	2	80	140	35
5	95	94.5	105	5	328	40	1.6	M 10	18	10	11	26	120	70	M 10 x 25	2	95	165	40
6	105	104.5	116	5	328	45	1.6	M 10	18	10	11	26	120	70	M 10 x 25	2	105	165	40
7	115	114.5	126	5	388	50	1.6	M 12	20	12	13.5	26	140	80	M 12 x 30	2	115	195	40
8	125	124.5	136	6	388	55	2.5	M 12	20	12	13.5	26	150	85	M 12 x 30	2	125	195	40
9	135	134.5	147	6	467	60	2.5	M 12	20	12	13.5	33	160	90	M 12 x 30	2	135	235	45
10	150	149.5	162	6	467	65	2.5	M 12	20	12	13.5	33	185	110	M 12 x 30	2	150	235	45
11	165	164.5	177	7	537	70	2.5	M 16	28	15	17.5	33	195	120	M 16 x 40	2	165	270	45
12	180	179.5	192	7	537	75	2.5	M 16	28	15	17.5	33	220	130	M 16 x 40	2	180	270	45
13	190	189.5	206	7	667	80	3	M 16	28	18	17.5	33	230	140	M 16 x 40	2	190	335	45
14	210	209.5	226	8	667	85	3	M 16	28	18	17.5	33	250	160	M 16 x 40	2	210	335	45
15	230	229.5	248	8	756	100	3	M 20	38	25	22	39	270	180	M 20 x 55	4	230	380	60
16	240	239.5	258	8	756	100	3	M 20	38	25	22	39	280	180	M 20 x 55	4	240	380	60
17	250	249.5	270	8	826	110	4	M 20	38	25	22	39	300	190	M 20 x 55	4	250	415	60
18	275	274.5	295	9	826	120	4	M 20	38	25	22	39	330	210	M 20 x 55	4	275	415	60

类型B2H. (规格4~18)

Type B2H. (Size 4 ~ 18)

齿轮箱 型号 Gear unit size	工作机驱动轴 Driven machine shaft									端板 End plate				螺钉 Screw		空心轴 Hollow shaft			
	d ₂	d ₄	d ₅	f ₁	l	l ₁	r	s	t	c	D	D _g	d	m	规格Size	数量Qty.	D ₂	G ₄	g
4	80	79.5	88	4	338	35	1.2	M 10	18	10	11	22	100	60	M 10 x 25	2	80	170	35
5	95	94.5	105	5	398	40	1.6	M 10	18	10	11	26	120	70	M 10 x 25	2	95	200	40
6	105	104.5	116	5	398	45	1.6	M 10	18	10	11	26	120	70	M 10 x 25	2	105	200	40
7	115	114.5	126	5	468	50	1.6	M 12	20	12	13.5	26	140	80	M 12 x 30	2	115	235	40
8	125	124.5	136	6	468	55	2.5	M 12	20	12	13.5	26	150	85	M 12 x 30	2	125	235	40
9	135	134.5	147	6	537	60	2.5	M 12	20	12	13.5	33	160	90	M 12 x 30	2	135	270	45
10	150	149.5	162	6	537	65	2.5	M 12	20	12	13.5	33	185	110	M 12 x 30	2	150	270	45
11	165	164.5	177	7	637	70	2.5	M 16	28	15	17.5	33	195	120	M 16 x 40	2	165	320	45
12	180	179.5	192	7	637	75	2.5	M 16	28	15	17.5	33	220	130	M 16 x 40	2	180	320	45
14	210	209.5	226	8	777	85	3	M 16	28	18	17.5	33	250	160	M 16 x 40	2	210	390	45
16	240	239.5	258	8	896	100	3	M 20	38	25	22	39	280	180	M 20 x 55	4	240	450	60
18	275	274.5	295	9	1016	120	4	M 20	38	25	22	39	330	210	M 20 x 55	4	275	510	60

1) 工作机驱动轴材质: 40Cr或强度更高的钢。
2) 工作机驱动轴及平键不在我们的供货范围之内。
如果需要的话, 请另订货。

1) Material of driven machine shaft: 40Cr or higher strength.
2) Parallel key does not belong to our scope of supply.
Please order separately, if required.

带法兰轴：

With Flanged Shaft d_2 :

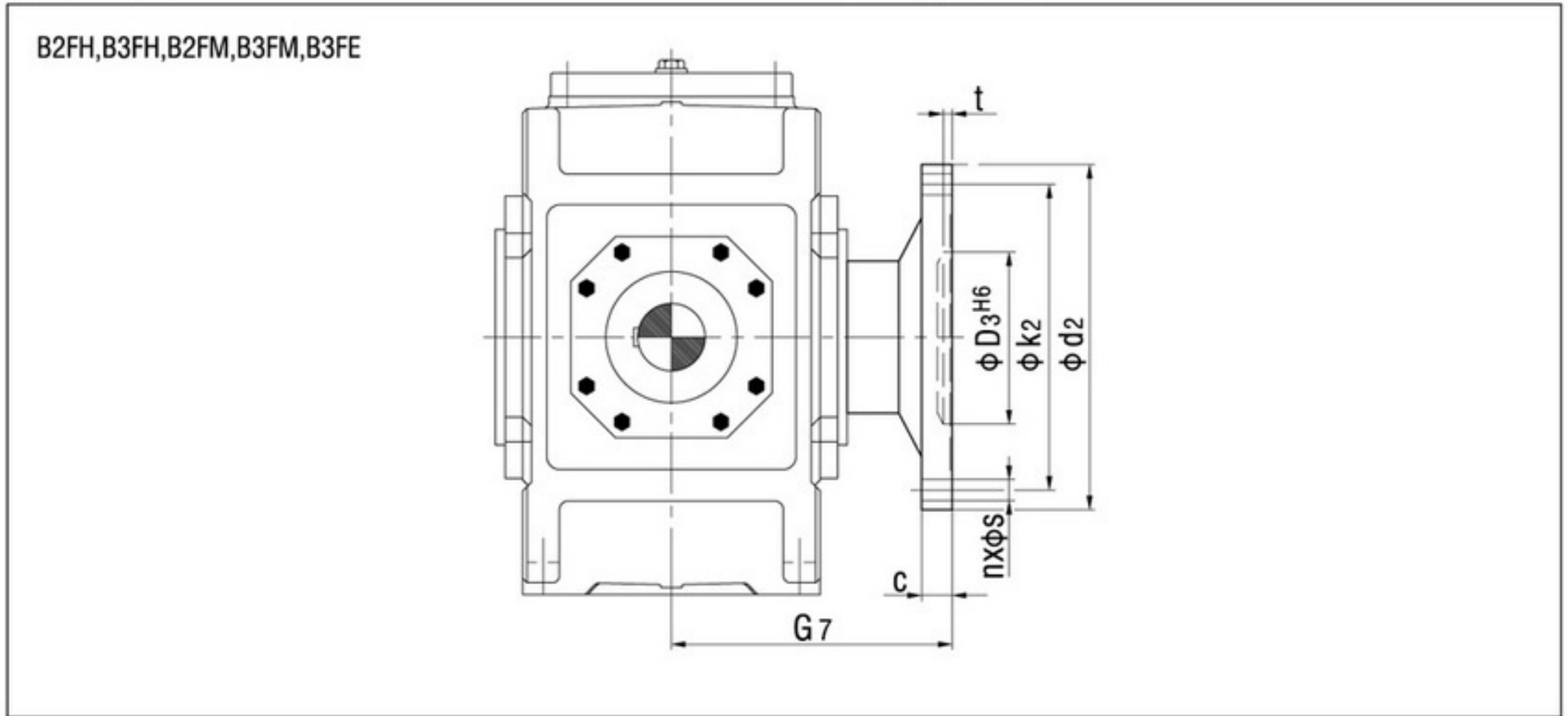

Gear unit size	c	d_2	D_3	k_2	n	s	t	B3F.		B2F.		
								G 7	add. weight	G 7	add. weight	
5	25	300	150	260	16	22	10	255	35	290	40	
6	25	320	160	280	18	22	10	255	40	290	45	
7	30	370	180	320	16	26	10	300	50	340	55	
8	30	390	190	340	18	26	10	300	55	340	60	
9	38	430	220	380	20	26	12	350	85	385	90	
10	38	470	240	420	22	26	12	350	90	385	95	
11	42	510	260	450	18	33	12	400	130	450	135	
12	42	540	280	480	22	33	12	400	140	450	150	
13	48	580	310	500	20	33	14	480	160	525	170	
14	48	620	310	540	24	33	14	480	170	525	180	
15	55	710	360	630	28	33	17	550	240	625	255	
16	55	740	360	660	30	33	17	550	255	625	270	
17	60	750	410	660	24	39	18	600	300	695	320	
18	60	800	410	710	26	39	18	600	350	695	370	
19	65	860	460	770	30	39	18	670	按客户要求供货 On request	——	——	
20	65	930	460	830	32	39	18	670				
21	75	950	520	850	28	45	20	710				
22	75	1040	520	940	28	45	20	710				
23,24,25,26	按客户要求供货							On request				

齿轮箱冷却盘管尺寸图:
卧式安装:

Gear Units Cooling Coils:
Horizontal:

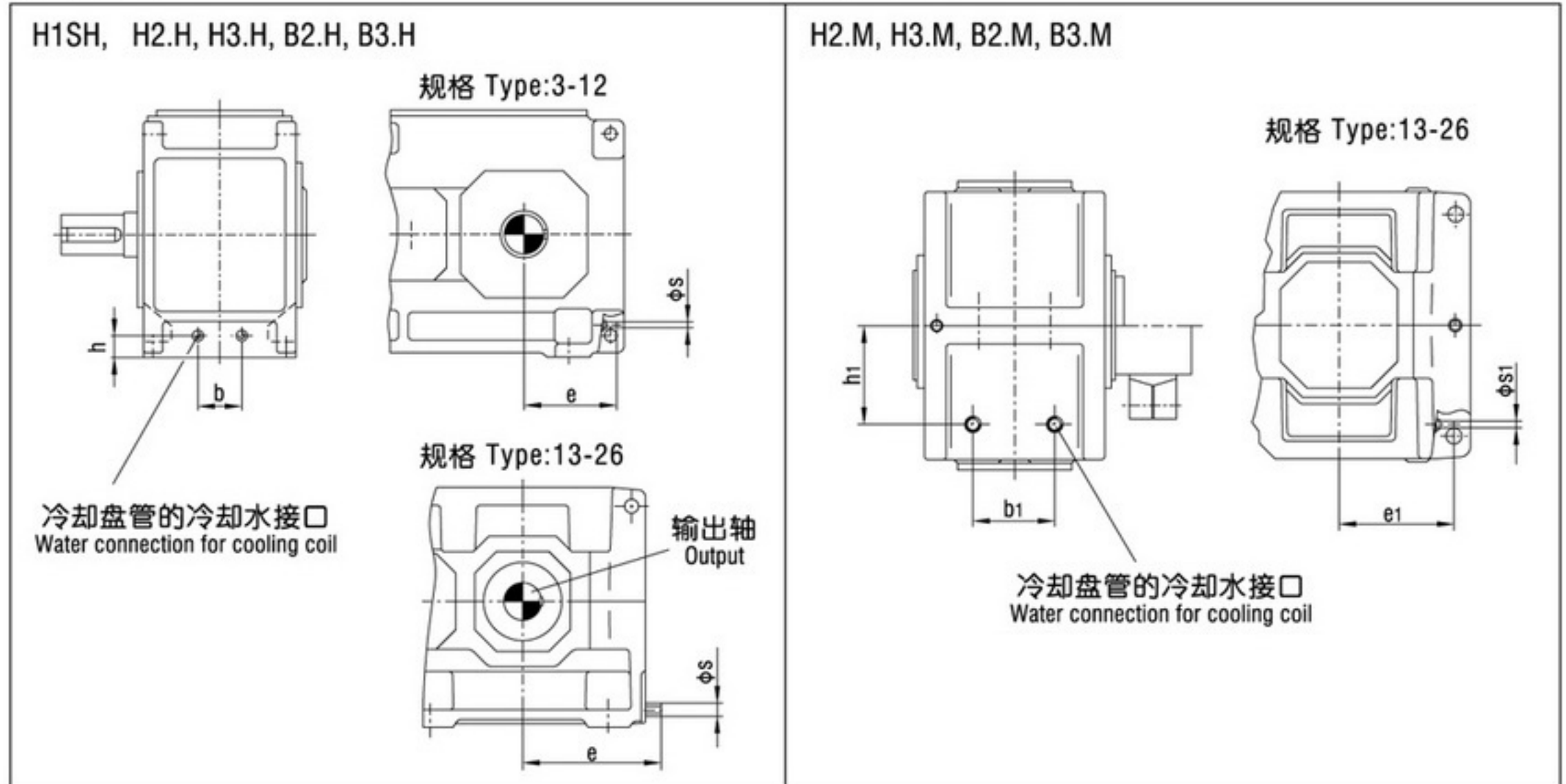

型号 Size	H1SH					H2.H / B3.H					H3.H					B2.H					
	b	e	h	s	水量 Water quantity (l)	b	e	h	s	水量 Water quantity (l)	b	e	h	s	水量 Water quantity (l)	b	e	h	s	水量 Water quantity (l)	
3	48	205	74	G 1/2	4	-	-	-	-	-	-	-	-	-	-	-	-	-	-	-	-
4	-	-	-	-	-	34	155	60	G 1/2	4	-	-	-	-	-	74	160	54	G 1/2	4	-
5	88	270	90	G 1/2	4	68	170	64	G 1/2	4	70	175	60	G 1/2	4	130	175	62	G 1/2	8	-
6	-	-	-	-	-	70	215	68	G 1/2	4	70	220	69	G 1/2	4	120	220	68	G 1/2	4	-
7	124	310	135	G 1/2	4	100	210	83	G 1/2	4	80	210	83	G 1/2	4	140	210	80	G 1/2	8	-
8	-	-	-	-	-	100	270	83	G 1/2	4	80	270	83	G 1/2	4	140	270	80	G 1/2	4	-
9	116	365	110	G 1/2	8	140	245	110	G 1/2	8	150	245	107	G 1/2	4	232	245	110	G 1/2	8	-
10	-	-	-	-	-	100	295	95	G 1/2	8	90	295	95	G 1/2	4	150	295	90	G 1/2	8	-
11	146	425	130	G 1/2	8	110	275	95	G 1/2	8	200	275	115	G 1/2	8	312	275	115	G 1/2	8	-
12	-	-	-	-	-	200	360	109	G 1/2	8	200	360	115	G 1/2	8	300	360	115	G 1/2	8	-
13	152	480	150	G 1/2	8	252	455	116	G 1/2	8	252	460	116	G 1/2	8	324	460	116	G 1/2	8	-
14	-	-	-	-	-	252	525	116	G 1/2	8	252	530	116	G 1/2	8	324	530	116	G 1/2	8	-
15	172	560	130	G 1/2	8	290	535	119	G 1/2	8	290	540	119	G 1/2	8	396	540	119	G 1/2	8	-
16	-	-	-	-	-	290	580	119	G 1/2	8	290	585	119	G 1/2	8	396	585	119	G 1/2	8	-
17	202	600	145	G 1/2	8	340	575	134	G 1/2	8	300	580	134	G 1/2	8	468	580	134	G 1/2	8	-
18	-	-	-	-	-	340	635	134	G 1/2	8	300	640	134	G 1/2	8	468	640	134	G 1/2	8	-
19	按客户要求供货 On request					按客户要求供货 On request					按客户要求供货 On request										
20 - 26	-					按客户要求供货 On request					按客户要求供货 On request										

型号 Size	H2.M / B3.M					H3.M					B2.M				
	b1	e1	h1	s1	水量 Water quantity (l)	b1	e1	h1	s1	水量 Water quantity (l)	b1	e1	h1	s1	水量 Water quantity (l)
13	252	335	300	G 1/2	8	252	335	300	G 1/2	8	324	335	300	G 1/2	8
14	252	405	300	G 1/2	8	252	405	300	G 1/2	8	324	405	300	G 1/2	8
15	290	395	335	G 1/2	8	290	395	340	G 1/2	8	396	390	345	G 1/2	8
16	290	440	335	G 1/2	8	290	440	340	G 1/2	8	396	435	345	G 1/2	8
17	340	425	380	G 1/2	8	300	425	380	G 1/2	8	324	425	395	G 1/2	8
18	340	485	380	G 1/2	8	300	485	380	G 1/2	8	324	485	395	G 1/2	8
19 - 26	按客户要求供货 On request					按客户要求供货 On request					-				

注：冷却盘管适用于淡水、海水和半咸水。

Note: Cooling Coil suitable for fresh, sea and Brackish water.

立式安装:

Vertical:

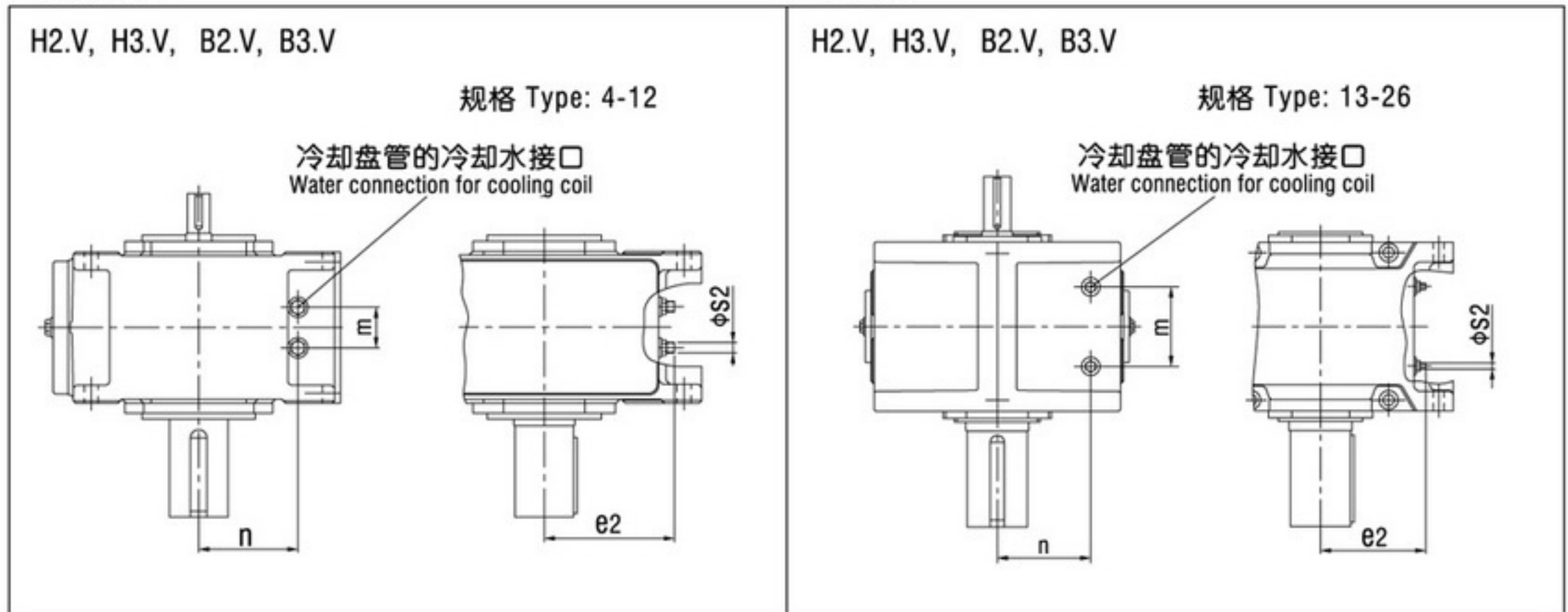

型号 Size	H2.V / B3.V					H3.V					B2.V				
	m	n	e2	s2	水量 Water quantity (l)	m	n	e2	s2	水量 Water quantity (l)	m	n	e2	s2	水量 Water quantity (l)
4	34	140	155	G 1/2	4	-	-	-	-	-	74	146	160	G 1/2	4
5	68	166	170	G 1/2	4	70	170	175	G 1/2	4	130	168	175	G 1/2	8
6	70	162	215	G 1/2	4	70	161	220	G 1/2	4	120	162	220	G 1/2	4
7	100	197	210	G 1/2	4	80	197	210	G 1/2	4	140	200	210	G 1/2	8
8	100	197	270	G 1/2	4	80	197	270	G 1/2	4	140	200	270	G 1/2	4
9	140	210	245	G 1/2	8	150	213	245	G 1/2	4	232	210	245	G 1/2	8
10	100	225	295	G 1/2	8	90	225	295	G 1/2	4	150	230	295	G 1/2	8
11	110	285	275	G 1/2	8	200	265	275	G 1/2	8	312	265	275	G 1/2	8
12	200	271	360	G 1/2	8	200	265	360	G 1/2	8	300	265	360	G 1/2	8
13	252	300	335	G 1/2	8	252	300	335	G 1/2	8	324	300	335	G 1/2	8
14	252	300	405	G 1/2	8	252	300	405	G 1/2	8	324	300	405	G 1/2	8
15	290	335	395	G 1/2	8	290	340	395	G 1/2	8	396	345	390	G 1/2	8
16	290	335	440	G 1/2	8	290	340	440	G 1/2	8	396	345	435	G 1/2	8
17	340	380	425	G 1/2	8	300	380	425	G 1/2	8	324	395	425	G 1/2	8
18	340	380	485	G 1/2	8	300	380	485	G 1/2	8	324	395	485	G 1/2	8
19-26	按客户要求供货 On request					按客户要求供货 On request					-				

类型 Type	型号 Size	冷却盘管适用于 Cooling coil for											
		浸油润滑 Dip lubrication				法兰泵强制润滑 Forced lubrication with flanged-on pump				电动泵强制润滑 Forced lubrication with motor pump			
		适用布置形式 For design				适用布置形式 For design				适用布置形式 For design			
		A	B	C	D	A	B	C	D	A	B	C	D
H2.V	4	√	√	√	√	-	-	-	-	按客户要求供货 On request			
	5-12	√	√	√	√	-	√	-	√				
	13-18	-	-	-	-	-	√	-	√				
H3.V	5-12	√	√	√	√	-	√	-	√				
	13-18	-	-	-	-	-	√	-	√				
B2.V	4	√	√	√	√	-	-	-	-				
	5-12	√	√	√	√	√	√	-	-				
	13-18	-	-	-	-	√	√	-	-				
B3.V	4	√	√	√	√	-	-	-	-				
	5-12	√	√	√	√	-	-	√	√				
	13-18	-	-	-	-	-	-	√	√				

注: 冷却盘管适用于淡水、海水和半咸水。

Note: Cooling Coil suitable for fresh, sea and Brackish water.

润滑油供给方式可选方案（立式安装）

Gear Units Oil Supply for Vertical:

立式安装齿轮箱所用的各种润滑油供给方式见下表1

Oil supply variants for vertical gear units can be derived from table1.

类别 Type	型号 Size	浸油润滑 Dip lubrication	法兰泵强制润滑 Forced lubrication, flanged-on pump	电动泵强制润滑 Forced lubrication, motor pump
H2.V	4	✓	—	—
	5 ... 12	✓	✓	—
	13 ... 18	—	✓	—
H3.V	5 ... 12	✓	✓	✓
	13 ... 18	—	✓	✓
H4.V	7 ... 12	✓	✓	✓
	13 ... 18	—	—	✓
B2.V	4	✓	—	—
	5 ... 12	✓	✓	✓
	13 ... 18	—	✓	✓
B3.V	4	✓	—	—
	5 ... 12	✓	✓	✓
	13 ... 18	—	✓	✓
B4.V	5 ... 12	✓	✓	✓
	13 ... 18	—	—	✓

*推荐供油方式:

型号6及以下各型: 浸油润滑
型号7及以上各型: 强制润滑

Preferred order:

Up to size 6: Dip Lubrication
From size 7 up: Forced Lubrication

注: 对各种润滑油供给方式的说明:

浸油润滑:

浸油润滑时, 所有需要润滑的零部件均需浸在润滑油中。附带的补偿油箱用于存储涨溢的油液。

强制润滑:

当采用强制时, 所有未浸在润滑油液中的零部件均通过一个法兰联接油泵或单独的电动油泵进行飞溅润滑。

Notes on the individual oil supply variants:

Dip lubrication:

In case of dip lubrication, all parts to be lubricated are lying in the oil. An oil compensating tank has been fitted for oil expansion. Criteria for selection.

Forced lubrication:

In case of forced lubrication, all parts which are not lying in oil are splash lubricated by means of a flanged-on pump or by a separate motor pump.

当选用浸油润滑方式时, 必须满足下列要求:

- a) 允许油温, 参见表2;
- b) 最大输入转速n1, 参见表3。

For the design with dip lubrication the following criteria have to be observed:

- a) Permissible oil temperatures, see table 2
- b) Maximum input speed n1, see table 3

40℃温度下的 ISO-VG 粘度 Viscosity ISO-VG at 40℃ mm ² /s(cSt)	浸油润滑允许极限温度 ℃ Permissible temperature limit in ℃ for dip lubrication	
	矿物油 Mineral oil	合成油 Synthetic oil
VG 220	- 15	- 25
VG 320	- 12	- 22
VG 460	- 9	- 25

若油温低于表中所示数值, 则必须对润滑油进行加热。当采用浸油润滑时, 油温不得低于所用润滑油的倾点。

If the temperatures are below the values as listed in the table, the oil must be heated. In case of dip lubrication, the oil temperature must not be below the pour point of the selected oil.

Size	H2.V		H3.V		H4.V		B2.V		B3.V		B4.V	
	i_N	n_{1max}	i_N	n_{1max}	i_N	n_{1max}	i_N	n_{1max}	i_N	n_{1max}	i_N	n_{1max}
4	6.3-10 11.2-12.5 14-22.4	1200 1500 1800	—	—	—	—	5-5.6 6.3-7.1 8-9 10-11.2	750 900 1000 1200	12.5-71	1800	—	—
5	6.3-9 10-12.5 14-16 18-22.4	1000 1200 1500 1800	25-90	1800	—	—	6.3-7.1 8-9 10-11.2	750 900 1000	12.5-71	1800	80-315	1800
6	8-11.2 12.5-16 18-20 22.4-28	1000 1200 1500 1800	31.5-112	1800	—	—	9 10-11.2 12.5-14	750 900 1000	16-90	1800	100-400	1800
7	6.3-7.1 8-9 10-11.2 12.5-18 18-22.4	750 900 1000 1200 1500	25-90	1800	100-355	1800	9-10 11.2	750 900	12.5-25 28-71	1500 1800	80-315	1800
8	8-9 10-11.2 12.5-14 16-20 22.4-28	750 900 1000 1200 1500	31.5-112	1800	125-450	1800	11.2-12.5 14	750 900	16-31.5 35.5-90	1500 1800	100-400	1800
9	6.3-7.1 8-10 11.2-22.4	1200 1500 1800	25-90	1800	100-355	1800	5-5.6 6.3-7.1 8-10 11.2	900 1000 1200 1500	12.5-71	1800	80-315	1800
10	8-9 10-12.5 14-28	1200 1500 1800	31.5-112	1800	125-450	1800	6.3-7.1 8-9 10-12.5 14	900 1000 1200 1500	16-90	1800	100-400	1800
11	6.3-7.1 8-10 11.2-12.5 14-22.4	1000 1200 1500 1800	25-90	1800	100-355	1800	5.6-6.3 7.1-8 9-10 11.2	750 900 1000 1200	12.5-22.4 25-71	1500 1800	80-315	1800
12	8-9 10-12.5 14-16 18-28	1000 1200 1500 1800	31.5-112	1800	125-450	1800	7.1-8 9-10 1.2-12.5 14	750 900 1000 1200	16-28 31.5-90	1500 1800	100-400	1800

注：n1和iN值不在表3所列范围内的齿轮箱必须采用强制润滑。

Note: Gear units with n1 and iN which are not listed in table 3 must be designed for forced lubrication.

当选用强制润滑方式时，允许油温见下表4：

Permissible temperature limit in °C for dip lubrication:

40℃温度下的 ISO-VG 粘度 Viscosity ISO-VG at 40℃ mm ² /s(cSt)	强制润滑允许极限温度 °C Permissible temperature limit in °C for dip lubrication			
	矿物油 Mineral oil		合成油 Synthetic oil	
	最低min.	最高max.	最低min.	最高max.
VG 220	10	80	0	90
VG 320	15	90	5	100
VG 460	20	95	10	105

强制润滑：
当采用强制润滑时，启动时的工作粘度不得超过1800cSt。
最低工作粘度不得小于25cSt。
当油温低于表4所列的数值时，必须提供浸油润滑方式，或者对润滑油进行加热。

Forced lubrication:
In case of forced lubrication, the viscosity 1800 cSt must not be exceeded during starting.
A minimum operating viscosity of 25 cSt must be ensured.
If the temperatures are below the values as listed in table 4, dip lubrication has to be provided or the oil must be heated.

齿轮箱电动泵强制润滑方式（立式安装）：

Mounted Motor Pumps (Vertical):

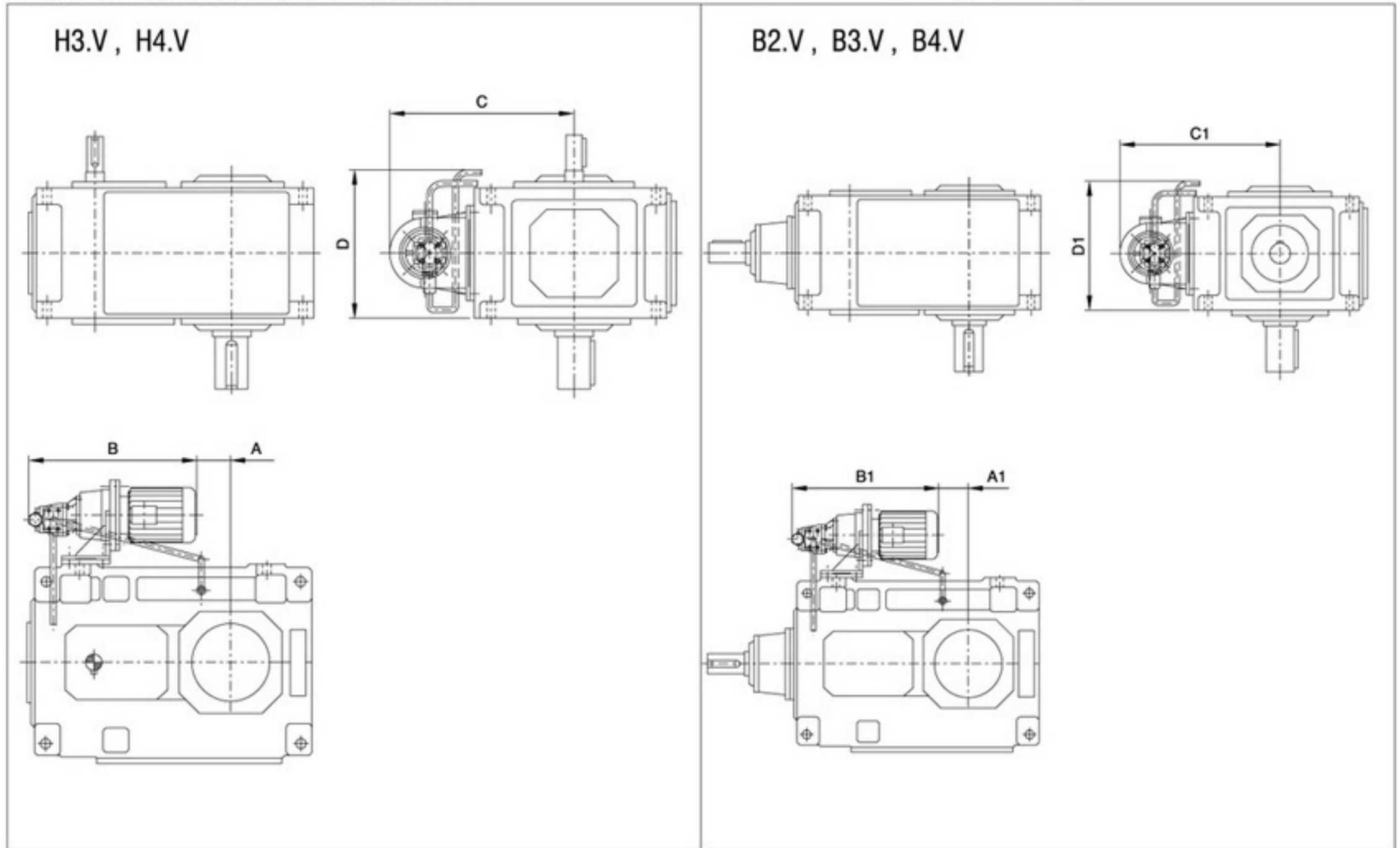

安装尺寸 Fitting dimensions							安装尺寸 Fitting dimensions						
Type	Size	Design	A	B	C	D	Type	Size	Design	A1	B1	C1	D1
H3.V	5/6	A/B/C/D	-30/5	560	480	385	B2.V	5/6	A/B/C/D	-160/-125	480	470	415
	7/8	A/B/C/D	55/100	585	550	430		7/8	A/B/C/D	5/50	480	525	510
	9/10	A/B/C/D	140/190	610	565	500		9/10	A/B/C/D	60/110	480	565	570
	11/12	A/B/C/D	375/445	530	625	560		11/12	A/B/C/D	150/220	480	625	660
	13/14	A/C	155/225	880	670	700		13/14	A/B/C/D	-70/0	755	670	805
	13/14	B/D	100/170	935	670	700		15/16	A/B/C/D	15/60	780	710	910
	15/16	A/C	275/320	965	710	770		17/18	A/B/C/D	-5/55	890	775	1025
	15/16	B/D	220/265	1020	710	770		5/6	A/B/C/D	-85/-50	480	480	365
	17/18	A/C	250/310	1040	770	835		7/8	A/B/C/D	-5/40	480	550	430
	17/18	B/D	195/255	1095	770	835		9/10	A/B/C/D	65/115	480	565	500
H4.V	7/8	A/C	55/100	600	550	430	B3.V	11/12	A/B/C/D	280/350	480	625	560
	7/8	B/D	0/45	680	550	430		13/14	A/B/C/D	35/105	810	670	700
	9/10	A/C	140/190	625	565	500		15/16	A/B/C/D	120/165	875	710	775
	9/10	B/D	85/135	705	565	500		17/18	A/B/C/D	165/225	970	775	835
	11/12	A/C	375/445	550	625	560		B4.V	5/6	A/B/C/D	-35/0	480	480
	11/12	B/D	320/390	635	625	560	7/8		A/B/C/D	55/100	480	550	430
	13/14	A/B/C/D	135/205	910	670	700	9/10		A/B/C/D	140/190	615	565	500
	15/16	A/B/C/D	255/300	1000	710	775	11/12		A/B/C/D	375/445	530	625	560
	17/18	A/B/C/D	230/290	1070	775	835	13/14		A/B/C/D	135/205	905	670	700
						15/16	A/B/C/D		255/300	990	710	775	
						17/18	A/B/C/D		230/290	1065	775	835	

HB系列产品组合及行业专用:

HB series combination and special design:

H系列斜齿齿轮箱
B系列螺旋锥齿轮-斜齿齿轮箱
Helical gear units and bevel-helical gear units

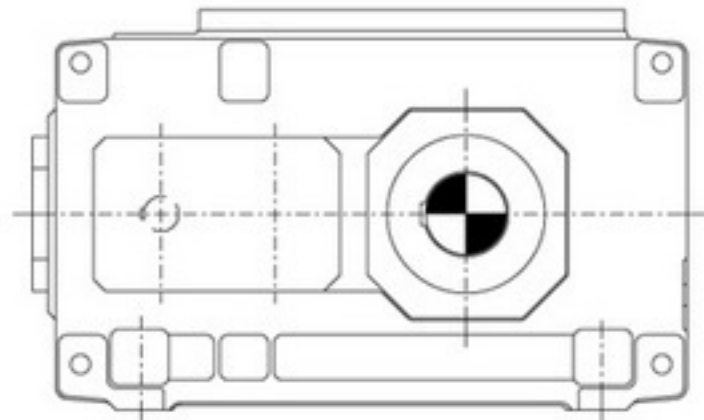

输出扭矩 Output torque: 0.62 ... 900 kNm
速比 Ratio: 1.25 ... 450
级数 Number of stages 1, 2, 3 or 4

1

H系列斜齿加长中心距齿轮箱
Helical gear units with extended total centre distance

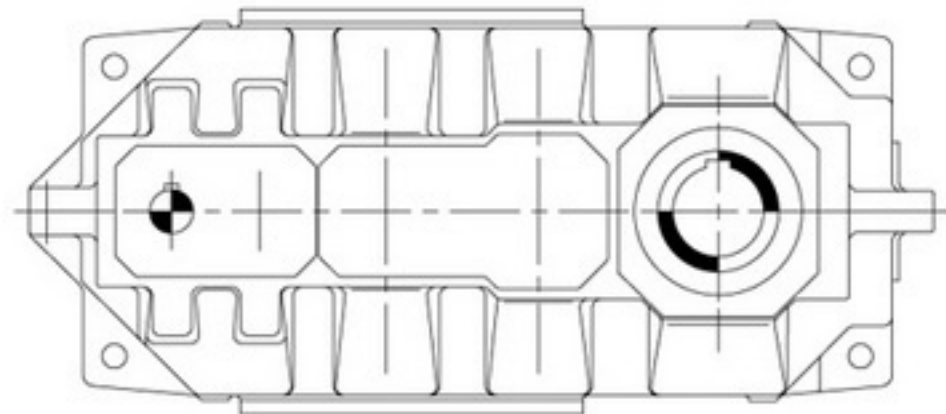

输出扭矩 Output torque: 11 ... 109 kNm
速比 Ratio: 14 ... 250
级数 No. of stages 3 or 4

2

带式输送机 Belt conveyor drives
B系列锥齿-斜齿齿轮箱 Bevel-helical gear units

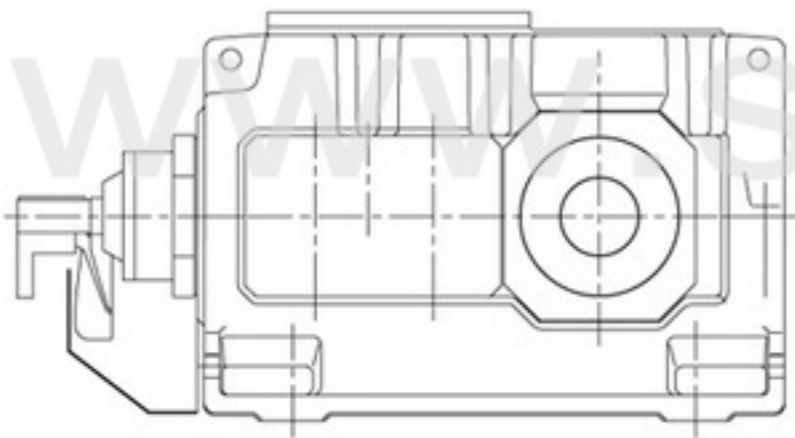

输出扭矩 Output torque: 1.03 ... 900 kNm
速比 Ratio: 5 ... 90
级数 Number of stages 2 or 3

3

行走驱动用齿轮箱 Travelling gear drives
B系列锥齿-斜齿齿轮箱 Bevel-helical gear units

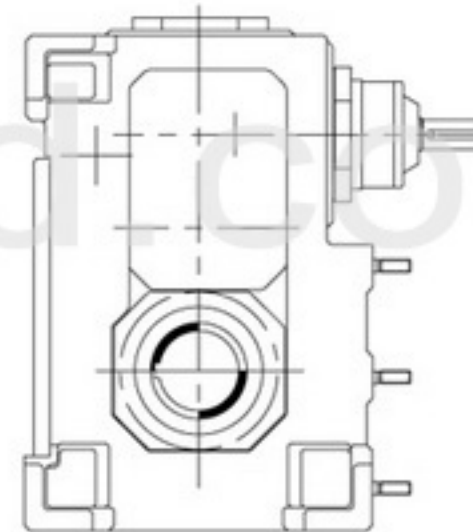

输出扭矩 Output torque: 3.6 ... 75 kNm
速比 Ratio: 12.5 ... 400
级数 Number of stages 3 or 4

4

提升机 Bucket Elevator drives
带辅助驱动的B系列 Bevel-helical gear units
锥齿-斜齿齿轮箱 with auxiliary drive

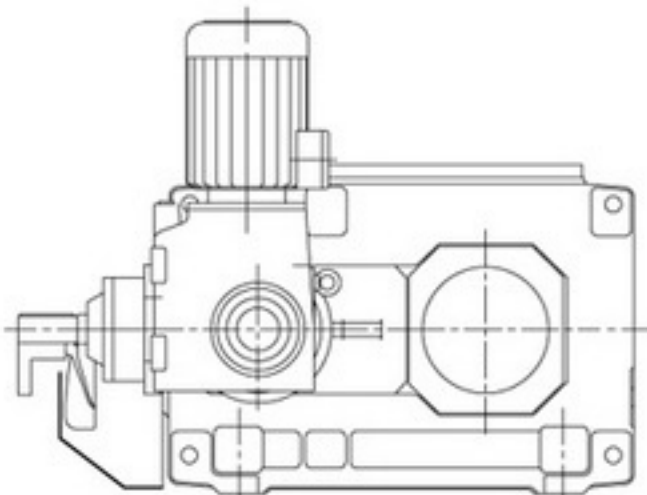

输出扭矩 Output torque: 5.5 ... 470 kNm
速比 Ratio: 12.5 ... 90
级数 Number of stages 3

5

水轮机驱动齿轮箱 Water turbine drives
H系列斜齿齿轮箱 Helical gear units and
B系列螺旋锥齿轮-斜齿齿轮箱 bevel-helical gear units

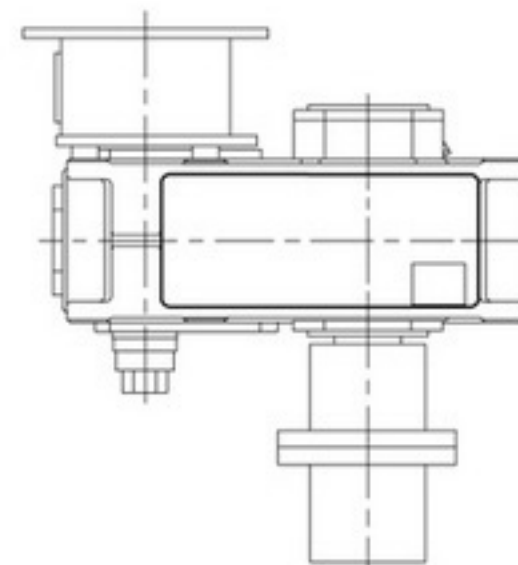

输出扭矩 Output torque: 8.5 ... 195 kNm
速比 Ratio: 5 ... 28
级数 Number of stages 2

6

冷却塔驱动齿轮箱 Cooling tower drives
H系列斜齿齿轮箱和B系列螺旋锥齿轮-斜齿齿轮箱
Helical gear units and bevel-helical gear units

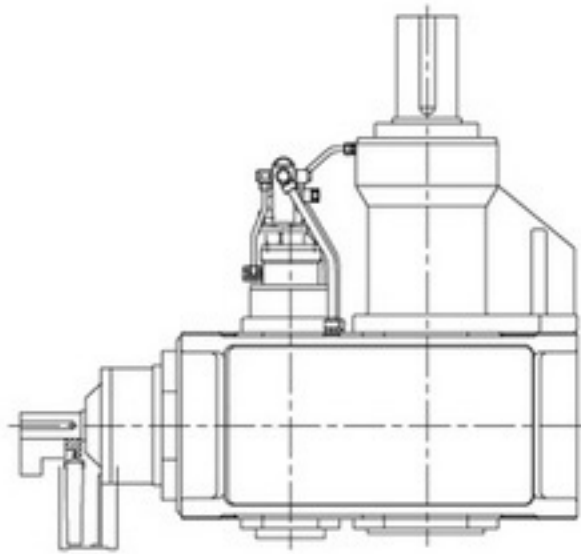

输出扭矩 Output torque: 3 ... 97.5 kNm
速比 Ratio: 5 ... 28
级数 Number of stages 2

7

造纸机械驱动齿轮箱 Paper machine drives
H系列斜齿齿轮箱和B系列螺旋锥齿轮-斜齿齿轮箱
Helical gear units bevel-helical gear units

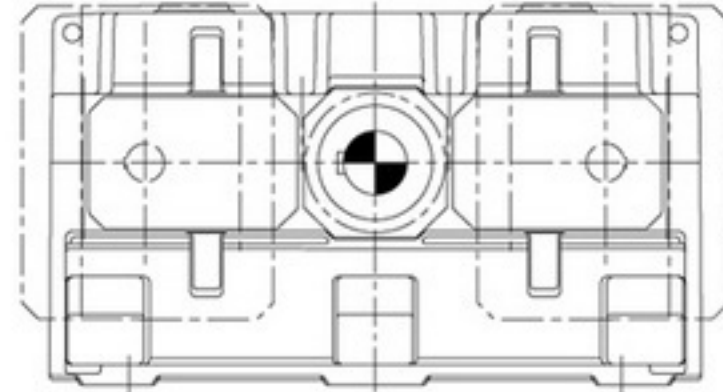

输出扭矩 Output torque: 0.62 ... 820 kNm
速比 Ratio: 1.25 ... 22.4
级数 Number of stages 1, 2 or 3

8

搅拌机驱动用齿轮箱 Agitator Drives
H系列斜齿齿轮箱 Helical gear units

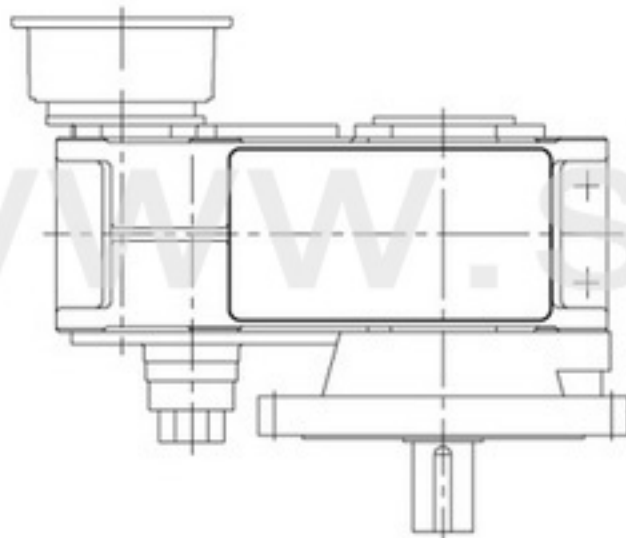

输出扭矩 Output torque: 10.2 ... 240 kNm
速比 Ratio: 6.3 ... 450
级数 Number of stages 2, 3 or 4

9

曝气机用驱动齿轮箱 Aerator drives
H系列斜齿齿轮箱和B系列螺旋锥齿轮-斜齿齿轮箱
Helical gear units and bevel-helical gear units

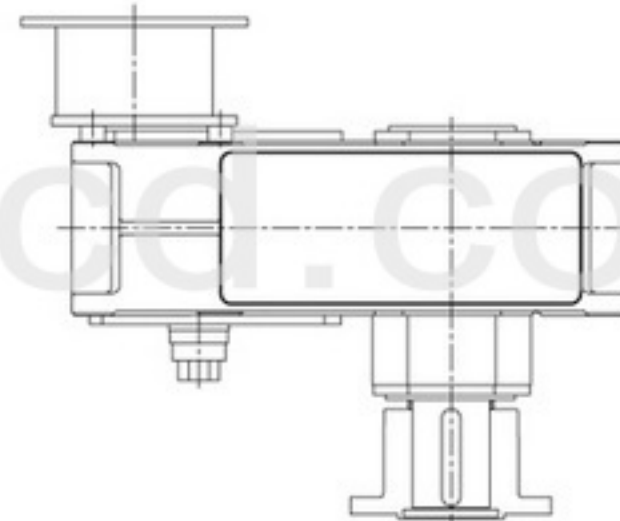

输出扭矩 Output torque: 9.4 ... 173 kNm
速比 Ratio: 6.3 ... 112
级数 Number of stages 2 or 3

10

分流式齿轮箱 Load sharing
H系列斜齿齿轮箱 Helical gear units

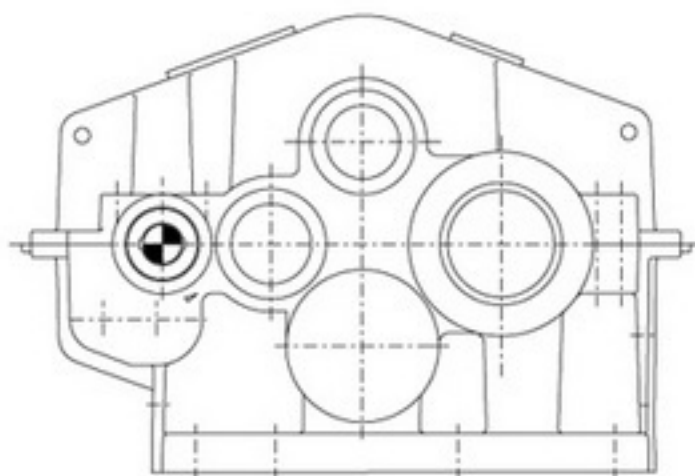

输出扭矩 Output torque: 550 ... 4800 kNm
速比 Ratio: 18 ... 900
级数 Number of stages 3, 4 or 5

11

挤压机用驱动齿轮箱 Extruders drives
H系列斜齿齿轮箱 Helical gear units

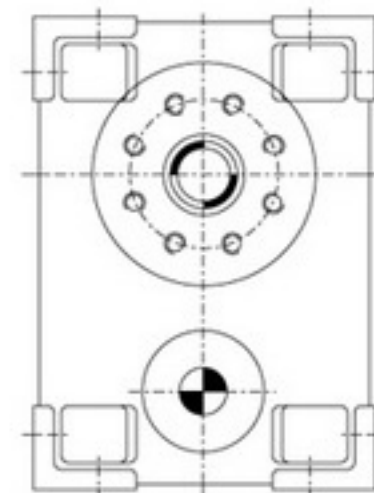

输出扭矩 Output torque: 0.3 ... 2300 kNm
速比 Ratio: 3 ... > 500
级数 Number of stages 2,3 or 4

12

详细资料请来电咨询。

Please consult us for detailed materials.

附1 行走机构

Travelling Gear Drives

根据需要的附加变型产品资料

Additional Variants Information on Request

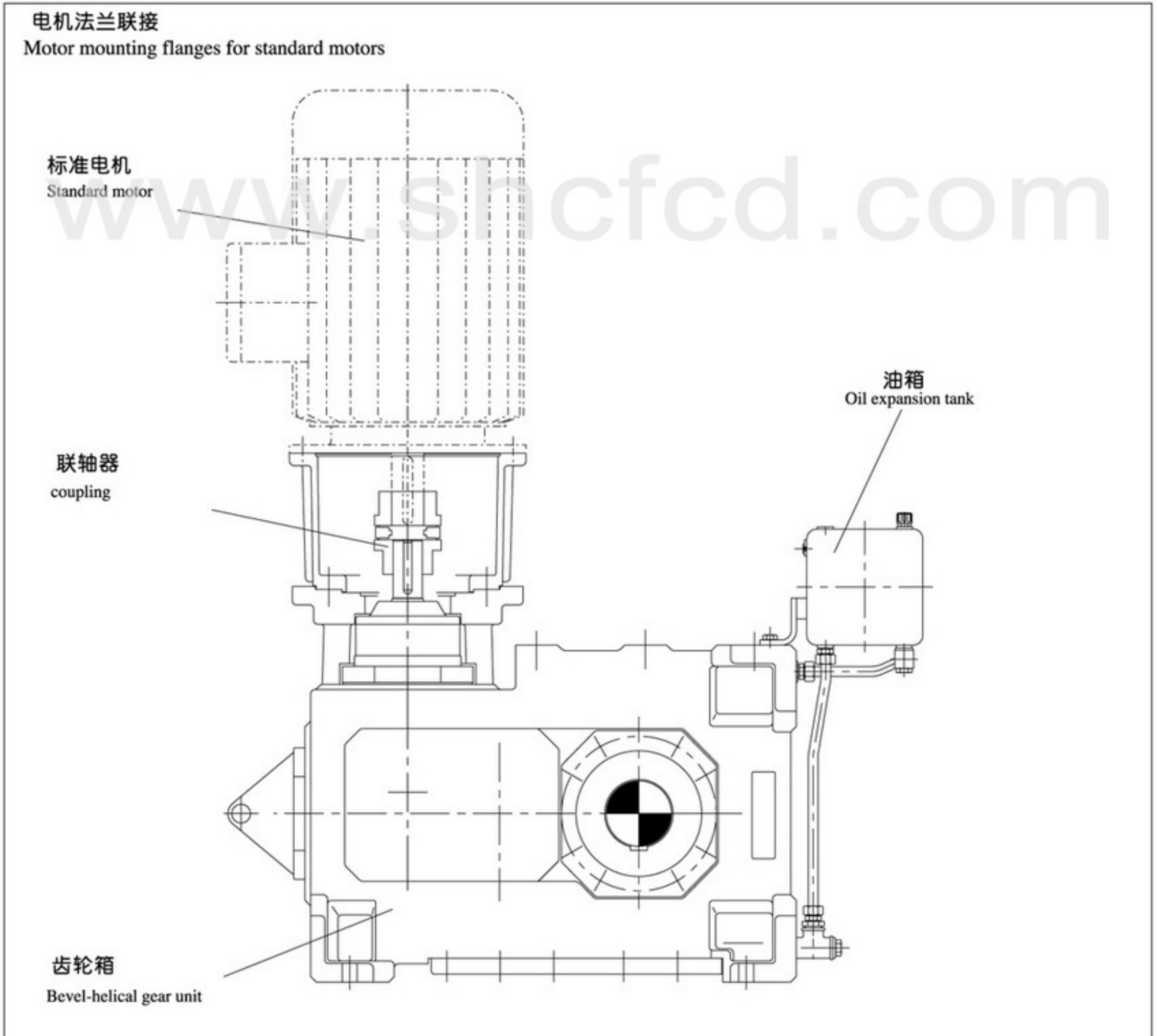
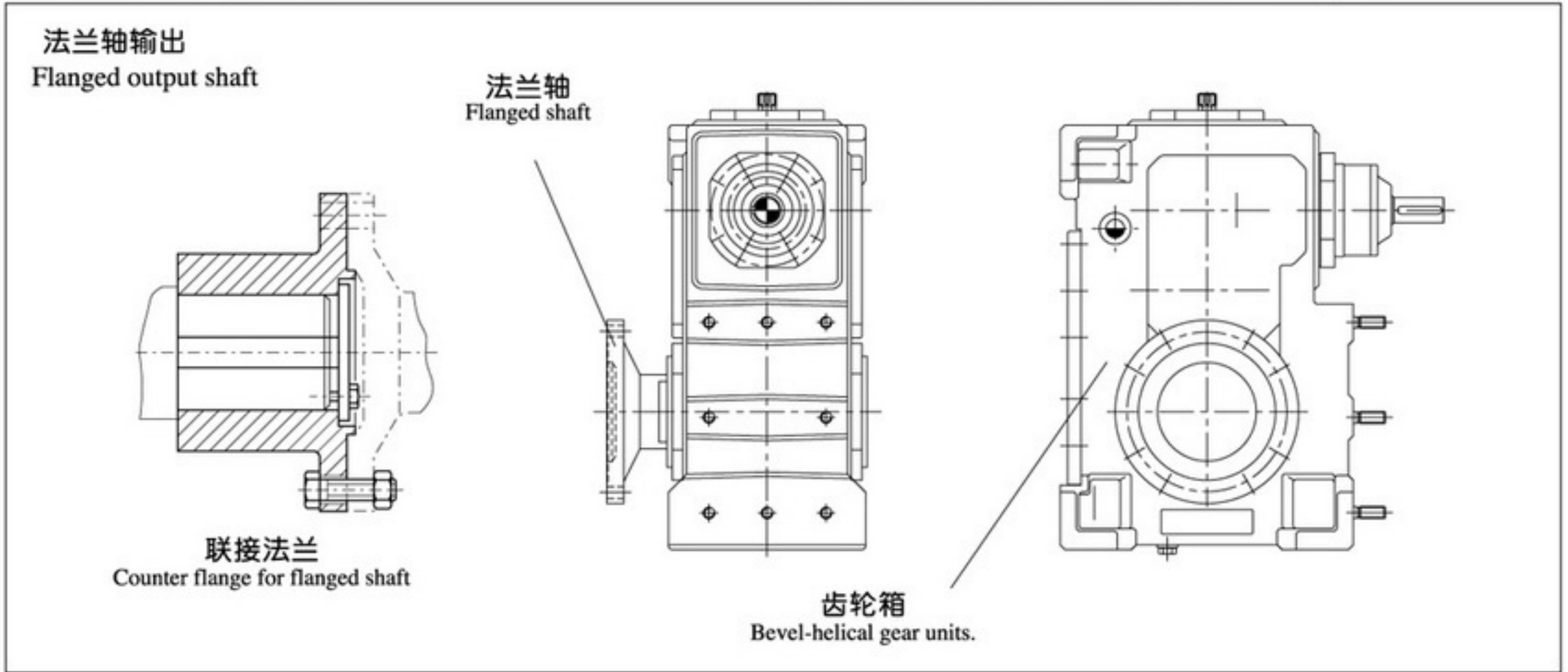

附2 输送机

Conveyor drives

根据需要的附加变型产品资料

Additional Variants Information on Request

钟形罩式法兰联接
Motor bell housings for standard motors

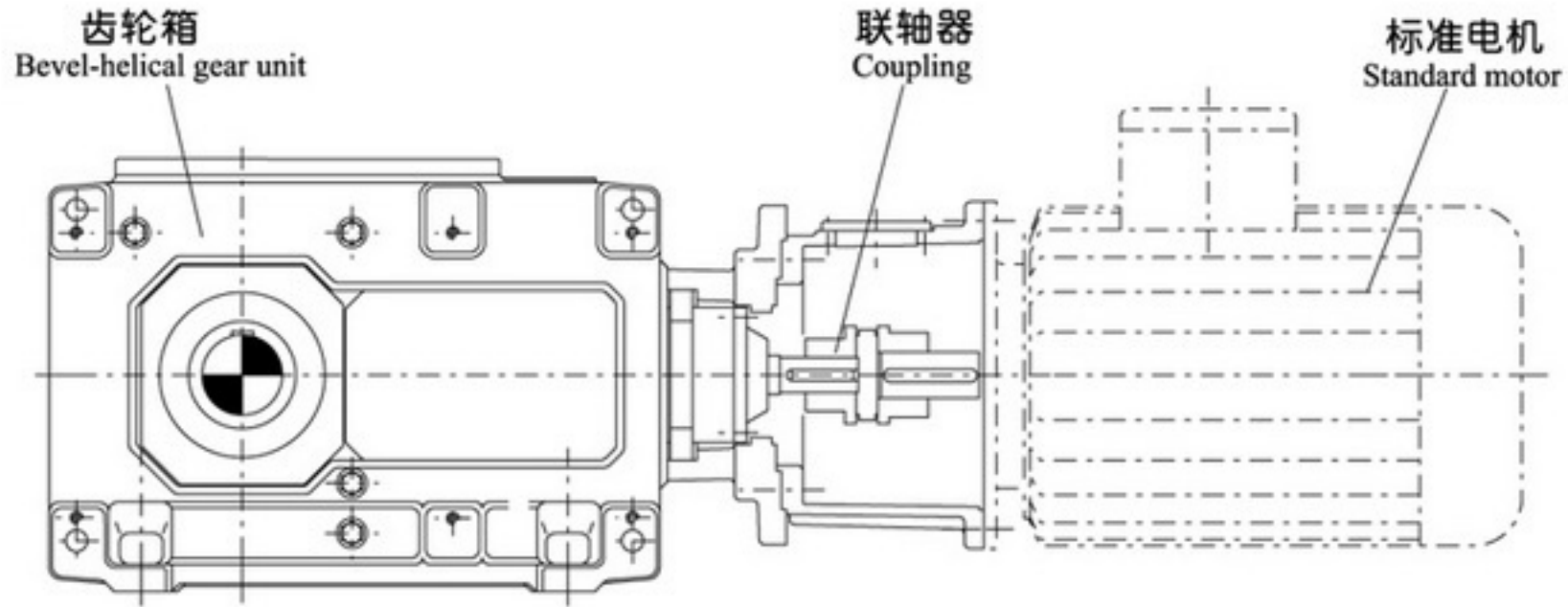

扭力臂式安装
Torque supports for gear housings

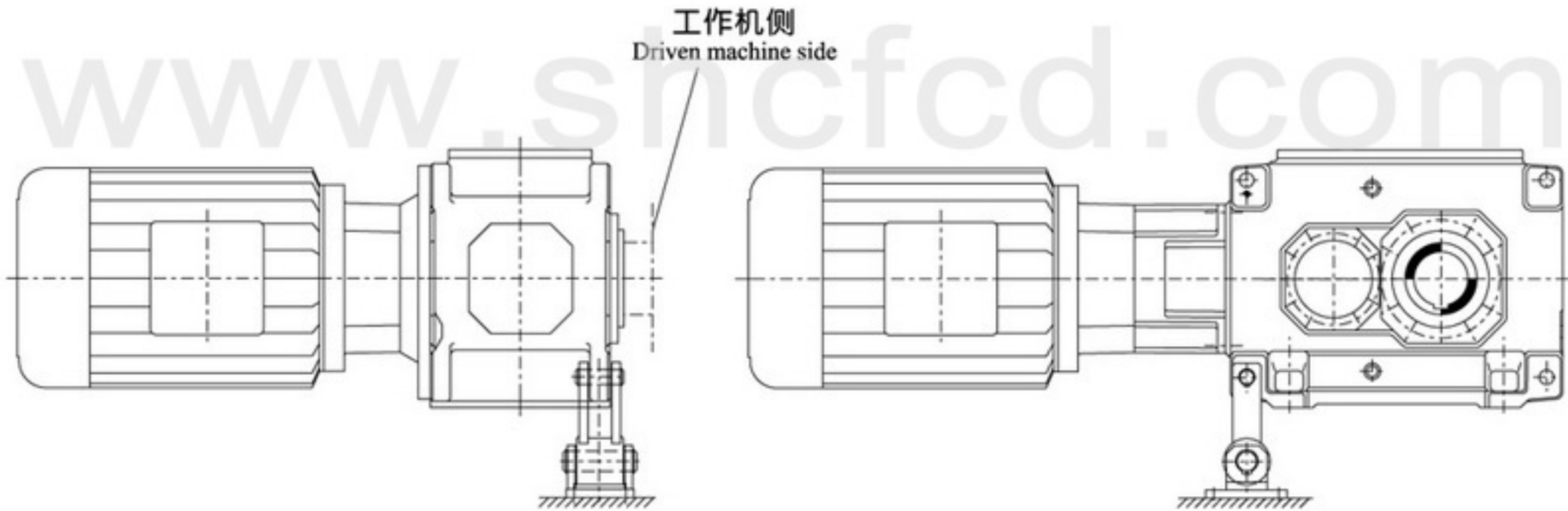

扭力臂应在靠工作机一侧，如果减速机带有风扇，扭力臂就安装在电扇另侧。
Torque support on driven machine side. If the gear unit has a fan, the torque support has to be located opposite the fan.

扭力臂
Torque supports

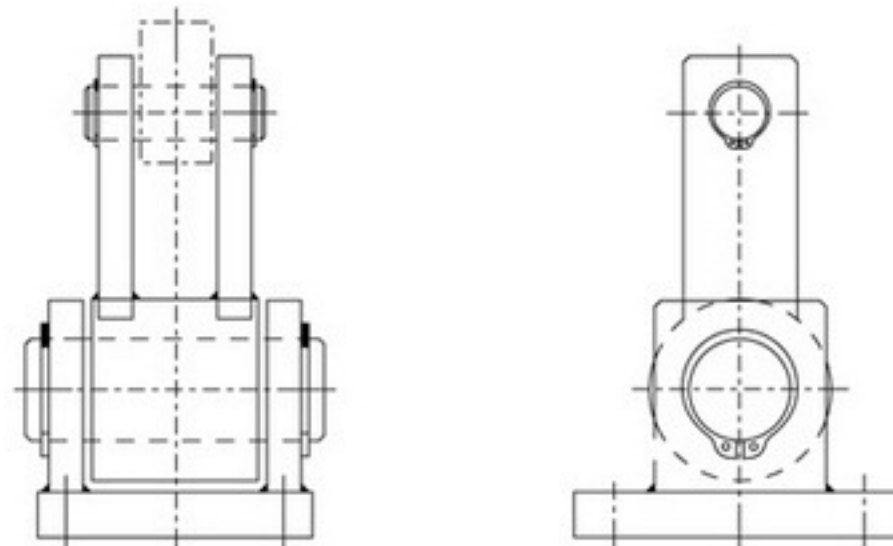

附3 输送机

Conveyor drives

根据需要的附加变型产品资料

Additional Variants Information on Request

带齿轮箱摆动底座
Gear unit swing-bases

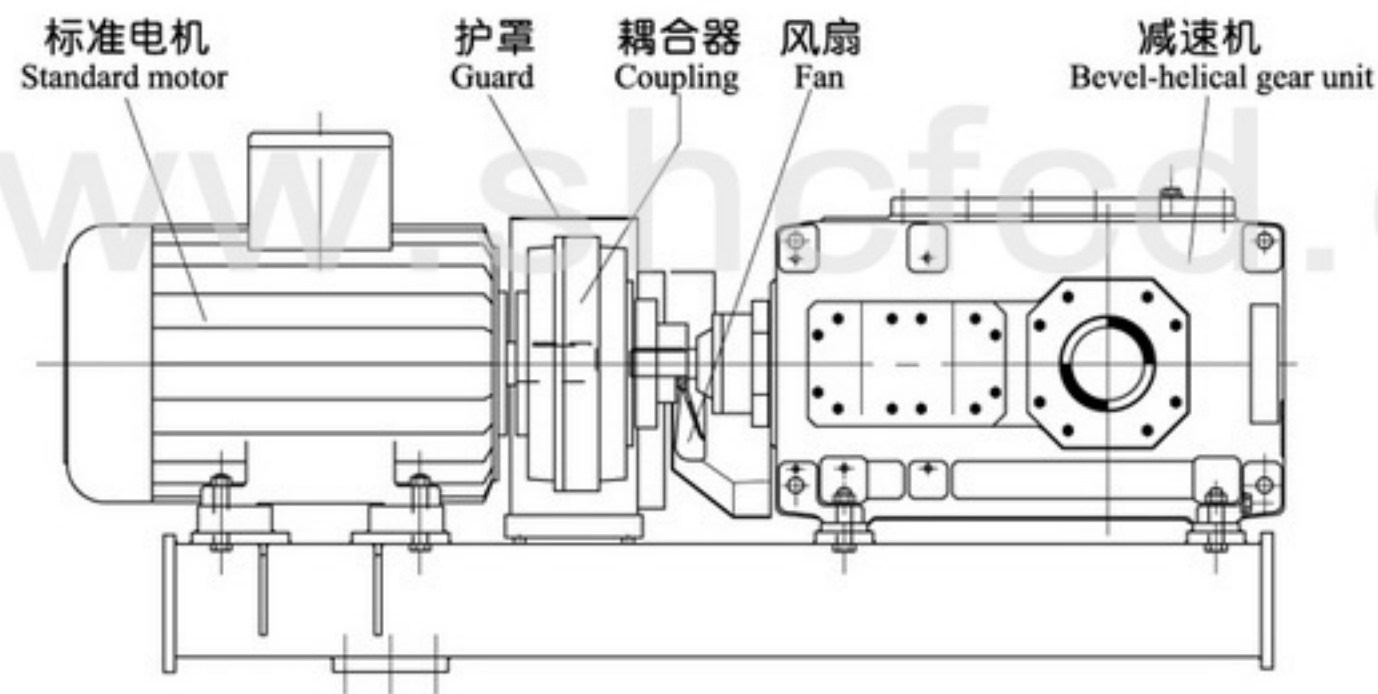
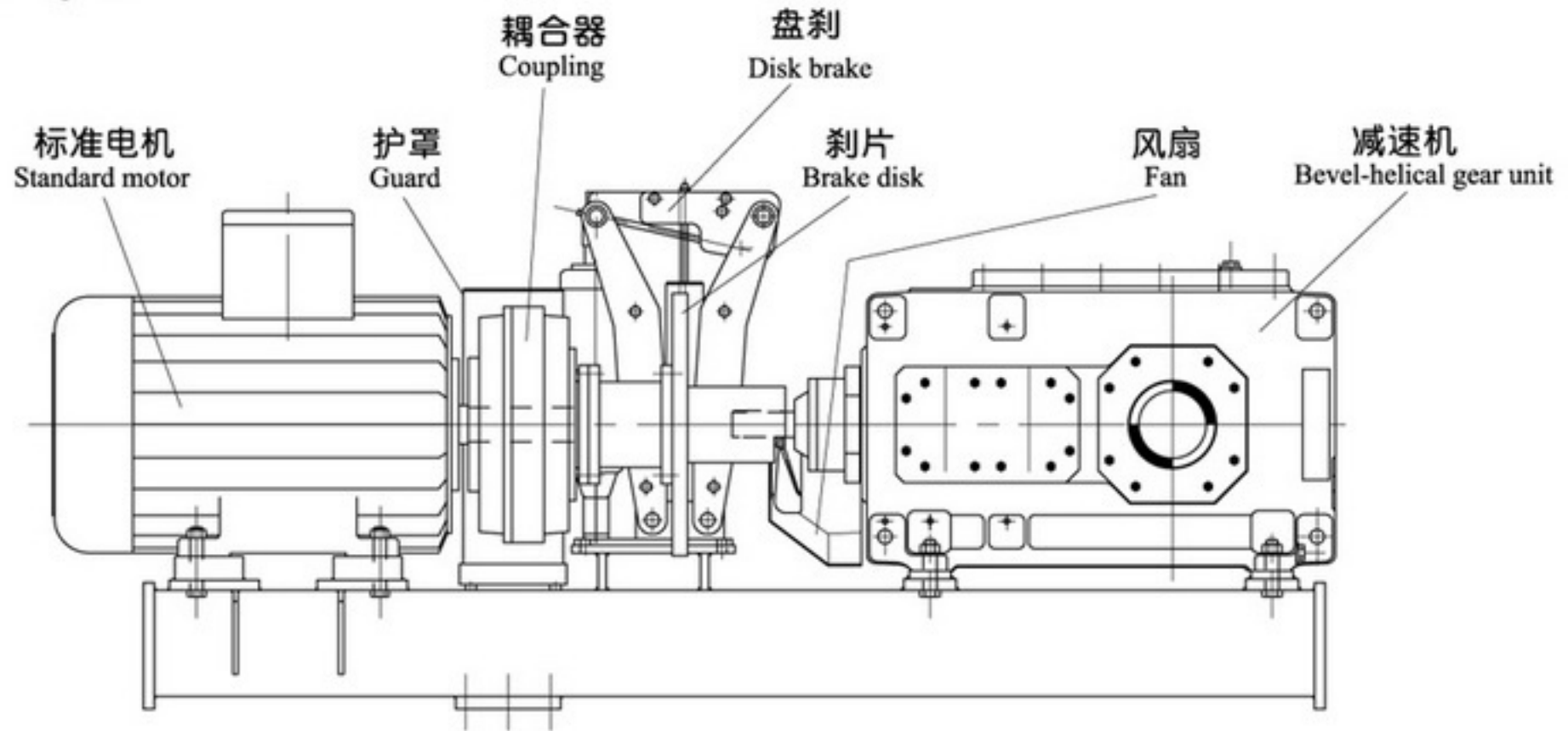

齿轮箱摇摆支点支座
Supports for gear unit swing-bases

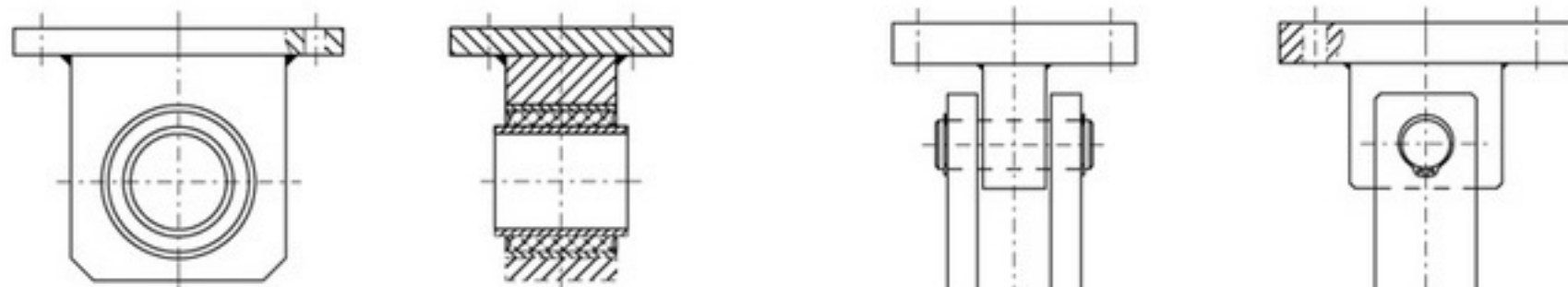

活动支座
Flexible pedestal

力臂支架
Torque supports